



**HAL**  
open science

# Visual learning in *Apis mellifera* under virtual reality conditions

Gregory Lafon

► **To cite this version:**

Gregory Lafon. Visual learning in *Apis mellifera* under virtual reality conditions. Neuroscience. Université Paul Sabatier - Toulouse III, 2022. English. ⟨NNT : 2022TOU30016⟩. ⟨tel-03714699⟩

**HAL Id: tel-03714699**

**<https://theses.hal.science/tel-03714699v1>**

Submitted on 5 Jul 2022

**HAL** is a multi-disciplinary open access archive for the deposit and dissemination of scientific research documents, whether they are published or not. The documents may come from teaching and research institutions in France or abroad, or from public or private research centers.

L'archive ouverte pluridisciplinaire **HAL**, est destinée au dépôt et à la diffusion de documents scientifiques de niveau recherche, publiés ou non, émanant des établissements d'enseignement et de recherche français ou étrangers, des laboratoires publics ou privés.



HAL Authorization



# THÈSE

En vue de l'obtention du  
**DOCTORAT DE L'UNIVERSITÉ DE TOULOUSE**  
Délivré par l'Université Toulouse 3 - Paul Sabatier

---

Présentée et soutenue par  
**Grégory LAFON**

Le 25 mars 2022

**Apprentissage visuel en réalité virtuelle chez Apis mellifera**

---

Ecole doctorale : **BSB - Biologie, Santé, Biotechnologies**

Spécialité : **NEUROSCIENCES**

Unité de recherche :

**CRCA - Centre de Recherches sur la Cognition Animale**

Thèse dirigée par

**Martin GIURFA et Aurore AVARGUES-WEBER**

Jury

**M. Ludovic Dickel**, Rapporteur

**Mme Elisa Frasnelli**, Rapporteur

**M. Stéphane Viollet**, Rapporteur

**M. Martin GIURFA**, Directeur de thèse

**Mme Aurore Avargues-Weber**, Co-directrice de thèse

## 1 Table of Contents

2	Acknowledgements.....	3
3	List of abbreviations.....	5
4	Aims and goals.....	6
5	General Introduction.....	8
6	Prior studies on honey bee visual learning.....	10
7	Experiments with free-flying bees.....	11
8	Experiments with free-walking bees.....	18
9	Visual learning under full immobilization: conditioning of appetitive and aversive reflexes....	23
10	Virtual Reality: an innovative approach to study visual learning in bees.....	29
11	Studying navigation and attentional processes.....	30
12	Studying associative learning and memory.....	35
13	Benefits and caveats of using virtual reality to study visual learning in bees.....	40
14	What do we know of the underlying mechanism of visual learning?.....	43
15	The Optic lobes.....	44
16	The ventrolateral neuropils.....	46
17	The central complex.....	48
18	The mushroom bodies.....	50
19	Whole circuit mechanisms.....	54
20	References.....	59
21	Chapter 1: Motion cues from the background influence associative color learning of honey bees	
22	in a virtual-reality scenario.....	68
23	Preface.....	69
24	Summary.....	71
25	Introduction.....	72
26	Materials and methods.....	74
27	Results.....	84
28	Discussion.....	99
29	References.....	108
30	Chapter 2: Visual learning in a virtual reality environment upregulates immediate early gene	
31	expression in the mushroom bodies of honey bees.....	112
32	Preface.....	113
33	Summary.....	115

34	Introduction.....	116
35	Results.....	118
36	Discussion.....	129
37	Methods.....	136
38	References.....	144
39	Chapter 3: The neural signature of visual learning under restrictive virtual-reality	
40	conditions.....	149
41	Preface.....	150
42	Summary.....	152
43	Introduction.....	153
44	Results.....	155
45	Discussion.....	165
46	Materials and Methods.....	172
47	References.....	180
48	Chapter 4: Comparison of associative visual learning in a 3D virtual reality between	
49	bumblebees and honeybees.....	187
50	Preface.....	188
51	Introduction.....	190
52	Materials and Methods .....	182
53	Results.....	201
54	Discussion.....	220
55	Conclusion.....	223
56	References.....	225
57	General Discussion.....	230
58	Virtual reality: progress, limitations and future developments.....	231
59	Investigating the brain regions involved in differential visual learning in VR.....	234
60	Bumblebees suitability for VR experiments.....	240
61	Conclusion.....	243
62	References.....	244
63		

## 64 Acknowledgements

65 This PhD thesis was made possible by the continuous support of many people.

66 I would like first to thank Aurore Avarguès-Weber and Martin Giurfa for supervising my PhD  
67 and for their thorough revision of the various articles produced in this project.

68 I also thank sincerely Dr. Ludovic Dickel, Dr. Elisa Frasnelli and Dr. Stephane Viollet for  
69 accepting to be part of my PhD jury and evaluate my work.

70 Thanks are also due to Dr. Jean-Christophe Sandoz and Dr. Ricarda Scheiner for accepting to  
71 be part of my thesis committee and for their helpful advice and guidance during my PhD.

72 I'm extremely grateful to Haiyang Geng and Isabelle Massou who are responsible for all the  
73 cellular and molecular analysis that made chapter 2 and 3, and their associated publications,  
74 possible. They have done a staggering amount of work for this project and I consider myself  
75 lucky to have had the opportunity to work with them.

76 I am thankful to Alexis Buatois who established the initial VR setup for helping me get started  
77 with my PhD and for encouraging me to improve the VR.

78 I also wish to thank Dr. Mathieu Lihoreau for providing colonies, and material to help us get  
79 started on the bumblebee experiments.

80 I'd like to thank Stephane Kraus and Mathilde Lacombrade for teaching me how to take care  
81 of the bumblebees.

82 I am grateful to Benjamin Paffhausen and Marco Paoli for many fruitful discussions, not all of  
83 them about our research. Their kindness and enthusiasm for science made working on this  
84 project truly enjoyable.

85 I would also like to thank Maud Combe and Patrick Arrufat for providing the technical support  
86 that I needed to develop both the hardware and the software used in this thesis.

87 I am also thankful to Dr. Gabriella de Brito Sanchez for sharing her insights on bee gustation.

88 Thanks also to all the intern that I had the chance to supervise: Rodrigue Fouillet, Juliette  
89 Montet, Diane Sam Mine, Emma Giordanengo, Catherine Macri, Clemence Guinement, Marin  
90 Nicolas, Naïs Judan, Eva Blot, and Karolina Pecharova. They have done an extensive amount  
91 of work for this project and I hope that their time with us was as beneficial to them as it was for  
92 me.

93 I am extremely gratefull to Dr Christian Jost for accepting to be my tutor in the DCCE program  
94 and helping me throughout my three years as a teaching assistant.

95 I am also gratefull to Dr. Jean-Marc Devaud, Dr. Cédrick Florian, Dr. Guillaume Isabel and Dr  
96 Christian Jost for giving me the opportunity to teach in their courses.

97 Finally, I am extremely grateful to my fellow PhD students for answering all my numerous  
98 questions about everything, from university paperwork to plant phylogeny, for helping me pick  
99 the color of my graphs and of course for many memorable nights out.

100

101 [List of abbreviations:](#)

102

103 AL: Antennal Lobe

104 AOTu: Anterior Optic Tubercle

105 APIS: Automatic Performance Index System

106 APL: Anterior Paired Lateral

107 CB: Central Brain

108 CS: Conditioned Stimulus

109 CX: Central Complex

110 DA: Dopamine

111 FB: Fan-shaped Body

112 GABA: Gamma-Aminobutyric Acid

113 GLMM: generalized Linear Model

114 IEG: Immediate Early Gene

115 LMC: Laminar Monopolar Cell

116 LMM: Linear Mixed Modal

117 LTM: Long Term Memory

118 MB: Mushroom Body

119 NC: No Choice

120 OA: Octopamine

121 OL: Optic Lobe

122 PB: Protocerebral Bridge

123 PER: Proboscis Extension Response

124 RNA: Ribonucleic Acid

125 RT-qPCR: Reverse Transcription Quantitative Polymerase Chain Reaction

126 SER: Sting Extension Response

127 sKC: Small Kenyon Cell

128 US: Unconditioned Stimulus

129 UV: Ultra Violet

130 VL: Vertical Lobe

131 VR: Virtual Reality

132

## 133 Aims and goals

134 The general objective of this doctoral thesis is to explore the underlying mechanism of visual  
135 learning in the honeybee *Apis mellifera*. To do so we decided to use virtual reality (VR), in  
136 order to move from the classical studies using free-fly flying bees to a controlled setup in which  
137 a tethered animal would learn visual discriminations. Our team had recently developed a new  
138 VR setup, which was far from being immersive as it allowed only translational stimuli  
139 movements (i.e. 2D VR). In order to be able to use VR to its full potential we first worked on  
140 upgrading the existing setup to a true 3D virtual environment. This introduced the possibility  
141 of enriching the VR with a background that could generated optic flow as the bee moves within  
142 the virtual world.

143 This new possibility inspired the first question addressed in this work, namely *how do motion*  
144 *cues from the background influence associative color learning in bees in the 3D VR*  
145 *environment?* To answer this question, we used our new setup to test if and how frontal motion  
146 cues generated in the VR and ventral motion cues generated by the movement of the treadmill  
147 below the bee affected color discrimination learning. In the first chapter, we present the answer  
148 to this question and identify issues that may affect decision-making in VR landscapes.

149 Answering that first question led us to refine both our setup and our conditioning protocols,  
150 thus raising our second question: *What are the brain regions involved in visual learning?* To  
151 answer it, we quantified expression of three Immediate Early Genes (IEGs) that serve as  
152 markers of neural activity in brain areas and that had been related to bee foraging and  
153 orientation: *kakusei*, *Hr38* and *Erg1*. We analyzed the expression of these IEGs in the calyces  
154 of the mushroom bodies, the optic lobes and the rest of the brain after color discrimination  
155 learning in VR. More specifically, we asked if the nature of IEG expression, and thus the areas  
156 involved in visual learning, change depending on the way in which the animal learns the visual

157 discrimination. We thus compared IEG expression after learning in the 3D environment and  
158 after learning in the 2D environment which set more constraints in terms of stimulus  
159 movements. These two analyses are presented in two separate chapters

160 The study of the neural mechanisms underlying visual learning requires using invasive  
161 approaches to access the brain of the insects, which induces stress and can thus impair  
162 behaviors. To potentially mitigate this effect, we performed an additional study using  
163 bumblebees *Bombus terrestris*, which could constitute a good alternative to *Apis mellifera* as  
164 they are bigger and more robust and resistant to potentially harming procedures. In the last  
165 chapter, we explored the performance of bumblebees in a differential learning task in the VR  
166 and compared it to that of honeybees.

167 Overall, our work resulted in a novel and robust 3D VR system that is inexpensive, open source  
168 and supports experiments on both bumblebees and honeybees. This system represents therefore  
169 a qualitative advance for studies on honey bee visual learning. We also produced the first  
170 quantification of IEG expression in the bee brain as a result of associative visual learning and  
171 provide data showing the implication of mushroom bodies in this learning form. Taken together  
172 our results open the way for a deeper exploration of the mechanisms of visual learning through  
173 VR experimentation.

174

## 175 Introduction

176 Honeybees are flying hymenoptera famous for their social organization and their important  
177 contribution to the pollination of crops and wild plants. Honeybees are central place foragers  
178 that are flower constant (Grant, 1951; Chittka et al., 1999), meaning that they tend to constantly  
179 return to the same species of flower as long as they are available and profitable, even if other  
180 more rewarding flower species are available in the vicinity. In relation with both their  
181 eusociality and their status as central place foragers, honeybees have developed a complex  
182 system of communication relying on one hand on pheromones and on the other hand on  
183 stereotyped movements called “dances”, which vary in shape according to the range of  
184 distances separating the hive and the food source (Frisch et al., 1967). The most studied dance  
185 type is the waggle dance, which reports distance and direction of profitable food source to nest  
186 mates. It’s the discovery of this surprising behavior that made ethologist Karl von Frisch famous  
187 (Frisch et al., 1967) and might have played an important role in consolidating the honeybee,  
188 among a few other invertebrates, has a major research model in neuroscience and behavior.

189 Given honeybees’ flower constancy, they have the capacity to learn and memorize the essential  
190 traits that characterize the flower species they exploit at a time. Honeybees ability to identify  
191 and remember particular flowers species through numerous foraging bouts for periods of time  
192 that can span several days make them a very enticing species for studying learning and memory  
193 (Menzel, 1999). Even more so because their brain is made of about 950 000 neurons for a  
194 volume of about 1 mm<sup>3</sup>, which makes the underlying mechanism of their cognitive abilities  
195 more accessible. Hence, for more than fifty years now, honeybees’ associative learning abilities  
196 have been extensively studied (Giurfa, 2007). Studies on honeybee learning have spanned  
197 mostly the visual and the olfactory domain but have reached a unique dimension in the latter  
198 given the fact that honeybees can be easily conditioned to respond appetitively to a particular  
199 odorant while being immobilized (Takeda, 1961; Bitterman et al., 1983; Giurfa and Sandoz,

200 2012). For the conditioning of the Proboscis Extension Response (PER) (Felsenberg et al.,  
201 2011) each bee is restrained in an individual harness such that it can only freely move its  
202 antennae and mouth-parts (mandibles and proboscis). When the antennae of a bee are touched  
203 with sucrose solution, the animal exhibits the PER, i.e. it reflexively extends its proboscis to  
204 reach out to the sucrose. Neutral odorants blown to the antennae do not release such a reflex in  
205 naive animals. If, however, an odorant is presented immediately before sucrose solution  
206 (forward pairing), an association is formed which enables the odorant to elicit the PER in a  
207 following test. This effect is clearly associative and constitutes a case of classical conditioning  
208 (Bitterman et al., 1983), i.e. the odorant can be viewed as the conditioned stimulus (CS) and the  
209 sucrose solution as the rewarding, unconditioned stimulus (US) (Fig.5). Within this framework,  
210 bees learn to associate the odorant with the sucrose reward. Immobilization is crucial in this  
211 context as it enabled the use of multiple invasive techniques to study the cellular and molecular  
212 underpinnings of olfactory learning and memory (Mauelshagen, 1993; Abel et al., 2001;  
213 Komischke et al., 2005; Boitard et al., 2015; Carcaud et al., 2016).

214 Studies on olfactory learning have been mostly confined to the use of elemental protocols, that  
215 rely on the simple unambiguous association of at least two elements like in PER conditioning,  
216 although more recently, studies on non-elemental olfactory learning, protocol in which the  
217 reward or its absence is not associated univocally with the stimulus, have also revealed a  
218 capacity to solve non-linear discriminations, i.e. to go beyond simple forms of associative  
219 learning (Meyer and Galizia, 2012; Devaud et al., 2015a). Yet, at the same time as it offered  
220 the advantage of neural and molecular access, immobility represented a significant burden for  
221 the possibility of observing the richness and cognitive complexity of free behavior. Experiments  
222 with freely flying bees trained to solve discriminations in the visual modality showed precisely  
223 that the cognitive capacities of bees under these experimental conditions were highly elaborated  
224 and parallel to some abilities that were thought a prerogative of vertebrates (Avarguès-Weber

225 et al., 2011a; Avarguès-Weber and Giurfa, 2013). For instance, free-flying honeybees were  
226 shown to be able to learn concepts, a relation between different objects that is independent of  
227 the physical nature of the objects linked by the relation (Lamberts et al., 1998; Zentall et al.,  
228 2002; Doumas et al., 2008; Zentall et al., 2008; Halford et al., 2010), in the visual modality  
229 such as sameness (Giurfa et al., 2001) or above/below (Avarguès-Weber et al., 2011b) and  
230 even combinations of those concepts (Avarguès-Weber et al., 2012a). However, the exploration  
231 of the underlying mechanisms of visual learning, be it simple associations or conceptual  
232 learning, has remained elusive due to the impossibility of accessing the nervous system of flying  
233 bees solving visual problems. At the same time, conditioning harnessed bees to visual stimuli  
234 has yielded low rates of success (Avarguès-Weber and Mota, 2016). A goal of this thesis  
235 consisted, therefore, in overcoming this historic limitation by establishing a new experimental  
236 paradigm allowing the coupled study of visual learning and neural analyses in bees.

### 237 [Prior studies on honeybee visual learning](#)

238 Honeybee visual learning has been studied for more than a century now, and many different  
239 techniques and setups have been developed to this end. In order to understand what needs to be  
240 done to allow us to progress in our understanding of their visual learning abilities we first need  
241 to know what has already been done, what worked, and what didn't. In this part, I will show  
242 that looking at the hundred years of scientific development (starting with von Frisch's seminal  
243 demonstration of color vision in free-flying bees) clearly outlines the great success of  
244 experiments on freely moving bees, which contrasts with the milder results obtained so far with  
245 immobilized bees.

### 246 [Experiments with free-flying bees](#)

247 In his pioneering work on honeybee vision, Karl von Frisch aimed at demonstrating that  
248 honeybees were endowed with color vision, although at that time the status quo was to claim  
249 that they were color blind (Hess, 1911). To this end, he trained bees to freely fly to an

250 experimental set up where they could get sucrose solution in a small Petri dish placed on a blue  
251 piece of cardboard; then he tested the bees returning to the experimental site by offering at the  
252 same location several targets, one blue, the same used during training, and various shades of  
253 grey (Von Frisch, 1914). On all these visual stimuli, an empty Petri dish was presented. The  
254 rationale of this experiment was to show that bees would not confound the learned color hue  
255 with an achromatic intensity (a shade of grey) that would be common to the blue and grey  
256 cardboards (Fig.1). He showed indeed that the majority of the bees chose to go to the blue target  
257 and not to the achromatic alternative displaying a similar intensity (Von Frisch, 1914). With  
258 this experiment, which he repeated for various color hues, he demonstrated unequivocally that  
259 honeybees are able to perceive colors.

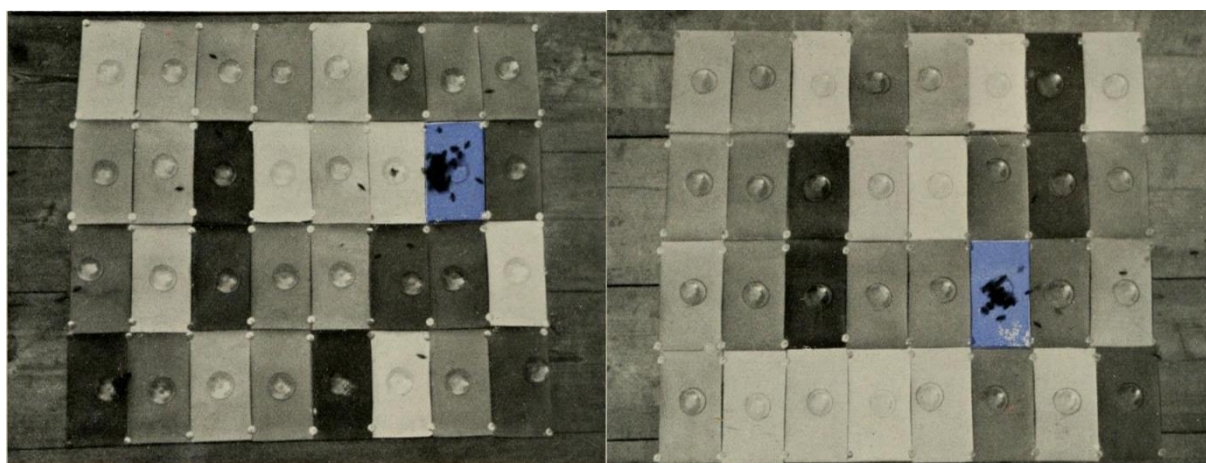

260

261 **Figure 1. Color vision of the honeybees.** Experimental results from von Frisch experiment.  
262 Bees were trained to feed on blue feeders and were tested on a multitude of feeders in random  
263 arrangement of blue and grey stimuli. The blue feeder received more visits than the achromatic  
264 ones. Taken from von Frisch 1914.

265 Since then, many experiments have studied different form of visual learning in free-flight  
266 conditions. In this type of experiment, trained honeybee foragers come directly from the hive  
267 to an experimental site where the stimuli to be learned and/or discriminated are offered, paired  
268 or not with a sucrose reward. The trained bee, marked with a color on its abdomen or thorax in  
269 order to identify it, will perform many flights between the hive and the experimental site to  
270 collect the food reward and thereby to answer the questions raised by the experimenter. This

271 scenario can be labeled as mainly operant conditioning (Rapaport, 1973) as obtaining or not the  
272 reward depends on the bees' actions because it is the decision of the bee to land or not on a  
273 given target that defines if the reward is obtained or not. Yet, it also includes Pavlovian  
274 associations between the visual stimulus and the reward (or absence of it) following the classic  
275 scheme of a CS-US association, and eventually associations between the visual stimulus and  
276 the response to be produced.

277 In 1967, Randolph Menzel initiated the study of color memory using free flying experiments  
278 (Menzel, 1967). In these experiments, bees were trained to collect sucrose solution on a  
279 horizontal table in which spectral filters illuminated from below provided the color cues to be  
280 learned. Bees were trained with one or more learning trials and varying alternative color (non-  
281 rewarded) presented adjacent to the rewarded color. The goal was to quantify the color memory  
282 resulting from this training for each wavelength trained. Memory retention was tested in  
283 extinction conditions (no reward provided) and presenting the rewarded color against a different  
284 color to assess the specificity of the color memory acquired. He demonstrated that bees are able  
285 to specifically learn the rewarded color and that different spectral colors are learned at different  
286 speeds. With violet (413, 428 nm) being the fastest and the most reliably learned with up to  
287 85% correct responses during the test, and blue-green (494 nm) being the slowest.

288 Presenting stimuli horizontally constituted a problem for the study of shape and pattern learning  
289 as bees could have only a partial view of a pattern perceived upon their approach. It was  
290 therefore decided that presenting the stimuli vertically and frontally would preclude this  
291 problem as bees would be forced to see the trained stimuli entirely (Wehner, 1967). Since then  
292 the study of visual learning in freely flying bees switched to a vertical form of stimulus  
293 presentation in the majority of the works that aimed at controlling visual perception properly.  
294 Yet, another problem was realized later: what the bee would perceived depended on its distance

295 to the target, i.e. on the visual angle subtended by the stimulus, which determined or not that  
296 the stimulus was resolvable for the bees' visual system (Srinivasan and Lehrer, 1988).

297 A way to solve this problem was found by adopting Y-mazes, in which not only stimuli were  
298 presented vertically on the back walls, but also which allowed controlling the distance from the  
299 stimuli to a decision chamber leading to both maze arms. In this way, the visual angle of the  
300 visual stimuli could be controlled (Srinivasan and Lehrer, 1988; Hateren et al., 1990; M. Giurfa  
301 et al., 1996). In these experiments, forager bees are first trained to collect a sucrose reward at  
302 the end of each of the two arms of an experimental Y-maze. Then, during each conditioning  
303 trial, individual bees have to choose between a rewarded and a non-rewarded arm,  
304 distinguishable by adequate cues situated at the end of each arm (Fig.2).

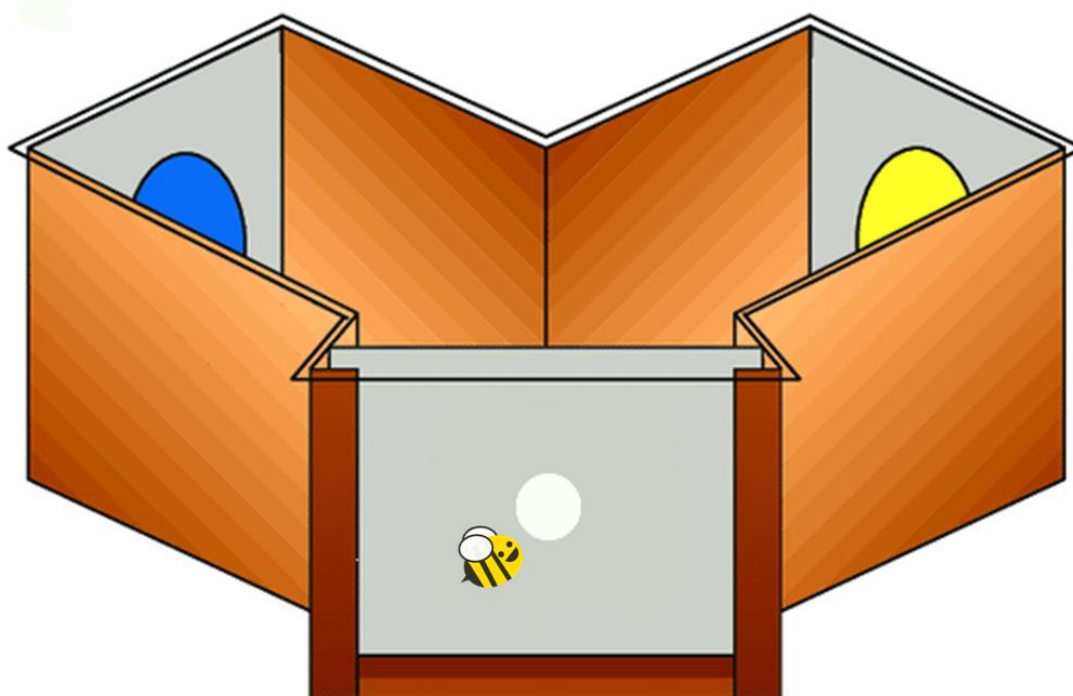

305

306 **Figure 2. Y-maze for honeybees.** Prior to this conditioning honeybees learn to come to the  
307 entrance of the maze by flying from their hive on their own accord to collect a sucrose reward  
308 from each arm of the maze. During each conditioning trial only one arm is rewarded in  
309 association with a particular stimulus the bee can see from the decision chamber and has to  
310 associate with the reward. Adapted from Avarguès-Weber et al., 2011a.

311 Using these various protocols allowed determining that bees can not only discriminate colors  
312 but also a large variety of visual attributes such as shapes and patterns, depth, motion, light  
313 intensity, contrast and complex configurations (Menzel, 1967; Zhang et al., 1996; Giurfa and  
314 Menzel, 1997; Horridge, 2000; Srinivasan, 2010; Avarguès-Weber et al., 2011a). Throughout  
315 the years free flight has been used extensively to analyze visual memory, discrimination and  
316 generalization (Zhang et al., 1992, 1999; Giurfa, 2004; Zhang et al., 2005; Dyer et al., 2011;  
317 Dyer, 2012; Zhang, 2012).

318 In the last two decades, however, a ‘cognitive revolution’ took place and visual learning moved  
319 to a different level, namely the study of higher order learning capacities in bees, capacities that  
320 until then were considered to be absent in the miniature brains of insects despite the fact that  
321 studies had already documented the ability of honeybees to generalize among visual stimuli  
322 (Horridge, 2009).

323 It started with the demonstration of symmetry categorization in bees (Martin Giurfa et al.,  
324 1996). Categorization consists in grouping together stimuli that are recognized as explicitly  
325 different but which are classified as similar based on shared attributes. Any unknown exotic  
326 bird will be recognized as a “bird” based on the presence of attributes defining this category  
327 such as wings, feathers, a beak, etc. In Giurfa et al. study bees were trained to collect a reward  
328 from vertically presented stimuli, as described earlier (Wehner, 1967), that remained constant  
329 only in their degree of symmetry. One group was trained to collect reward on symmetrical  
330 stimuli and the other on asymmetrical ones. During the test both groups were able to correctly  
331 chose the novel symmetrical or asymmetrical stimulus respectively. Bees were thus able  
332 perceive the bilateral symmetry and generalize it to novel stimuli.

333 Later, free flying bees were studied for their capacity to learn conceptual relationships, meaning  
334 concepts that rely on relationships between stimuli rather than on physical features of the stimuli  
335 (Zentall et al., 2002; Avarguès-Weber and Giurfa, 2013). One particular protocol possible to

336 test this capacity is the ‘delayed matching-to-sample’ task, in which an animal is presented with  
337 a ‘sample’ and subsequently with two or more secondary stimuli, one of which is identical to  
338 the sample. The animal is required to respond to the stimulus just encountered, i.e. to use the  
339 relational rule ‘choose the same as the same previously seen’, irrespective of the nature of this  
340 sample. The ‘delayed non-matching-to-sample’ is similar to the matching-to-sample task except  
341 that the animal is required to respond to the stimulus that is always different from the sample.  
342 In both cases, broadly construed sameness and difference concepts are shown only if the animal  
343 exhibits positive transfer to a completely new set of stimuli, which it had not experienced during  
344 training (Giurfa et al., 2001). This capacity was shown by Giurfa and collaborators, who trained  
345 honeybees, *A. mellifera*, in a delayed matching-to-sample paradigm to examine whether they  
346 could form a concept of sameness and a concept of difference (Giurfa et al., 2001). In the  
347 sameness version, each bee entered the maze by flying through a hole in the middle of an  
348 entrance wall. At the entrance, the bee encountered the sample stimulus. The sample was one  
349 of two different stimuli, A or B, alternated in a pseudo-random sequence. The entrance led to a  
350 decision chamber, where the bee could choose one of two arms. Each arm carried either  
351 stimulus A or stimulus B as secondary stimulus. The bee was rewarded with sucrose solution  
352 only if it chose the stimulus that was identical to the sample. If the bees managed to learn the  
353 original discrimination, they were tested with a new sample and secondary stimuli in ‘transfer  
354 tests’ in extinction conditions (no reward provided): the bees had to choose between stimuli C  
355 and D, when the sample was either C or D. In such tests, bees that had been trained to match  
356 colors could match achromatic gratings and bees that had been trained to match achromatic  
357 gratings could match the colors with a success rate of about 70%, demonstrating thereby the  
358 capacity to learn the concept of sameness. Similar experiments demonstrated also the capacity  
359 to learn the concept of difference. Further work demonstrated that bees can also handle concepts

360 such as above/below (Avarguès-Weber et al., 2011b), left/right and even process and learn both  
 361 difference and spatial relationships at the same time (Avarguès-Weber et al., 2012a).

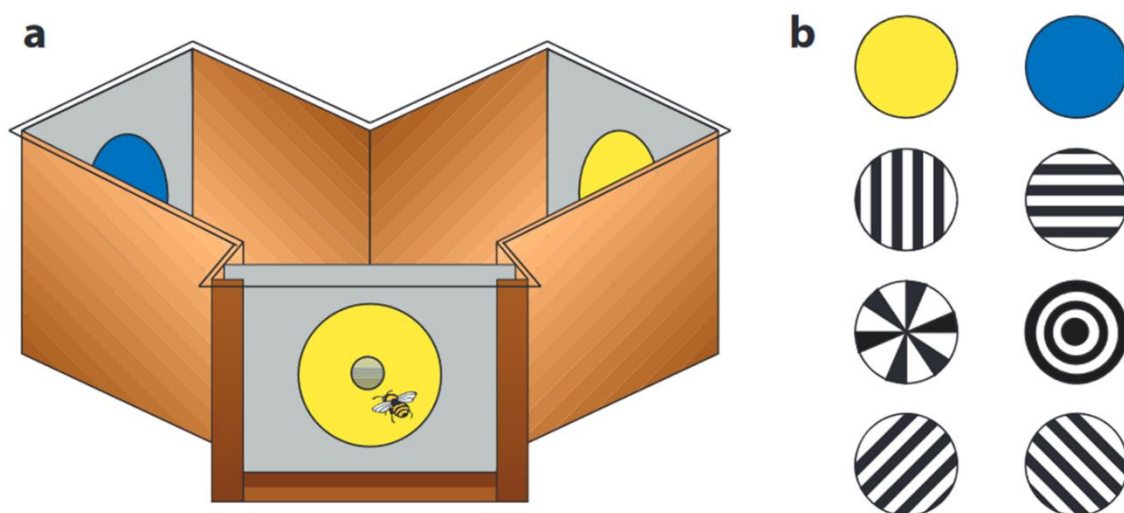

362

363 **Figure 3. Rule learning in honeybees.** (a) Honeybees trained in a delayed matching-to-sample  
 364 task to collect sugar solution in a Y-maze where they first get a sample at the entrance and then  
 365 a choice within the maze and need to choose the stimulus matching the initial sample. (b)  
 366 They are trained on a series of patterns or colors to learn a rule of sameness. Bees trained on the  
 367 patterns were tested on the colors and vice-versa. In both cases, bees chose the novel stimuli  
 368 corresponding to the sample. Taken from Avarguès-Weber et al., 2011a.

369 More recently the Y-maze was used to investigate numerical cognition in free-flying  
 370 honeybees. It was shown that bees are endowed with numeric competence and can count visual  
 371 items until 4 or 5, different results were obtained in different experiments (Chittka and Geiger,  
 372 1995; Dacke and Srinivasan, 2008; Gross et al., 2009; Skorupski et al., 2018). Bees could also  
 373 manage some basic level of addition and subtractions (Howard et al., 2019). In this study  
 374 honeybees were trained to enter a Y-maze and view a visual sample stimulus presented  
 375 vertically containing a set of elements of a given color. The color defined the arithmetic  
 376 operation to perform once in the maze. For instance, if three blue items were shown at the  
 377 entrance of the maze, the blue color indicated addition of one; therefore, the bee entering the  
 378 maze should choose a stimulus displaying four items and not two or five. If the items at the  
 379 entrance were yellow, the arithmetic operation to perform was subtraction of one. Thus, if three

380 yellow items were shown at the entrance, choice of two within the maze represented the correct  
381 option. The color of the elements, and thus the arithmetic problem to be solved, was randomly  
382 assigned per bee for each trial. Correct and incorrect options during experiments ranged from  
383 one to five elements, and the incorrect option could be higher or lower than the correct option  
384 (which also included the sample number as a possible incorrect option). The sample number of  
385 three elements was never shown during training and was only used as a novel sample number  
386 during testing.

387 Flying bees are able to perform very difficult tasks when flying through unknown environments  
388 relying mainly on the optic flow cues generated by their own motion (Horridge, 1987). Optic  
389 flow is the speed of movement of an image on the retina, it can be used as a proxy of distance  
390 as object that are close appear to be moving faster than object that are further away. In 1989  
391 Kirchner and Srinivasan trained bees to receive a food reward at the end of a tunnel where each  
392 wall displayed a pattern of vertical black bars and white gratings, to create a texture that would  
393 produce optic flow on the retina of the bees, one of the gratings could be moved either in the  
394 direction of the flight or against it, to reduce or increase the optic flow respectively (Kirchner  
395 and Srinivasan, 1989). They showed that bees flied in the middle of the tunnel when the optic  
396 flow was equivalent on both sides but when the grating was moved in the same direction as the  
397 bees' flight, thus reducing optic flow, bees flied closer to the moving grating. Respectively  
398 when optic flow was increased bees flied further away from the moving grating. They thus  
399 concluded that honeybees use optic flow as a measure of object distance and use this measure  
400 to avoid collisions during flights. Since then it was shown that optic flow is also used to control  
401 speed, height, and to avoid lateral obstacle (Srinivasan et al., 1991; Baird et al., 2006; Baird and  
402 Dacke, 2012; Baird et al., 2021). The impressive abilities of bees to fly through complex  
403 environment using optic flow to guide them has been reproduce in biomimetic robots that was  
404 shown to reproduce bees ability to avoid collision in narrow corridors and adjust their speed in

405 wind condition (Roubieu et al., 2014), thereby showing that managing optic flow is sufficient  
 406 to reproduce the honeybee flying abilities in flight corridors (Fig.3).

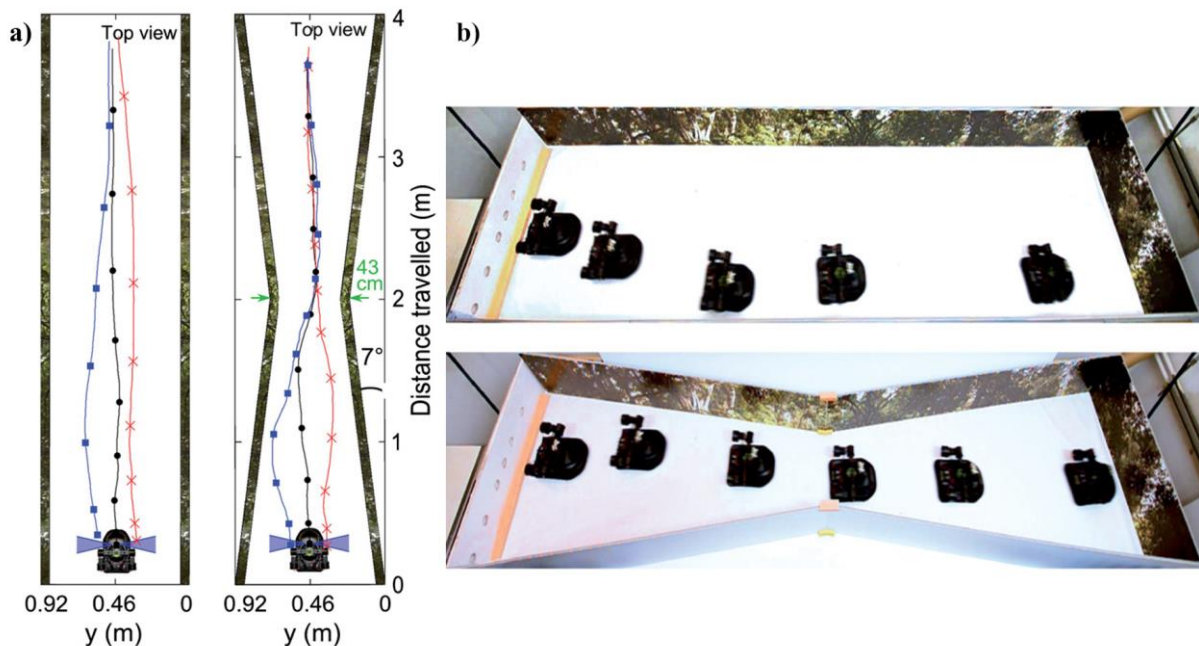

407

408 **Figure 3. Automatic speed control and lateral positioning of a miniature hovercraft**  
 409 **navigating in a 4 m long straight or tapered corridor (a).** The hovercraft is equipped with a  
 410 bee-inspired autopilot based on the dual optical flow regulators and is endowed with an insect-  
 411 inspired 4-pixel visual system. (b) Chronophotography (~1s time interval) of the hovercraft  
 412 crossing the corridor. Adapted from Roubieu et al., 2014.

413 Free flights experiments have proven to be a very powerful tool in the investigation of  
 414 honeybees' visual cognition and allowed to uncover the bee incredible learning abilities and  
 415 cement it as a major model organism in neuroscience. However, because free flight experiments  
 416 take place in the field they lack the finer control that lab experiments can allow and more  
 417 importantly, they preclude the use of invasive methods to study the mechanisms of these  
 418 intriguing performances.

#### 419 Experiments with free-walking bees

420 The visual learning of honeybees can also be studied in more controlled paradigms in which  
 421 bees walk, generally within reduced setups which force the animals to walk instead of flying.  
 422 For instance, Zhang et al (Zhang et al., 1998) trained bees to walk through a narrow tunnel

423 carrying visual stimuli on the two walls to study their capacity to learn routes based on visual  
424 stimuli presented to a single eye, and to then navigate these routes using the other (naive) eye.  
425 Bees reaching the end of the tunnel had to turn right or left, one of these choices being correct  
426 and leading to reward while the other not. Using the narrow tunnel for a walking bee ensured  
427 that what was presented in the lateral walls of the tunnel was the only visible cue to a given eye.  
428 They found that stimuli encountered by different eyes could be associated with different routes  
429 and that bees could learn to associate a color with a turning direction based on monocular cues.

430 A similar approach was used by Menzel (Menzel, 2009) who trained bees to turn either left or  
431 right in a narrow T-maze depending on the sequence of colors (blue, yellow) experienced at  
432 four positions in the access arm. In this way he aimed at studying the learning of sequential  
433 visual configurations as predictive of reward. The results showed that visual cues differed in  
434 their capacity to predict reward when presented alone in a test at one of the four positions of  
435 the access tunnel. The position closest to the maze branching had the highest predictive value  
436 while that at the entrance of the maze had the lowest value. Thus, the four positions were  
437 equipped with different salience scores, which reflected probably their contiguity to reward,  
438 and which added up independently, although in some tests configuring of sequential patterns  
439 was also observed.

440 Walking setups have been also used to study aversive learning as they offered the possibility of  
441 delivering punishment (e.g. electric shock) via the tarsi of the walking bees. For instance,  
442 Nicholas H. Kirkerud and collaborators established an automated setup to study a passive-  
443 avoidance task that they called APIS, the Automatic Performance Index System (Kirkerud et  
444 al., 2013). It's an enclosed walking channel where the interior is covered with an electric grid,  
445 and where presentation of odors from either end can be combined with weak electric shocks to  
446 form aversive associations. To quantify behavioral responses, the movement of the bee is  
447 monitored by an automatic tracking system. Number of escapes from one side to the other,

448 changes in velocity as well as distance and time spent away from the punished odor are  
449 measured to describe the bee's learning capabilities (Kirkerud et al., 2013). This setup was then  
450 adapted for color learning, where one half of the assay is illuminated with one color paired with  
451 electric shock and the other half was illuminated with light of a different wavelength and not  
452 paired with shocks. The unrestrained bee could run away from the light stimulus and thereby  
453 associate one wavelength with punishment, and the other with safety (Fig. 4a) (Kirkerud et al.,  
454 2017). A similar setup (Fig. 4b) was used by Agarwal and collaborators to explore the influence  
455 of dopamine (DA) and octopamine (OA) on avoidance learning (Agarwal et al., 2011). In this  
456 study free walking honeybees had to learn the association between a mild electric shock and a  
457 special color cue. After five trials control bees successfully learned the association and stopped  
458 going to the color side associated with the shock. OA impaired avoidance learning as OA treated  
459 bees spent more time in the shock paired compartment and a lower proportion of insects reached  
460 complete avoidance. DA on the other hand improved the learning as treated bees spent less  
461 time in the shock paired compartment than control bees. Thus the reward and punishment  
462 pathways are inter-connected as OA is known to be involved in motivation, reward, and  
463 modulation of motor functions in insects (Schwaerzel et al., 2003). Plath et al also used a setup  
464 adapted from APIS to explore the role of the central complex and of the mushroom bodies in  
465 aversive color learning (Plath et al., 2017). They found that silencing either the central complex  
466 or the medial lobes of the mushroom bodies (Fig. 15) impaired the ability of the bee to associate  
467 the light field with the shock. On the other hand, inactivating one collar region of the mushroom  
468 bodies calyx (Fig. 15.C) did not affect learning in this assay (Plath et al., 2017). Electric shock  
469 associated with color lights in a double-chamber setup was also used, yet not for aversive color  
470 discrimination learning, as in the cases mentioned above, but for phototactic suppression based  
471 on aversive learning. In this setup termed ICARUS bees learned to suppress their spontaneous  
472 attraction toward a blue lit compartment in which they would receive a mild electric shock

473 (Fig.4c) (Marchal et al., 2019). The setup is made of two illuminated chambers, initially both  
474 chambers are illuminated in red, not visible to the bee (640 nm), then the chamber not currently  
475 occupied by the bee is lit in blue, through positive phototaxy the naive insect will spontaneously  
476 enter the lit chamber and receive an electric shock. The delay between the beginning of the  
477 illumination and the moment the bee crosses the threshold is recorded and serves as a measure  
478 of learning. This protocol was sufficient to induce visual learning as bees were able to  
479 successfully repress their spontaneous phototactic response toward the blue light and to create  
480 long term memory as honeybees still repressed their attraction to blue light 24 h after the last  
481 conditioning trial. Finally, they performed RT-qPCR in individual brains of successfully trained  
482 animals focusing on expression levels of the three dopamine-receptor genes *Amdop1*, *Amdop2*,  
483 and *Amdop3*. Coherent with Agarwal's results on DA (Agarwal et al., 2011), found an up-  
484 regulation of the dopaminergic receptor gene *Amdop1* in the calyces of the mushroom bodies  
485 as a result of the conditioning (Marchal et al., 2019).

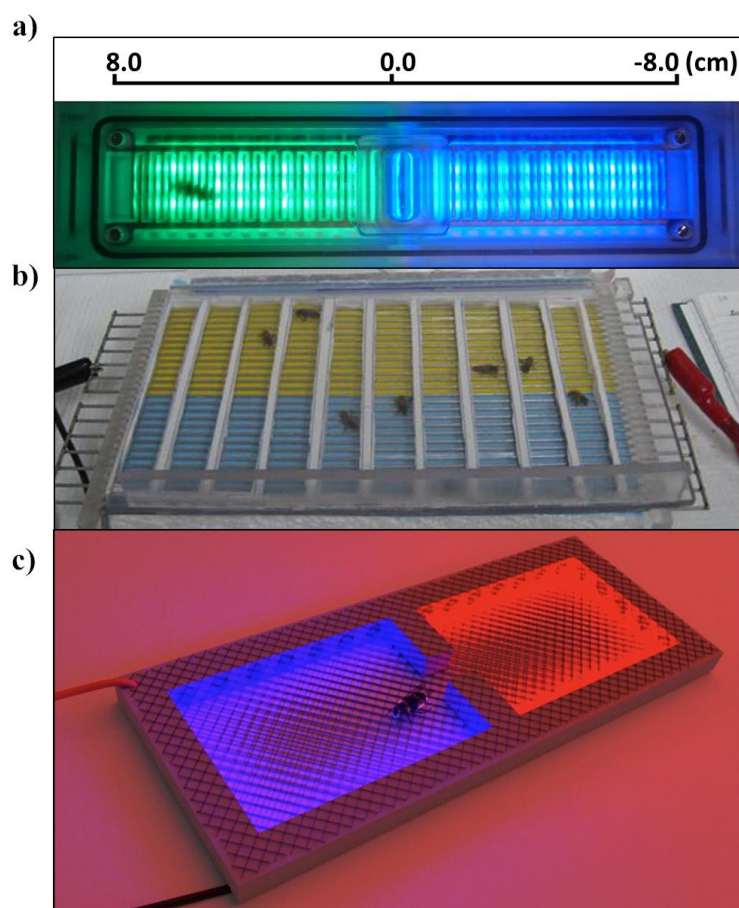

486

487 **Figure 4. Shuttle boxes for aversive visual learning in bees.** In these setups, the bees are  
 488 located in an elongated chamber where they shuttle back and forth. During a conditioning trial,  
 489 each half of the chamber is identified by a visual cue (colored sheets of paper or color LEDs)  
 490 and one of these cues is associated with electric shock delivered by a shock grid whenever the  
 491 bees enters the compartment. The position of the bees is either assessed by a number of infrared  
 492 barriers (a) or manually (b and c). (a) APIS setup taken from Kirkerud et al., 2017. (b) Taken  
 493 from Agarwal et al., 2011. (c) Taken from Marchal et al., 2019.

494 Both APIS and ICARUS give more control over the timing of the experiments than under free  
 495 flight conditions because the whole experiment can take place in the lab and the bees do not  
 496 return to the hive. It is then possible to perform more invasive experiments like local  
 497 inactivation of brain structures, using neuropharmacological blockade of target receptors  
 498 (Agarwal et al., 2011), transiently inactivating specific brain structure with anesthetic (Plath et  
 499 al., 2017), or quantifying relative levels of gene expression in key brain structures following  
 500 aversive learning (Marchal et al., 2019).

501 In order to study appetitive conditioning in more controlled conditions than free flight it is  
502 possible to adapt the Y-maze used with free flying honeybees to a semi-restraining version in  
503 which bees move freely within a miniature maze but do not return to the hive in between trials  
504 (Buatois et al., 2018; Bestea et al., 2022). Such a maze had detachable end sections that could  
505 be closed and moved to the start of the maze after each choice. In this way, a bee was forced to  
506 do consecutive choices by translocating it repeated times to the start of the maze. This setup  
507 was used, among others, to control for the effect of manipulated appetitive motivation, which  
508 would change dramatically if the bee returns to the hive and unload the collected food (Bestea  
509 et al., 2022).

510 Thanks to those protocols it has been possible to investigate further the underlying mechanisms  
511 of visual learning by coupling controlled behavioral experiments with neural analyses of  
512 targeted regions of the brain. However, because the insect can move freely, the analyses  
513 performed are relatively crude as they proposed ‘static’ views of neural activation (via gene  
514 expression analyses) or because they targeted broad areas via pharmacological blockade. In all  
515 cases, what is missing is the possibility to couple the study of behavioral performances with an  
516 online recording of neural activity, which is of fundamental importance to characterize the  
517 neural signature of visual learning and memory.

#### 518 **Visual learning under full immobilization: conditioning of appetitive and aversive reflexes**

519 One of the most widely used protocol to investigate learning and memory in bees is the  
520 appetitive reflex elicited by chemosensory contact of sucrose solution with sucrose receptors  
521 located on the antennae and the tarsi (Minnich, 1921; Frings, 1944; Frings and Frings, 1949).  
522 This response termed PER (Proboscis Extension Reflex) has been used extensively to study  
523 olfactory learning and memory (Giurfa, 2007). PER conditioning as also been adapted to other  
524 hymenoptera like bumblebees (Laloi et al., 1999; Riveros and Gronenberg, 2009). As described

525 earlier, individually harnessed bees learn the association between a neutral odorant and a  
526 sucrose reward such that the odorant ends up eliciting PER (Fig.5).

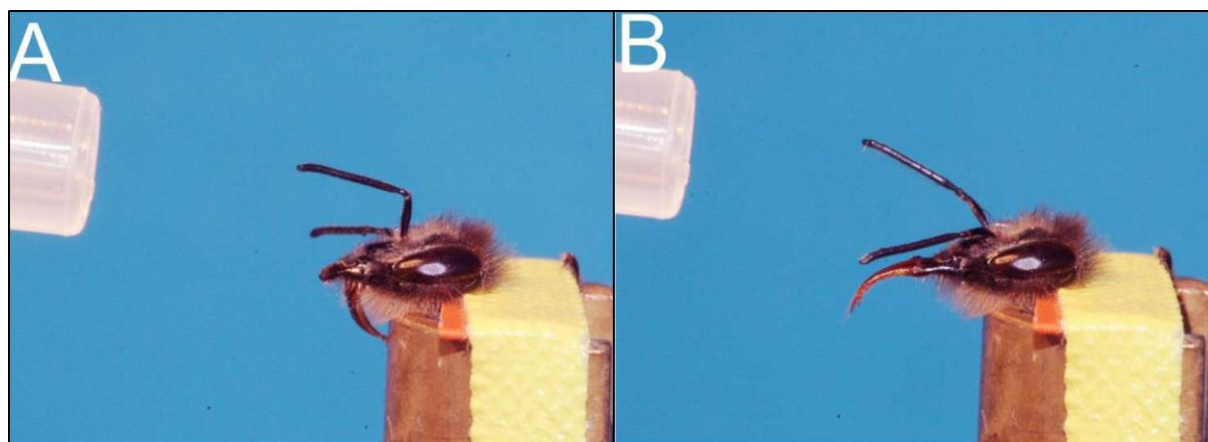

527

528 **Figure 5. Olfactory conditioning of the proboscis extension reflex.** (A) Before conditioning,  
529 stimulation with the neutral odor does not elicit the PER. (B) After forward pairing of odor  
530 stimulation and sucrose solution the honeybee responds to the odor with PER. Taken from  
531 (Scheiner et al., 2013).

532 The PER protocol was originally conceived to study visual learning. In its first version,  
533 published in 1957, Kuwabara introduced the protocol to study Pavlovian visual learning. Yet,  
534 he realized that learning would be only possible if the antennae of the bee were sectioned. He  
535 mentioned that this procedure was necessary to allow the acquisition of color-reward  
536 associations and consequent color-dependent PER response because restrained bees with intact  
537 antennae apparently developed unspecific PER responses to the water vapor from the small  
538 spoon used to deliver sucrose solution as reward (Kuwabara, 1957). Fifteen years after  
539 Kuwabara's original report, another study reported results using visual-PER conditioning of  
540 honeybees with intact antennae. But it required up to 50-60 training trials to achieve learning  
541 (Masuhr and Menzel, 1972). Another study reported no significant acquisition of visual-  
542 induced PER in bees with intact antennae during a 6-trial pre-training phase in which bees had  
543 to associate a white-light stimulus with sucrose reward (Gerber and Smith, 1998). Only later,  
544 the group of Takeo Kubo reproduced Kuwabara's results on visual PER conditioning but  
545 sectioning the antennae again (Hori et al., 2006, 2007). The first study compared visual learning

546 performances of antennae-deprived and intact restrained bees, and found that only antennae-  
547 deprived bees were able to acquire significant visual-induced PER after 20 trials of classical  
548 conditioning using green (540 nm) or red light (618 nm) as conditioned stimulus (Hori et al.,  
549 2006) or, in a different work, motion cues which could simulate backward or forward optic flow  
550 (Hori et al., 2007). Red light was used “to activate exclusively the L-receptor type”, thus as a  
551 case of achromatic visual conditioning. In the case of motion cues, bees were able to be  
552 conditioned equally well to forward and backward movement, and were able to specifically  
553 respond to the conditioned motion as bees conditioned to backward motion responded  
554 significantly more (44.4%) to backward than to forward motions (14.8%) (Hori et al., 2007).

555 More recent works found that intact restrained honeybees can acquire visually-induced PER  
556 responses both in absolute and differential visual conditioning paradigms (Dobrin and  
557 Fahrbach, 2012; Sakura et al., 2012; Jernigan et al., 2014; Balamurali et al., 2015). Contrary to  
558 previous studies (Hori et al., 2007, 2006; T. Mota et al., 2011), some of these authors found that  
559 antennae amputation even impaired visual-PER acquisition (Jernigan et al., 2014). The  
560 potential bias due to responses to water vapor perception when training the bees with intact  
561 antennae was not discussed in these papers. Moreover, Dobrin and Fahrbach showed reduced  
562 discrimination performances when a wet toothpick was presented to the bees in the CS- trials  
563 instead of a dry toothpick (Dobrin and Fahrbach, 2012). Thus, when the unambiguous presence  
564 of water could not be used as an additional predictive factor of reward, the bees’ selective  
565 responses to the conditioned color dropped significantly suggesting a crucial influence of this  
566 factor. Thus, at the present time, the role and potential interference of the antennae on visual  
567 PER conditioning, and the causes for this interference remain unclear.

568 With or without antennae, visual learning performances in PER conditioning have never  
569 reached the levels usually observed in free-flying bees trained to visual stimuli, often  
570 characterized by fast acquisition rates and high percentages of correct choices (70–100%) at the

571 end of training (M. Giurfa et al., 1996; Dyer and Neumeyer, 2005; Avarguès-Weber et al., 2010)  
572 or the levels that are characteristic of olfactory PER conditioning, which allows reaching a  
573 plateau of 80-90% correct choices in the case of a salient odorant (Bitterman et al., 1983; Giurfa  
574 and Sandoz, 2012). Also, the number of conditioning trials required to reach a plateau in the  
575 learning curve is dramatically different between visual and olfactory conditioning of PER.  
576 While few trials (usually three to five) are required for successful olfactory conditioning of PER  
577 (Bitterman et al., 1983; Guerrieri et al., 2005; Matsumoto et al., 2012), a higher number (6 to  
578 20) of trials is required for visual conditioning of PER and acquisition levels are substantially  
579 lower (40%) (Hori et al., 2006, 2007).

580 Therefore, visual PER in its current state does not meet the expectations set by olfactory PER  
581 as it is not only inconvenient to use, with high number of trial and antennae removal, but also  
582 has poor learning performances.

583 In order to study aversive visual learning in restrained bees, it is possible to use the sting  
584 extension response (SER), which is defensive behavior of bees elicited by potentially noxious  
585 stimuli (Breed et al., 2004). It is possible to elicit SER in laboratory through the application of  
586 an electric shock to the thorax (Núñez et al., 1997). This lead to the implementation of an  
587 aversive olfactory conditioning protocol (Vergoz et al., 2007). Honeybees were fixed  
588 individually on a metallic holder so that they build a bridge between two electrodes through  
589 which a mild electric shock can be delivered to elicit the SER. A 2s electric shock served as the  
590 US and was paired with a 5s odor pulse as CS (Fig.6) (Vergoz et al., 2007). This protocol was  
591 later adapted for visual learning (Fig.6a) (Theo Mota et al., 2011a) as an alternative to visual  
592 PER. Bees were able to discriminate two colors, green and blue, that varied both in their  
593 chromatic and achromatic properties, reaching 40% of specific response to the reinforced color  
594 after 6 trials. They were also able to discriminate colors that varied only in either their chromatic  
595 or achromatic properties with the same percentage of success at the last trial. Lastly the authors

596 showed that not only antennae ablation was not necessary for this conditioning but that it  
597 decrease bees' performances (Theo Mota et al., 2011a). However, due spatial constraints (the  
598 sting had to stay visible to the experimenter) the visual stimulus could only be projected on one  
599 eye, even though we know that bees can learn visual exposure through monocular exposure  
600 (Masuhr and Menzel, 1972) this is limitation for further exploration of the underlying  
601 mechanism of visual learning. Moreover, Mota and collaborators' study showed a constant  
602 unspecific response of about 20% in addition to the low percentage of conditioned response  
603 (40%) so visual SER is pretty far from the performances observed with olfactory PER.

604 Thus visual SER does not meet the expectations set by olfactory PER for reasons similar to the  
605 ones mentioned for visual PER.

606

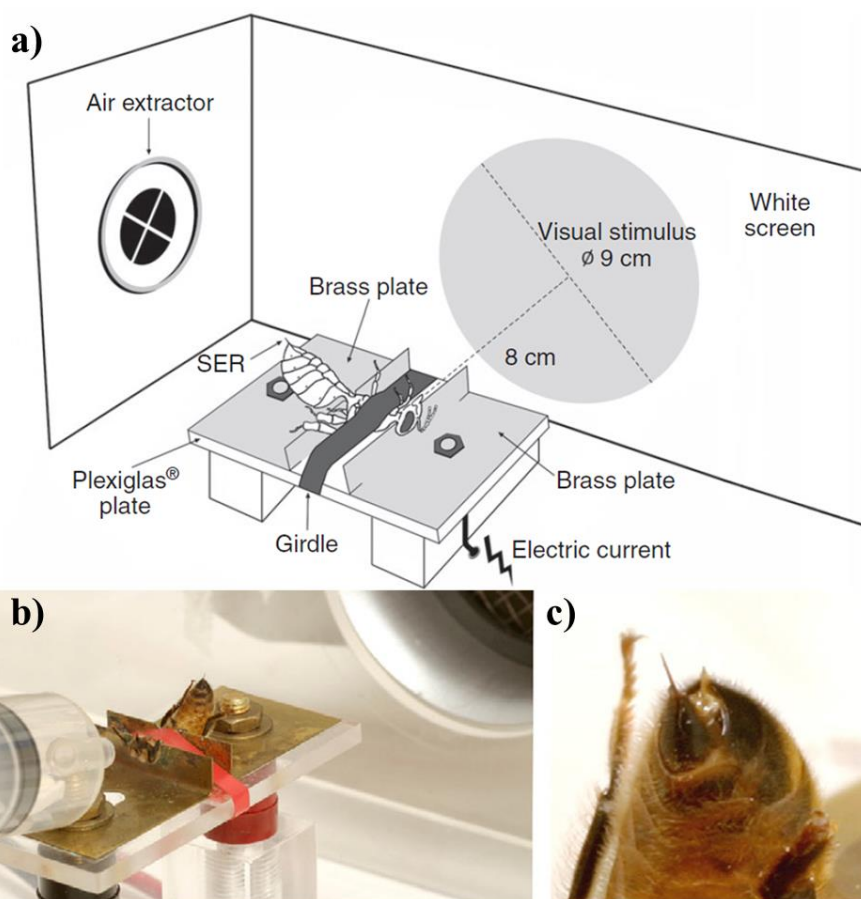

607

608 **Figure 6. Visual conditioning of the sting extension reflex (SER).** (a) Experimental setup, a  
 609 honeybee was individually harnessed in a holder allowing the delivery of a mild electric shock.  
 610 The visual stimulus was presented on a white screen to the right eye of the harnessed bee. Taken  
 611 from Theo Mota et al., 2011a. (b) Picture of a bee harnessed in a SER setup. Taken from  
 612 (Tedjakumala and Giurfa, 2013) (c) Picture of a sting extension. Taken from (Tedjakumala and  
 613 Giurfa, 2013)

614 Overall, it is forceful to conclude that protocols with fully immobilized animals have not  
 615 yielded satisfactory results for visual conditioning in honeybees. This cannot be related to the  
 616 full immobilization as a stressful component as bees learn efficiently odorants under the same  
 617 experimental conditions. One possible explanation is that full immobilization precludes the  
 618 possibility of active vision, i.e. the active extraction of visual information from the environment  
 619 by means of an animal's movements and sensing. Thus, an experimental approach in which  
 620 immobilization exists but leaves some degrees of freedom for active sensing of visual stimuli  
 621 could be a way to overcome the problems mentioned above.

## 622 Virtual Reality: an innovative approach to study visual learning in bees

623 Virtual reality (VR) is a scenario built on the basis of artificial sensory stimuli, often generated  
624 by computer, that gives the feeling of immersion in an actual world as it allows moving and  
625 interacting within that environment while being in fact stationary in the real world.

626 For walking insects the development of VR systems started more than 70 years ago with a  
627 pioneering setup published by Bernhard Hassenstein to characterize for the first time optomotor  
628 responses in beetles (Hassenstein, 1950). This setup was not a true VR in the sense that it did  
629 not create a visual environment for the beetle under study. Yet the visual panorama was coupled  
630 to the beetle's movements. The insect was tethered onto a very lightweight 'Y-maze globe'  
631 made of thin straws, which turned below the beetle as the beetle 'walked' along a blade of  
632 straw, thus repeatedly confronting the beetle with Y-maze choices of diverging straws. The  
633 tethered beetle could then be exposed to highly controlled, moving visual stimuli, namely a  
634 cylinder with vertical black and white stripes, allowing the simultaneous recording of its  
635 directional choices on the globe in response to the moving stripes (Hassenstein, 1951).

636 Later a flight simulator was built by Götz to study the optical properties of the compound eye  
637 of *Drosophila melanogaster*. It consisted of a torque meter suspended in the middle of a  
638 cylinder with textured walls. The fly was suspended by its thorax to the torque meter which was  
639 thus able to measure the rotations of the fly as it reacted to the movements of the cylinder walls.  
640 It was an open loop setup where the fly could react to the stimuli presented to it but could not  
641 control their movements (Fig.7) (Götz, 1964). Measuring the optomotor response of the flies to  
642 movement of the walls, Götz was able to show that the perception of motion depends only on  
643 the temporal, not on the spatial phase relations between periodic intensity variations in  
644 neighboring ommatidia.

645

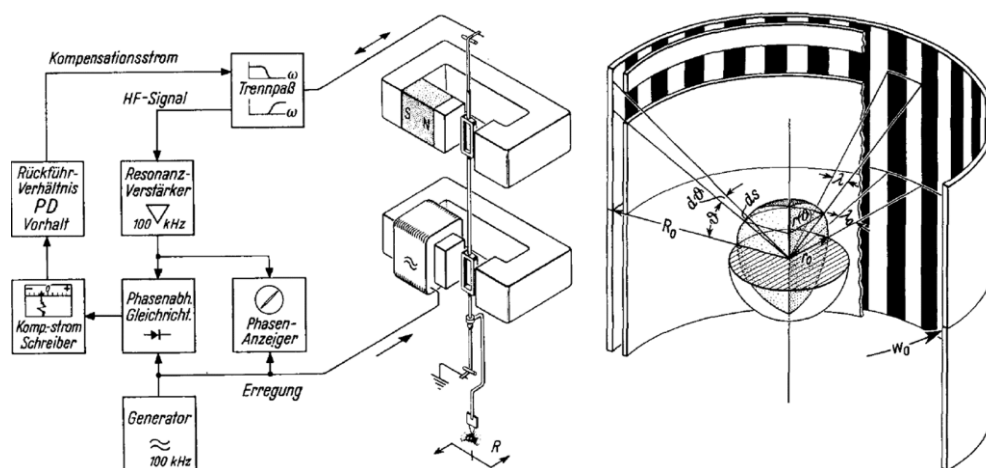

646 **Figure 7. Flight simulator build by Götz.** (Left) Electric diagram and schematics of the torque  
 647 meter used to measure the optomotor response of the fly. (right) Textured wall used to induce  
 648 optomotor response in the fly. Taken from Götz, 1964

649 Nowadays thanks to the advancement of computers, the range of virtual realities that could be  
 650 generated became virtually infinite, ranging from simple shapes and colors to impossible world  
 651 with non-Euclidian geometries. Thus new approaches and systems were produced to test a wide  
 652 variety of hypotheses on bee visual behavior.

### 653 Studying navigation and attentional processes

654 VR for honeybees made its first significant start with a flight simulator build by Luu et al (Luu  
 655 et al., 2011). A tethered bee was suspended in the middle of four LCD monitors that displayed  
 656 a moving panorama. They could thus study the behavioral response of bees to being passively  
 657 exposed to a moving panorama, as a way to examine whether and how optic flow affects body  
 658 posture during flight. The authors were able to make the tethered bees fly in these experimental  
 659 conditions and noticed that, upon such suspended flight, bees slightly raise their abdomen, a  
 660 response that is interpreted as a 'streamlining response' (Fig8), presumably to reduce  
 661 aerodynamic drag. This response was elicited by pure visual exposure (Luu et al., 2011) and  
 662 was strongest when the image motion was in the direction that would be experienced during  
 663 forward flight and when it covered the full visual panorama of the bee. It was highly sensitive

664 in the lateral rather than in the frontal and rear fields, and it was also modulated by air-flow  
 665 cues simulating head-wind (Taylor et al., 2013).

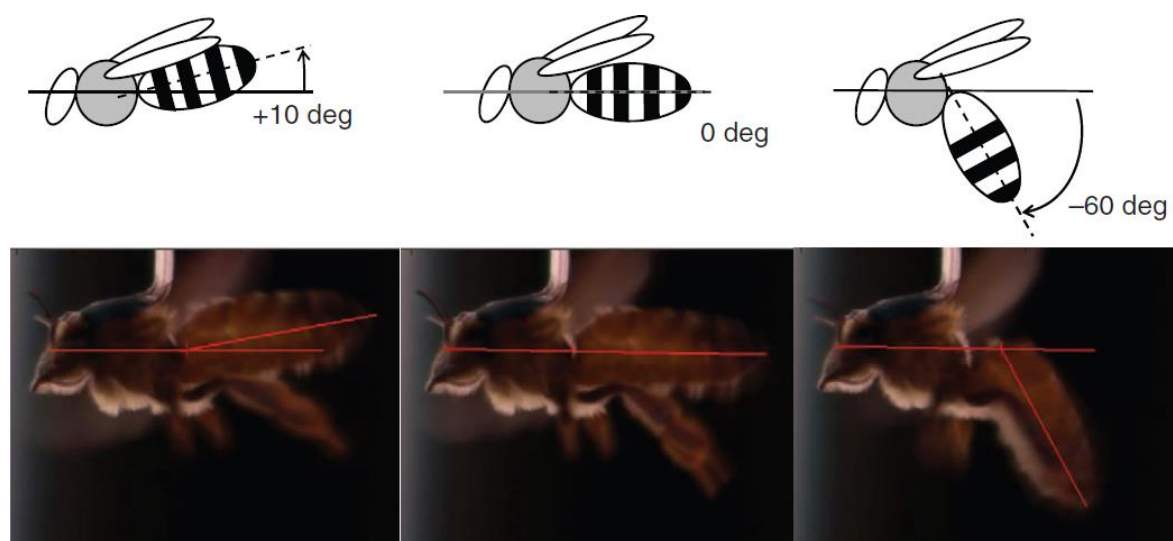

666

667 **Figure 8. Illustration of the measurement of the streamlining response.** The streamlining  
 668 response is defined as the orientation of the abdomen relative to the thorax. The sketches  
 669 illustrate the definition of the response, and the images give three examples of how this is used  
 670 to measure the response. Taken from Luu et al., 2011.

671 More recently another flying VR was established to study the relative importance of motion  
 672 cues and occlusion cues in flight navigation in *Bombus ignitus*. Bumblebees could freely move  
 673 within an enclosed Plexiglass arena ( $62 \times 32 \times 42$  cm), with a LCD monitor at the floor of the  
 674 arena. The movement of the bee where tracked in to two camera placed orthogonally to each  
 675 other outside the arena. The surface displayed on the monitor could thus be updated according  
 676 to the movement of the bumblebee thereby creating a virtual floor that could be positioned at  
 677 an arbitrary height compared to the real floor (Fig.9a) (Frasnelli et al., 2018). Bumblebees were  
 678 first trained to feed from a static target, a blue disc, displayed on the floor of the arena before  
 679 being submitted to various configurations of virtual floor they had to go through to reach the  
 680 target. The VR displayed an elevated platform above the floor where the target was positioned,  
 681 the elevated platform had a hole through which the insect could fly to reach the target below.  
 682 In order to create the illusion that the elevated platform is above the floor, the authors controlled  
 683 two parameters: motion cues and occlusion cues. Motion cues are the apparent movement speed

684 of different objects: objects that appear to move fast are close, while slower objects appear to  
685 be further away. A typical way to explain that effect is to describe the experience one has when  
686 being a passenger on the highway, when looking out the side window, objects near the car  
687 appear to move really fast, while objects further away move slower and really distant objects  
688 on the horizon appear almost still. Thus, by making the elevated platform move slower than the  
689 virtual floor in response to the bee movements, it would appear to be closer to the insect.  
690 Occlusion cues are easier to describe; the closest object should hide the object situated behind  
691 it. This setup was sufficient to produce a believable illusion for the bumblebees as they tried to  
692 avoid the virtual elevated platform, and slowed down and extended their leg when getting close  
693 in an attempt to land on it. The genius of this setup, and one of the real strength of VR in general,  
694 is that it allowed to create impossible realities where motion cues and occlusion cues were  
695 conflicting. It means that the floor would move slower than the platform (motion cues), but  
696 would mask the platform (occlusion clues). The authors were thus able to evaluate what cues  
697 takes precedence for the bumblebee flight navigation by creating this conflicting situation  
698 (Fig.9b). The bumblebees flew through the occluding texture and avoided the regions with  
699 higher motion speed to reach the target (Fig.9b), thereby showing that they prioritize motion  
700 cues over occlusion clues for flight navigation (Frasnelli et al., 2018).

701

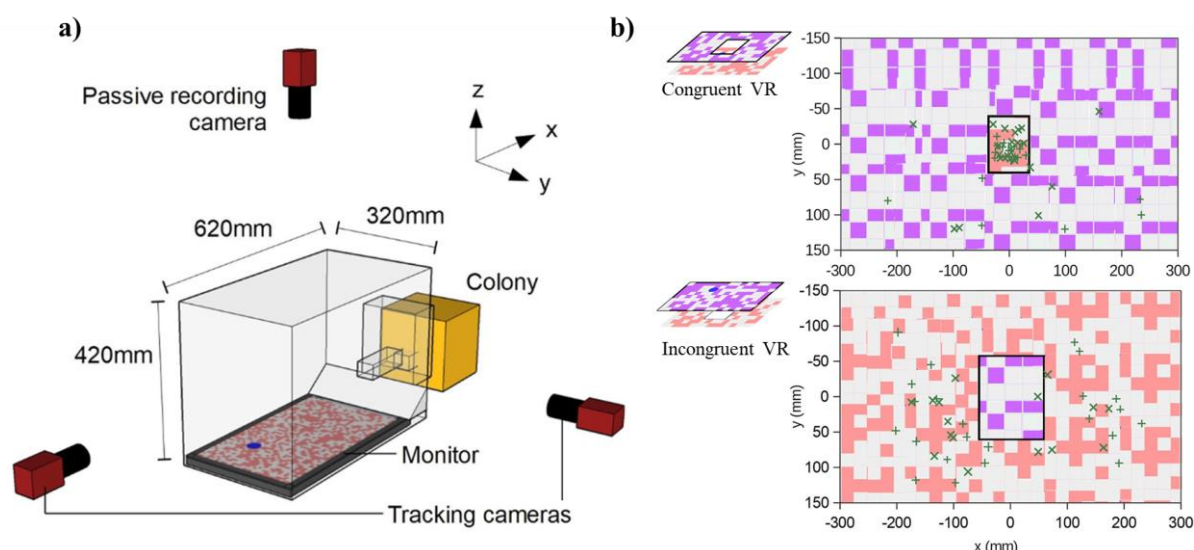

702

703 **Figure 9. Bumblebee free flight VR arena.** (a) Diagram of the flight arena. (b) Behaviour  
 704 results from congruent (top) and incongruent (bottom) VR. Virtual platform is in purple and  
 705 virtual floor in salmon. The green crosses represent the positions at which individuals initially  
 706 descended through the plane of the virtual platform. Adapted from Frasnelli et al., 2018.

707 Many setups have also been made to study walking bees (Schultheiss et al., 2017). They are  
 708 called locomotion compensators, or running spheres, use either a light weight ball suspended  
 709 on an airflow or a ball controlled by precise servomotors that compensate the movement of the  
 710 insect to always keep it at the top of the ball. This thus creates an omnidirectional treadmill on  
 711 which the bee can run indefinitely (Fig.10). Ball movements can be tracked accurately by  
 712 appropriate optical mouse sensors (Fig10a) (Taylor et al., 2015) or a video camera (Moore et  
 713 al., 2014). This kind of device has been used for more than half a century to study different  
 714 aspects of insect behavior, in particular stereotyped responses to environmental stimuli  
 715 (Kramer, 1976). Recent progress in video tracking and computer controlled systems have  
 716 allowed to present the insect with a visual environment that is directly updated by its  
 717 movements walking stationary on the treadmill (closed-loop). Paulk et al. (Paulk et al., 2014a)  
 718 used a variant of such a closed-loop VR setup for studying attention-like processes in tethered  
 719 walking honeybees. Bees walking stationary in the middle of an LED arena were presented  
 720 with one or two competing green vertical bars separated by  $90^\circ$  and flickering at different  
 721 frequencies. The goal was to confront the tethered bee with two competing percepts, which

722 would induce sharing attentional resources between them given the fact that bees tend to fixate  
 723 either stimulus. The authors were able to combine the recording of behavioral fixation of these  
 724 stimuli with extracellular electrophysiological recordings of neural activity in different parts of  
 725 the bee brain, inspired by earlier work on *Drosophila* (Van Swinderen, 2012). Using this  
 726 method, it was shown that attention-like processes had a neural correlate at the level of the optic  
 727 lobes before the bee displayed a behavioral choice. No such correlate was detected at the level  
 728 of the mushroom bodies probably because of the sparse coding occurring at this level, which  
 729 renders difficult detecting electrophysiological signals

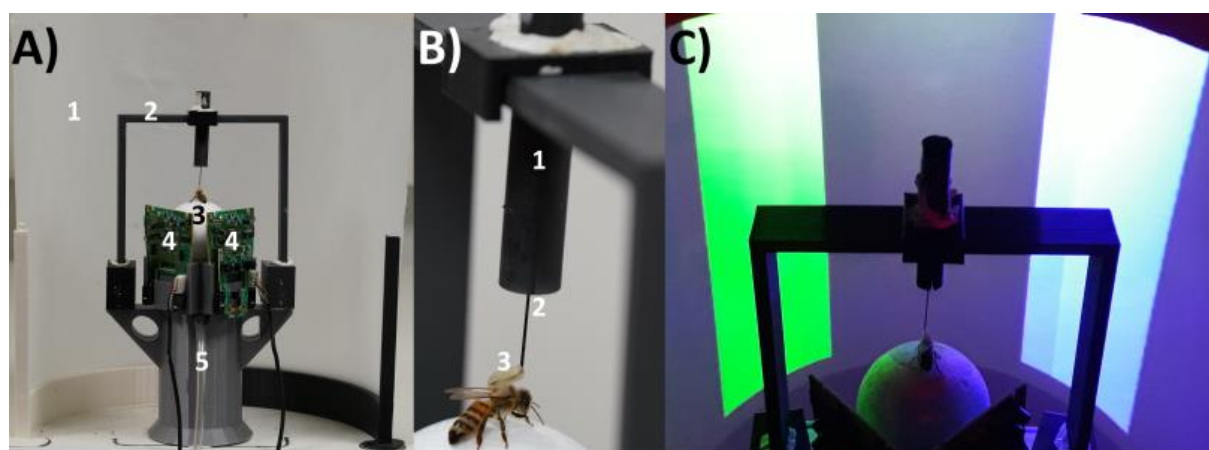

730

731 **Figure 10. VR setup using a locomotion compensator.** A) Global view of the VR system. 1:  
 732 Semicircular projection screen made of tracing paper. 2: Holding frame to place the tethered  
 733 bee on the treadmill. 3: Treadmill made of a Styrofoam ball floating on an air cushion. 4:  
 734 Infrared mouse optic sensors allowing to record the displacement of the ball. 5: Air input. B)  
 735 The tethering system. 1: Plastic cylinder containing a glass cannula into which a steel needle is  
 736 inserted. 2: Needle attached to the thorax of the bee. 3: Its curved end is fixed to the thorax by  
 737 means of melted bee wax. C) Example of stimuli presented to the insect, her two colored  
 738 cuboids.

739 The use of closed-loop instead of open-loop controlled visual stimuli seems to be an important  
 740 parameter, as it increases the temporal coordination of neural activity in the insect brain (Paulk  
 741 et al., 2014b, 2015). Closed loop conditions also seem to modulate neural activity as early as  
 742 the medulla (Rusch et al., 2021). Indeed, when honeybees had behavioral control over the  
 743 horizontal displacement of the visual scene, a subset of spiking neurons, in the medulla,

744 exhibited increased responses for the duration of the stimulus and before the onset of behavioral  
745 fixation, but not during their replay in open loop (Rusch et al., 2021).

746 The VR setups used are constantly evolving, and each study so far has used slightly different  
747 parameters and materials (Schultheiss et al., 2017). Most importantly, the techniques used for  
748 visual stimulus presentation have changed from LCD to LED screens, as LCD screens do not  
749 allow for easy control over parameters such as color, brightness, light polarization or flicker  
750 frequency (D'Eath, 1998). LED bulbs allow precise control, and arrays of bulbs can be adjusted  
751 to match the visual resolution of bee eyes (Reiser and Dickinson, 2008). Another way to display  
752 stimuli that is cheaper than LED arrays and more flexible than LED screens is the use of video  
753 projectors, which offer similar control over color and brightness and can display images on  
754 screens of different shapes such as spheres or cylinders around the insect (Buatois et al., 2017,  
755 2018). The latest development of VR in *Drosophila* allowed to build setups as cheap as \$300  
756 (Loesche and Reiser, 2021). This setup could probably be adapted to bees by scaling up the  
757 treadmill.

#### 758 Studying associative learning and memory

759 The first two studies exploring visual learning and discrimination of honeybees walking  
760 stationary on a trackball and facing virtual visual stimuli came out in 2017 (Buatois et al., 2017;  
761 Rusch et al., 2017). In both cases, a visual projection system displayed different visual stimuli  
762 on a semi-cylindrical screen placed in front of the tethered walking bee. After a pre-test  
763 assessing naïve preference for the two visual stimuli to be discriminated, bees were trained by  
764 pairing one of them with appetitive sucrose solution and the other with aversive quinine  
765 solution. Training was performed under open-loop conditions, presenting one stimulus at a  
766 time. Thus, the tethered bee had no control over the stimulus displacements on the screen.  
767 Thereafter, bees were tested with the two visual stimuli displayed simultaneously and without  
768 reinforcement, to determine whether learning induced a change in the original preference.

769 Buatois et al. showed that when tested in extinction condition (without reward) after 12 trials  
770 in open-loop around 60% of bees chose the CS+ while the rest either chose the CS- (20%) or  
771 didn't make a choice (20%) thus showing that the insects were able to learn the correct  
772 association under open loop condition in the VR setup. They also showed that when presenting  
773 only the CS+ or CS- during the training phase it is not possible to record any discrimination  
774 between CS+ and CS- as the spontaneous phototactic response of bees leads them to always  
775 orientate towards the light (Buatois et al., 2017). Finally they showed that using distilled water  
776 or quinine solution as punishment associated with the CS- was more effective to induce learning  
777 as bees submitted to either dry toothpick or NaCl solution associated with CS- did not learn the  
778 discrimination (Buatois et al., 2017). Those results are really important to guide future  
779 conditioning protocol in choosing appropriate US, and suggest strongly to condition bees under  
780 close-loop condition, in order to offer them a choice between CS+ and CS- at every trial to have  
781 a chance to measure acquisition performance during the learning phase.

782 Similarly, Rusch et al showed that about 60% of bees were able to learn the association after  
783 12 trials, going further they showed that 6 trials were sufficient to get more than 50% of bees  
784 to choose the correct stimulus. Bees were able to learn when CS+ and CS- differed both in  
785 shape and colors or when both CS were circle of different colors but not when they were either  
786 of the same color or square differing only in color. The authors conclude that the color and  
787 shape are learned in non-additive manner as not all combinations of shape-color variation lead  
788 to learning and that they should thus be considered carefully when designing an experiment  
789 (Rusch et al., 2017).

790 As mentioned earlier, one of the problems potentially underlying the poor learning  
791 performances observed in visual PER conditioning is the restriction of active vision, which  
792 precluded – for instance – extracting the borders of objects to better detect their presence. In a  
793 further study, the question of the role of active vision in the VR setup described above was

794 analyzed. Buatois et al. (Buatois et al., 2018) realized two transfer experiments in which the  
795 bees either learned the association within a miniature Y-maze (described earlier), where they  
796 were free to move and explore the visual stimuli projected on the back walls, or while being  
797 tethered and walking stationary in the VR setup, where the control of the visual stimuli was  
798 restricted to a 2D plane (bees could only displace the stimuli laterally to bring them in front of  
799 them or to move away from them). In either case, the transfer consisted in testing bees after  
800 their initial learning in the opposite setup (i.e. from Y-maze to VR or from VR to Y-maze).

801 Approximately 60% of the bees learned the visual discrimination in both conditions. Transfer  
802 from VR to the maze improved significantly the bees' performances: 75% of bees having  
803 chosen the rewarded stimulus (CS+) continued doing so and 100% of bees having chosen the  
804 punished stimulus (CS-) reverted their choice in favor of the CS+. In contrast, no improvement  
805 was seen for these two groups of bees during the reciprocal transfer from the Y-maze to VR. In  
806 this case, bees exhibited inconsistent choices in the VR setup. The asymmetric transfer between  
807 contexts indicates that the information learned in each environment may be different despite  
808 the similar learning success. Moreover, it shows that reducing the possibility of active vision  
809 and movement freedom in the passage from the maze to the VR impairs the expression of visual  
810 learning while increasing them in the reciprocal transfer improves it (Buatois et al., 2018).  
811 These results underline the active nature of visual processing in bees and suggests that current  
812 VR systems require more work to increase immersion, like for example by adding looming and  
813 optic flow to the virtual environment.

814 In 2019 Zwaka et al. published the first results showing electrophysiological recordings from  
815 higher order neurons of honeybees submitted to a visual differential conditioning using a VR  
816 system that consisted of an air-supported spherical treadmill allowing the stationary walking  
817 bee in closed-loop to control a visual environment projected onto a cone-shaped screen from  
818 above (Zwaka et al., 2019). They then used this setup to record A3 mushroom body extrinsic

819 neurons that are known to change their response properties during classical olfactory  
820 conditioning (Haehnel and Menzel, 2010; Filla and Menzel, 2015) and receive input from  
821 Kenyon cells. These neurons provide GABAergic inhibitory feedback onto the mushroom body  
822 calyces and regulate therefore Kenyon cell activity (Rybak and Menzel, 1993; Grünewald,  
823 1999; Zwaka et al., 2018). They have been found to play a crucial role for non-elementary  
824 discriminations in the olfactory domain (Boitard et al., 2015; Devaud et al., 2015a). After  
825 conditioning within the VR, a significant increase in response from the recorded units in  
826 reaction to the rewarded color was found. Yet, this increase was observed in animals for which  
827 no behavioral readout of learning was available, thus raising the question of the signification of  
828 this variation in neural activity.

829 The interest of honeybees as a model for the study of learning and memory resides in the fact  
830 that these animals cannot only solve simple discriminations; they can also solve complex visual  
831 tasks relying on categorization, conceptual learning or numerosity (Giurfa et al., 2001;  
832 Avarguès-Weber et al., 2011b, 2012a; Howard et al., 2019). A form of higher-order learning is  
833 the so-called negative patterning discrimination in which a subject has to learn to respond to  
834 single stimuli (A, B) but not to their conjunction (AB) (Kehoe and Graham, 1988; Whitlow and  
835 Wagner, 1972). The ambiguity of the task resides in the fact that each element (A and B) is as  
836 often reinforced (when presented alone) as non-reinforced (when presented as a compound).  
837 Besides, the problem is difficult given the natural tendency to summation upon compound AB  
838 presentation; in other words, if A and B were positively reinforced, the prediction is that AB  
839 would be twice as good (Whitlow and Wagner, 1972). Yet, in this discrimination, individuals  
840 have to inhibit this summation response and respond only to the single elements. A visual  
841 version of this protocol was established in the VR environment (Buatois et al., 2020). It was  
842 shown that honeybees were able to solve a negative patterning task where A and B were green  
843 and blue gratings against a dark background, while AB was a green-blue composite grating.

844 When conditioned with rewarded green grating (A+) and rewarded blue grating (B+) versus the  
 845 non-rewarded composite green and blue grating (AB-) (Fig11.B), 25% of the bees were able to  
 846 solve both A vs AB and B vs AB tests and about 60% were able to solve at least one of the two.  
 847 The relative low success is explained by the higher complexity of the task compared to  
 848 associative learning. Nevertheless, a non-negligible number of bees were able to solve the task  
 849 thereby proving that honeybees can solve a negative patterning task in VR.

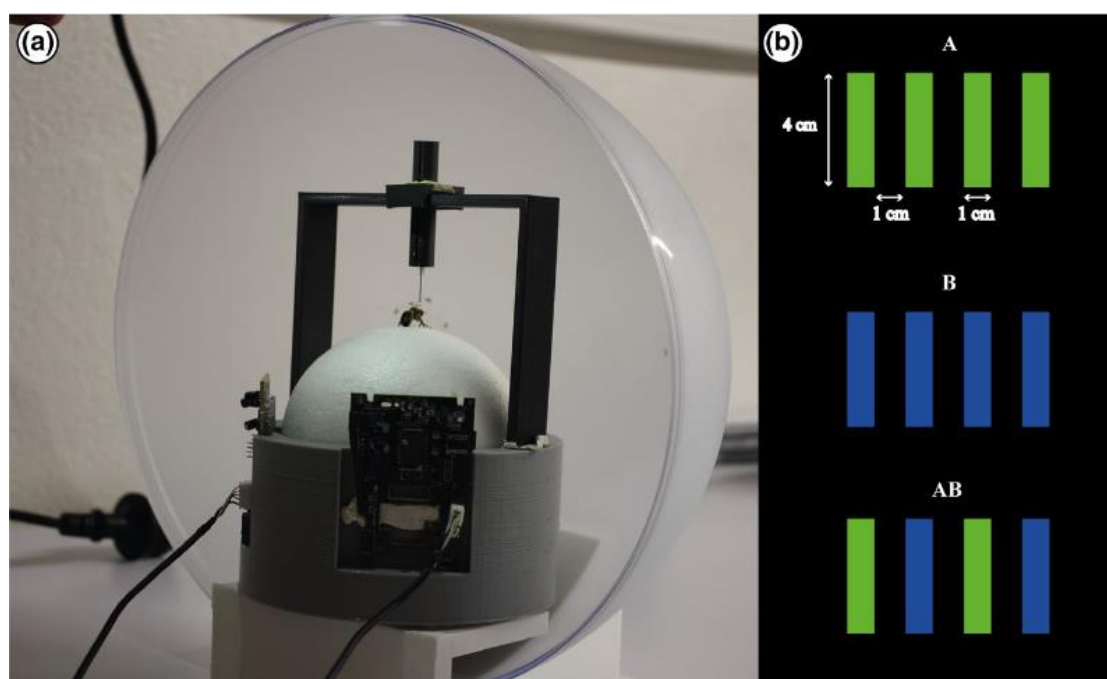

850

851 **Figure 11. Virtual reality set-up and visual stimuli used for negative patterning.** (a) Global  
 852 view of the virtual reality system. (b) Conditioned stimuli: green grating (A), blue grating (B)  
 853 and composite green-blue grating (AB). Taken from Buatois et al., 2020

854 VR thus appears to be an appropriate tool for the study of visual learning as it was successfully  
 855 used for both elemental association (Buatois et al., 2017; Rusch et al., 2017) and non-elemental  
 856 learning (Buatois et al., 2020). Moreover, it shows great promises for live electrophysiological  
 857 recording of learning bees (Rusch et al., 2021; Zwaka et al., 2019).

858

## 859 Benefits and caveats of using virtual reality to study visual learning in bees

860 One of the most important benefits of VR setups is the opportunity to combine controlled  
861 behavioral analyses with invasive analyses of underlying neural performances (Paulk et al.,  
862 2014b; Zwaka et al., 2019; Rusch et al., 2021), which is really difficult in freely-flying or  
863 moving insects (Paffhausen et al., 2020, 2021).

864 In VR, parameters of interest can be manipulated with great precision and flexibility, changing  
865 simple things like shape and color of stimuli (Rusch et al., 2017), or even creating conflict  
866 between properties that are impossible in the natural world (Frasnelli et al., 2018). The  
867 complexity of possible stimuli can vary greatly, ranging from very simple open-loop  
868 presentations (Buatois et al., 2017; Rusch et al., 2017) to naturalistic, immersive, multimodal  
869 scenarios in closed-loop (Fig.12) (Kócsi et al., 2020). Contrary to the real world, VR is under  
870 the complete control of the experimenter, which allows precise control over both the timing of  
871 stimuli, and the bees themselves, including their entire sensory exposure over the course of the  
872 experiment (Schultheiss et al., 2017). This is very important for gene expression analysis as it  
873 allows to normalize the sensory experience across individuals and thus reduce noise and  
874 unspecific response in the results. As tethered bees can be kept for long periods if they are fed  
875 regularly and controlled for their motivation, this opens up the possibility of studying the  
876 neurobiological processes of long-term memory formation.

877

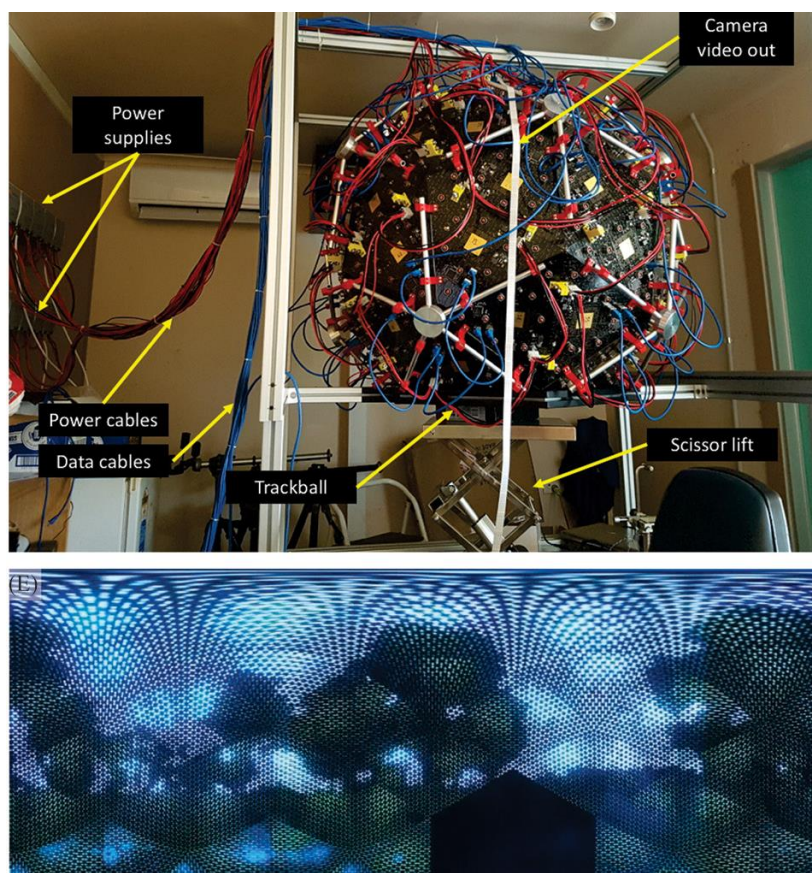

878

879 **Figure 12. Illustration of a naturalistic VR: The Antarium.** (Top) Picture of the fully  
 880 assembled Antarium. (Bottom) The landscape panorama projected by the Antarium LEDs seen  
 881 at 1.5 resolution, about twice the average resolution of ants. Taken from Kócsi et al., 2020.

882 VR systems still present some limitations. Learning success is reduced under such conditions  
 883 compared to performances of freely-flying bees, i.e. 60% versus the typical 90% to 100%  
 884 success rates of freely-flying bees trained to discriminate visual stimuli in Y-mazes (Buatois et  
 885 al., 2017), this might be caused by the tethering that limits free movement and could induce  
 886 some stress in the insect. Moreover, transfer experiments showed an asymmetry in learning  
 887 success between real world and virtual reality conditions suggesting an important role of active  
 888 vision in visual learning (Buatois et al., 2018). Thus, VR setup might need to offer the  
 889 possibility for insects to actively scan objects with not only closed loop conditions but also  
 890 adding a third dimension with looming and optic flow from a virtual background. Additionally,  
 891 under tethered conditions, bees might be lacking some essential proprioceptive input (such as  
 892 antennal deflections during flight) for complete multisensory integration. Missing

893 mechanosensory input is known to influence responses of *Drosophila* to visual stimuli (Mureli  
894 et al., 2017), and is believed to be a cause of ‘cybersickness’ in human applications of VR  
895 (Rebenitsch and Owen, 2016). In some bees, tethering may also induce a decrease or a switch  
896 from the appetitive motivation necessary for visual training to an escape motivation, which will  
897 interfere with learning. Also, when keeping bees tethered for longer periods, a proper control  
898 of appetitive motivation is necessary as well as regular checks of normal motor behavior to  
899 avoid fatigue effects (Schultheiss et al., 2017). Recent development in VR setups for ants also  
900 underlined the need to use a treadmill of appropriate weight in order to make sure that the force  
901 required by the insect to move the ball is similar to the force required to move its own weight  
902 on a flat surface (Dahmen et al., 2017). This parameter seems to have been mostly overlooked  
903 by previous work on honeybees and could be a crucial first step in developing 3D VR as moving  
904 the ball forward would require more force than rotating it around its vertical axis.

905 Finally, one also needs to account for the specific properties of the bee visual system when  
906 designing VR setups (D’Eath, 1998; Fleishman and Endler, 2000). Bees have compound eyes  
907 with photoreceptor sensitivities peaking in the green, blue and UV regions of the spectrum  
908 (Backhaus, 1992). Common technology for creating visual stimuli is, however, designed for  
909 human vision, in which, for example, yellow will be a blend of green and red. As bees cannot  
910 perceive red light, their color perception of such stimulus will be very different (Fleishman et  
911 al., 1998). It is possible to produce images taking into account the properties of insects visual  
912 system (Vorobyev et al., 1997), and this has been successfully done already in several VR  
913 setups (Tedore and Johnsen, 2017; Kócsi et al., 2020). In addition, bee vision has a high  
914 temporal resolution, almost 200 Hz (Srinivasan and Lehrer, 1984), which should therefore be  
915 the minimum frequency of any VR display system. Flicker frequency is an important parameter  
916 as Poll et al. showed that honeybees payed more attention to LEDs flickering at 20–25 Hz,

917 while they avoided higher or lower frequencies (50–100 Hz and 2–4 Hz, respectively) (Poll et  
918 al., 2015).

919 Using a very detailed VR that provides as much information as possible like a three-dimensional  
920 landscape, with polarized light information and optic flow to produce a virtual world as close  
921 as possible to the visual setting in a free-flight experiment, could be a way to overcome the VR  
922 limitations and produce a “perfect” virtual setting. But doing so would be particularly  
923 expensive, in financial terms, but more importantly in terms of the time and technical skills  
924 required to build such a setup (Fig.12). On the other hand, we could investigate the importance  
925 of each parameter like optic flow, depth, polarized light etc. on the bees’ learning performances  
926 in order to design the minimal VR necessary to produce the coherent behavior required for our  
927 purpose. This would be giving us more insight into the insect visual behavior and allow the  
928 emergence of a simple VR paradigm that could be easily disseminated. Making VR more  
929 accessible is important because it would allow teams with limited resources to also be able to  
930 explore underlying mechanisms of visual learning.

931 While it is showing great promises, there’s still work to be done in order for VR systems to  
932 realize their full potential. The technical bar of entry can be lowered, for example, through the  
933 diffusion of open source VR software. And, as suggested by transfer experiments (Buatois et  
934 al., 2018), we need a better understanding of the importance of parameters like optic flow on  
935 the ability of bees to learn efficiently in VR. It provides above all a valid approach to uncover  
936 the neuronal mechanisms of visual learning in bees

### 937 [What do we know of the underlying mechanism of visual learning?](#)

938 Now that we have established what tools were at our disposal and what work was needed to  
939 improve them we need to identify what questions will benefit from the application of those  
940 tools. Despite the difficulties mentioned earlier to access the brain of learning honeybees, their

941 vision has been studied intensively in the past decades. By drawing from those experiments and  
 942 work done on other insects' models, four main regions appear to be involved in visual learning.  
 943 From the periphery to the center: the optic lobes, the ventrolateral neuropils, the central complex  
 944 and the mushroom bodies (Fig.13) (Ito et al., 2014b).

945 In this part we'll review the roles of these different structures for visual learning in order to  
 946 identify good path of exploration for VR experimentation.

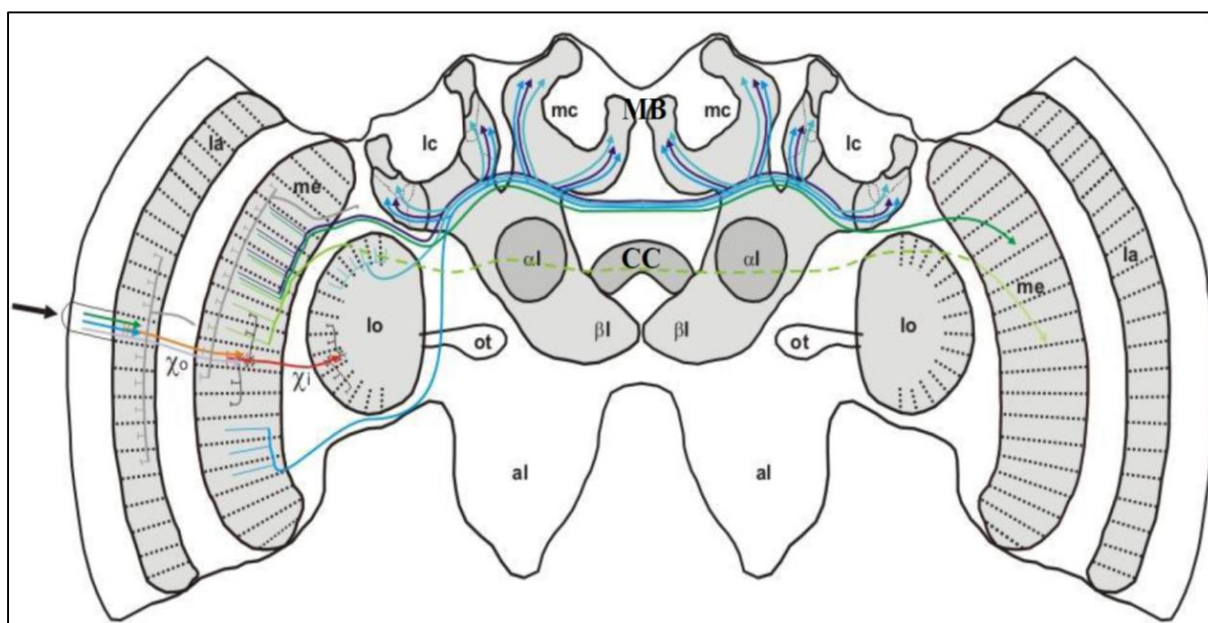

947

948 **Figure 13. The different visual neuronal populations and pathways of the honeybee brain.**  
 949 The black arrow indicates color stimulation. La = lamina,  $\chi_o$  = outer chiasm, me = medulla,  $\chi_i$   
 950 = inner chiasm, lo = lobula, le = lateral calyx of the mushroom bodies, me = median calyx,  $\alpha$  =  
 951 alpha-lobe,  $\beta$  = beta-lobe, al = antennal lobe, ot = anterior optic tuberculum. MB: mushroom  
 952 bodies; CC: central complex. Courtesy of M. Giurfa.

### 953 The Optic lobes:

954 The optic lobes are the first level of integration of visual information. It is a relay point for  
 955 information which arrives from photoreceptors in the compound eyes (Kien and Menzel, 1977).

956 There are three types of photoreceptors, S, M, and L (for short-, mid-, and long-range  
 957 wavelength), peaking in the UV (344 nm), blue (436 nm), and green (544 nm) regions of the  
 958 spectrum, respectively, which have been identified in the honeybee retina (Menzel et al., 1986;  
 959 Menzel, 1979; Peitsch et al., 1992). Photoreceptors are connected to the lamina, the outermost

960 structure of the optic lobes. It is itself connected to the medulla which is connected to the lobula.  
961 These three structures form the three layers of the optic lobes (Ribi, 1975; Avarguès-Weber et  
962 al., 2012b).

963 The lamina is the first visual neuropil in which the axons of the photoreceptors connect to first  
964 order processing interneurons, the lamina monopolar cells (LMC) (Menzel, 1974). In  
965 honeybees, the lamina was shown to contain mainly neurons exhibiting relatively little response  
966 variation across a wide range of wavelengths (Menzel, 1974; Ribi, 1975; Kien and Menzel,  
967 1977). This neuropil is made of thousands of optical cartridges, each receiving an axon bundle  
968 (containing the nine photoreceptor cell axons) from the overlying ommatidium, as well as the  
969 axons of four different types of monopolar cells. The spatial arrangement of photoreceptor  
970 axons and LMCs within a cartridge remains constant throughout the lamina, thus retaining the  
971 retinotopic organization. The outer chiasm forms the connection between the lamina and the  
972 second visual neuropil, the medulla, a structure that contains most of the bee visual system  
973 neurons (Ribi and Scheel, 1981).

974 Fibers coming from the anterior part of the lamina project to the posterior medulla while  
975 posterior fibers from the lamina project to the anterior medulla. Thus, the retinotopic  
976 organization is retained but reversed in the medulla, which is also organized into a columnar  
977 pattern. Medulla columns are highly connected by horizontal fibers (serotonergic or  
978 GABAergic) in contrast with the lamina that has few horizontal connections (Ribi, 1975; Bicker  
979 et al., 1987). In addition, the medulla exhibits a distal proximal laminated architecture  
980 consisting of eight identified layers, oriented orthogonally to the long axis of the columns (Ribi  
981 and Scheel, 1981). Neurons in the medulla already respond with spectral opponency, i.e., with  
982 opponent excitation or inhibition depending on photoreceptor-type input (Kien and Menzel,  
983 1977). These color-opponent neurons, which exhibit combination-sensitive excitatory and/or

984 inhibitory interactions between two or three photoreceptor classes, represent the principal basis  
985 of color vision in honeybees.

986 The third visual neuropil is the lobula, where columnar stratification and retinotopic  
987 organization are preserved mainly in the outer part (Hertel et al., 1987). The inner chiasm forms  
988 the connection between the medulla and the lobula, in which the retinotopic organization is  
989 again reversed anteroposteriorly. Chromatic properties of neurons in the medulla are preserved  
990 and amplified in the lobula, which was also shown to contain distinct color-opponent neurons  
991 (Kien and Menzel, 1977; Hertel, 1980; Hertel and Maronde, 1987). Moreover, different types  
992 of spatial opponent neurons (i.e., with opponent excitation or inhibition depending on the visual  
993 field region or on direction in which the stimulus is presented) were also described in the lobula  
994 (Hertel et al., 1987; Hertel and Maronde, 1987).

995 Inner-layer lobula and medulla neurons, which are more likely to exhibit color-sensitive  
996 responses, send projections to anterior brain areas, particularly to the mushroom bodies and the  
997 anterior ventrolateral protocerebrum (Paulk et al., 2008; Paulk and Gronenberg, 2008; Paulk et  
998 al., 2009a; Dyer et al., 2011). Thus, some of the major visual afferences to the mushroom bodies  
999 are color-sensitive (Gronenberg, 1986; Mauelshagen, 1993; Ehmer and Gronenberg, 2002). On  
1000 the other hand, outer lobula and both inner and outer medulla neurons, project to the posterior  
1001 protocerebrum (Paulk et al., 2009b, 2009a; Dyer et al., 2011). It seems therefore that achromatic  
1002 and chromatic pathways are largely segregated in different steps of visual processing in the bee  
1003 brain. The optic lobes are thus involved in visual processing with the emergence of color vision  
1004 and shape perception thanks to color opponent and spatial opponent neurons.

#### 1005 **The ventrolateral neuropils**

1006 In bees, the ventrolateral neuropils can be divided in at least five main regions: the anterior  
1007 optic tubercle (AOTu), the ventrolateral protocerebrum, the posteriorlateral protocerebrum, the

1008 wedge and the posterior optic tubercle (Ito et al., 2014b). Most ventrolateral neuropils receive  
1009 visual input from the medulla and/or lobula and participate in visual processing (Paulk et al.,  
1010 2009b). As mentioned before, anteroposterior segregation of achromatic and chromatic  
1011 processing was found in the input from the medulla and lobula to the ventrolateral  
1012 protocerebrum of bees (Paulk et al., 2008, 2009b, 2009a; Dyer et al., 2011). Moreover, this  
1013 same gradient of achromatic/chromatic segregation in the anteroposterior brain axis seems to  
1014 be retained at the level of ventrolateral protocerebrum neurons (Paulk et al., 2009b). The most  
1015 prominent optic neuropil in the anterior region of the ventrolateral neuropils is the AOTu. The  
1016 AOTu of bees is compartmentalized in four distinct units (Fig.14) (Theo Mota et al., 2011b).  
1017 The AOTu receives substantial input from the medulla and lobula via the anterior optic tract  
1018 and send output to lateral accessory lobe via the tubercle accessory lobe tract (Fig.14).  
1019 Furthermore, two distinct tracts interconnect the AOTus of both brain hemispheres: the ventral  
1020 inter-tubercle tract and the medial inter-tubercle tract (Fig.14). In addition to these four tracts,  
1021 a specific neuron provides input from the vertical lobe of the mushroom bodies to the AOTu  
1022 (Theo Mota et al., 2011b).

1023 Visual information from the dorsal and ventral parts of the bee eye segregate within different  
1024 AOTu compartments, both at the level of the visual input via the anterior optic tract and of the  
1025 visual output to the contralateral AOTu via intertubercle tracts (Theo Mota et al., 2011b).  
1026 Therefore, visual processing in the AOTu of bees includes a notable spatial component  
1027 characterized by this dorsoventral segregation.

1028 In vivo calcium imaging revealed that stimulation with distinct monochromatic lights  
1029 (ultraviolet [UV], blue, and green) matching the sensitivity of the three photoreceptor types of  
1030 the bee retina induced different signal amplitudes, temporal dynamics, and spatial activity  
1031 patterns in the AOTu intertubercle network, thus revealing intricate chromatic processing  
1032 properties. Green light strongly activated both the dorsal and ventral lobes of the AOTu's major

1033 unit; blue light activated the dorsal lobe more while UV light activated the ventral lobe more.  
 1034 Eye stimulation with mixtures of blue and green light induced suppression phenomena in which  
 1035 responses to the mixture were lower than those to the color components, thus concurring with  
 1036 color-opponent processing. These data reinforce strongly the idea that there is a spatial  
 1037 segregation of color processing in the AOTu, which may serve for navigation purposes (Mota  
 1038 et al., 2013).

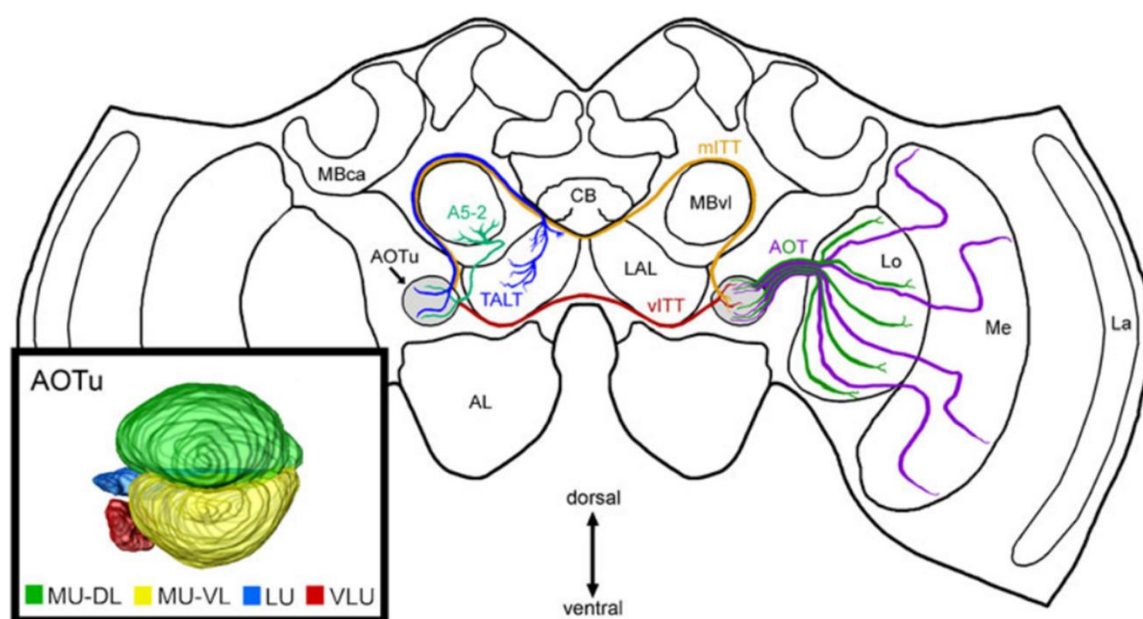

1039

1040 **Figure 14. Three-dimensional structure and neural connectivity of the anterior optic**  
 1041 **tubercle (AOTu).** Three-dimensional reconstruction showing the different AOTu  
 1042 compartments (left inbox): major unit dorsal lobe (MU-DL; green), major unit ventral lobe  
 1043 (MU-VL; yellow), ventrolateral unit (VLU; red), and lateral unit (LU; blue). The schematic  
 1044 diagram summarizes neural pathways connecting the AOTu with other brain neuropils. La =  
 1045 lamina, Me = medulla, Lo = lobula, AL = antennal lobe, MBvl = mushroom body vertical lobe,  
 1046 MBca = mushroom body calyx, CB = central body, LAL = lateral accessory lobe, AOT =  
 1047 anterior optic tract, vITT = ventral inter-tubercle tract, mITT = medial inter-tubercle tract,  
 1048 TALT = tubercle-accessory lobe tract. Taken from Avarguès-Weber et al., 2012b.

#### 1049 The central complex

1050 The central complex (CX) comprises a group of neuropils in the center of the insect brain. One  
 1051 important role of the CX is generation of motor outputs according to processed internal and  
 1052 external stimuli (Pfeiffer and Homberg, 2014; Plath and Barron, 2015). The CX is essential for

1053 the initiation and termination of walking, turning and climbing behavior in fruit flies (Triphan  
1054 et al., 2010), cockroaches (Martin et al., 2015) and crickets (Kai and Okada, 2013) and is  
1055 considered as a site for action selection and goal-directed behavior (Barron and Klein, 2016;  
1056 Fiore et al., 2015). A role of the CX in visual learning of spatial features has been shown in  
1057 various behavioral assays using fruit flies (Neuser et al., 2008; Ofstad et al., 2011; Kuntz et al.,  
1058 2012, 2017). The CX is also important for polarized light processing and navigation (Pfeiffer  
1059 and Homberg, 2014; Heinze, 2017).

1060 Using a genetic approach in *Drosophila melanogaster*, it was shown that the fan-shaped body  
1061 (FB), the largest component of the central complex, houses a memory trace for the pattern  
1062 parameter ‘elevation’, and a memory trace for ‘contour orientation’(Liu et al., 2006). A  
1063 following study showed that blocking the ellipsoid body, which is another substructure of the  
1064 CX connected to the FB, interferes with visual pattern memory (Pan et al., 2009).

1065 In *Cataglyphis noda* ants a comparison of neuroanatomical changes in the central complex  
1066 before and after a learning walks revealed that, under natural light conditions (UV light together  
1067 with a naturally changing polarization pattern), the CX undergoes a volume increase. While it  
1068 is not clear whether or not the neuroanatomical changes found in the CX are triggered by  
1069 appropriate sensory exposure or following the formation of spatial memory, those results still  
1070 suggest a potential involvement of the CX in visual learning (Grob et al., 2017). Honeybees  
1071 with inactivated CX (Fig.15) were unable to avoid a shock paired light despite not displaying  
1072 any motor deficit (Plath et al., 2017).

1073 The CX appears to play a role in visual learning in the context of navigation and spatial  
1074 orientation as is it involved in processing celestial cues like polarized light, which is crucial for  
1075 azimuthal orientation, but also in pattern recognition which is important to recognize  
1076 landmarks.

## 1077 The mushroom bodies

1078 The mushroom bodies contain 170,000 intrinsic neurons called Kenyon cells. At least three  
1079 sub-populations can be distinguished within these cells: small-type class I cells, large-type class  
1080 I cells and class II cells, more recently a third type called middle-type Kenyon cells was  
1081 identified (Kaneko et al., 2016).

1082 Quantifying the expression of Immediate Early Genes (IEGs) *kakusei*, Kiya et al. showed that  
1083 neural activity of a the small-type Kenyon cells is prominently increased in the brains of dancer  
1084 and forager honeybees. In contrast, the neural activity of the small-and large-type Kenyon cells  
1085 is increased in the brains of re-orienting workers, which memorize their hive location during  
1086 re-orienting flights. These findings demonstrate that the small-type Kenyon cell-preferential  
1087 activity is associated with foraging behavior, suggesting its involvement in information  
1088 integration during foraging flight, and thus potentially in visual learning (Kiya et al., 2007).  
1089 IEGs are gene that are transcribed transiently and rapidly in response to specific stimulations  
1090 inducing neural activity without de novo protein synthesis (Bahrami and Drabløs, 2016).  
1091 Thanks to those properties they offer a good proxy of neuronal activity, in mammals, *c-fos*,  
1092 *zif268* and *Arc* are regularly used as such during learning, memory and other forms of cellular  
1093 plasticity like as long-term potentiation (Minatohara et al., 2016; Gallo et al., 2018; He et al.,  
1094 2019). In insects, IEGs are used less often as the number of candidate genes serving this goal  
1095 is reduced and the reliable detection of their expression is sometimes difficult (Sommerlandt et  
1096 al., 2019). In their 2007 study, Kiya et al identified such a candidate IEG, *kakusei*, and  
1097 established a method to use it as a marker of neural activity. The *kakusei* transcript is localized  
1098 in the nuclei of neurons and does not encode an open reading frame, suggesting that it functions  
1099 as a non-coding nuclear RNA (Kiya et al., 2007).

1100 Mushroom bodies are divided into two types of structures: calyces and lobes. The dendrites of  
1101 Kenyon cells form the calyces and their axons form the pedunculus made up of two lobes

1102 (Mobbs and Young, 1982; Mobbs, 1984; Strausfeld et al., 2003). Calyces are the input region  
1103 for various types of sensory information while the lobes act as the output of the system. There  
1104 are two calyces per mushroom body: a median calyx and a lateral calyx. These two structures  
1105 have direct neuronal connections with the medulla and the lobula (Paulk et al., 2008). They are  
1106 made up of three sub-parts: the basal ring, the collar and the lip. The collar receives visual input  
1107 , the lip receives the olfactory inputs and the basal ring receives both (Strube-Bloss and Rössler,  
1108 2018). The collar region of the calyx is segregated into five layers that receive alternating input  
1109 from the dorsal or ventral medulla, respectively. A sixth, innermost layer of the collar receives  
1110 input from lobula neurons. In the basal ring region of the calyx, medulla neuron terminals are  
1111 restricted to a small, distal part. Lobula neurons are more prominent in the basal ring, where  
1112 they terminate in its outer half (Ehmer and Gronenberg, 2002).

1113 The lobes of mushroom bodies are divided into two parts: vertical lobe and median lobe (Ito et  
1114 al., 2014a), which are interconnected. Information from the calyces joins other structures of the  
1115 bee brain by passing through these two lobes (Menzel, 1999).

1116 The mushroom bodies have been shown to be involved in both olfactory and visual learning  
1117 (Komischke et al., 2005; Devaud et al., 2015b; Plath et al., 2017) although their implication in  
1118 visual learning is less clear. Using the APIS assay described earlier, Plath et al. studied learning  
1119 performance of bees in which different lobes of the mushroom bodies had been transiently  
1120 inactivated by microinjection of the reversible anesthetic procaine. Control bees learned to  
1121 escape the shock-paired light field and to spend more time in the safe light field after a few  
1122 trials. When medial lobe neurons of the mushroom bodies were silenced, bees were no longer  
1123 able to associate one light field with shock. By contrast, silencing of one collar region of the  
1124 mushroom body calyx (Fig15.C) did not alter behavior in the learning assay in comparison to  
1125 control treatment (Plath et al., 2017). Those results are coherent with previous olfactory

1126 experiments that showed that inactivation of mushroom body lobes via the injection of  
 1127 cholinergic antagonist disrupts memory retrieval (Lozano et al., 2001).

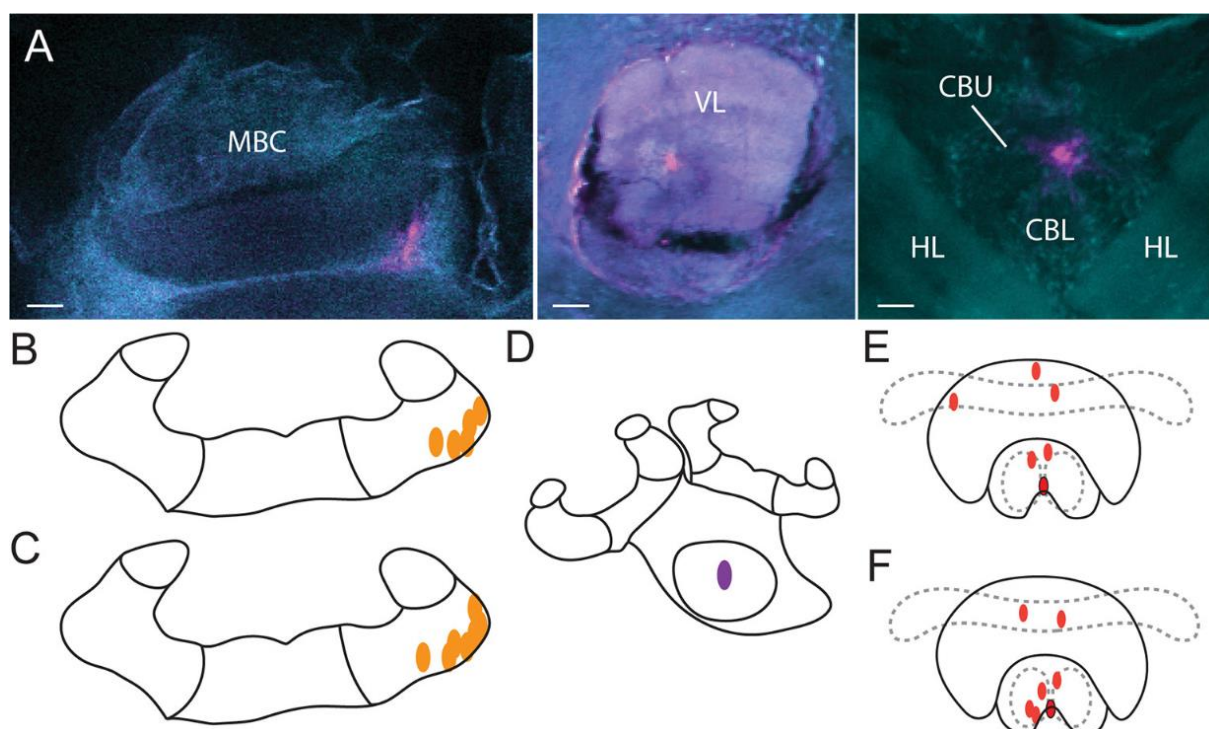

1128

1129 **Figure 15. Procaine injection sites.** (A) Alexa dye injections are shown in magenta (false  
 1130 color) in the MBC (left), VL (middle) and the CX (right). A DAPI-counterstain and auto-  
 1131 fluorescence of the brain tissue (false colored in cyan) allowed us to identify brain neuropils.  
 1132 Orientation of all three scans was aligned with rostral (neuraxis) facing upwards. Injections of  
 1133 vehicle (B) and of procaine solution (C) into the MBC. Injections into the VL (D). Injections  
 1134 of vehicle (E) and of procaine solution (F) into the central body (red dots) and injections located  
 1135 at the border of the lower division of the central body with spread into the noduli (red dots with  
 1136 black border). MBC, mushroom body calyces; VL, ventral lobes; HL, horizontal lobes; CBU,  
 1137 upper division of the central body; CBL, lower division of the central body; Scale bar = 30  $\mu\text{m}$ .  
 1138 Taken from Plath et al., 2017.

1139 Similarly, Kamhi et al. studied the effect of procaine inactivation of the vertical lobes (VL) of the  
 1140 mushroom bodies on view-based navigation in ants (*Myrmecia midas*). Experienced foragers  
 1141 were collected, treated, and released in their familiar environment where their behavior was  
 1142 documented. Animals with procaine-inactivated VLs had tortuous paths and were unable to  
 1143 find their nest, whereas control ants were well directed and were the most successful at returning  
 1144 home. Untreated animals walked faster when their gaze was directed toward home, and this

1145 behavior was eliminated by anesthetizing the VL region (Kamhi et al., 2020), thus showing that  
1146 the mushroom body vertical lobes are necessary for retrieving visual memories.

1147 Contrary to Plath et al. results on calyces, in an ant species (*Formica rufa*) lesions of the  
1148 mushroom body calyces rendered the ants unable to go toward a previously trained feeder  
1149 location (Buehlmann et al., 2020). The discrepancy between those results might be explained  
1150 by the fact that Plath et al only silenced one collar region of the calyces which might have been  
1151 compensated by the other three collars. More results suggest that the calyces play a part in  
1152 visual learning, Li et al found a correlation between success in a visual discrimination task and  
1153 microglomeruli density in the collar region of the MB (Li et al., 2017).

1154 Moreover, when bees are trained in the ICARUS setup (described earlier) to inhibit their  
1155 spontaneous phototaxis by pairing the attracting light with an electric shock (Marchal et al.,  
1156 2019), learning induced an increase in the dopaminergic receptor gene *Amdop1* in the calyces  
1157 of the mushroom bodies, consistently with the role of dopaminergic signaling for electric-shock  
1158 representation in this region of the brain (Unoki et al., 2005; Vergoz et al., 2007; Mizunami et  
1159 al., 2009; Agarwal et al., 2011; Tedjakumala et al., 2013).

1160 In *Drosophila melanogaster* it was found that inhibition from a single pair of giant GABAergic  
1161 neurons, the anterior paired lateral (APL) neurons, onto the mushroom bodies (MBs) selectively  
1162 facilitates behavioral flexibility during visual reversal learning. Indeed, acute disruption of the  
1163 APL–MB circuit was sufficient to impair visual reversal learning, while flies with dysfunctional  
1164 APL–MB circuit performed normally in simple forms of visual learning (Ren et al., 2012).

1165 In honeybees inhibition of the MBs was also shown to specifically impair olfactory reversal  
1166 learning (Devaud et al., 2007; Boitard et al., 2015). GABAergic inhibitory feedback on the MBs  
1167 is provided by A3v and A3d neurons (Bicker et al., 1985; Gronenberg, 1987; Grünewald, 1999).  
1168 Both innervate the output region of the MBs (the lobes) but A3v neurons also feedback onto  
1169 the input region (the calyces). A3 neurons have been shown to change their response to

1170 rewarded and unrewarded visual stimulus after conditioning (Zwaka et al., 2019). And similarly  
1171 to APL neuron in *Drosophila*, it was shown that inhibition of GABAergic signaling into the  
1172 MB calyces impairs olfactory reversal learning, but leaves intact the capacity to perform  
1173 elemental olfactory conditioning (Boitard et al., 2015; Devaud et al., 2015b). However,  
1174 inhibition of GABAergic signaling into the lobes instead of the calyces had no effect on reversal  
1175 learning (Boitard et al., 2015). Even though these experiments were conducted with olfactory  
1176 conditioning, it is reasonable to expect similar results for vision as centralization of similar  
1177 brain functions spares the cost of maintaining similar circuit motifs in different brain areas.  
1178 Indeed, in *Drosophila* it was found that the same subsets of dopaminergic MB neurons drive  
1179 formation of both olfactory and visual memories (Vogt et al., 2014). Furthermore, distinct yet  
1180 partially overlapping subsets of mushroom body intrinsic neurons were shown to be required  
1181 for visual and olfactory memories (Vogt et al., 2014). This convergence of different modality  
1182 might be an evolutionary conserved design of information processing as such converging inputs  
1183 of different stimuli into a multisensory area have even been described in humans (Beauchamp  
1184 et al., 2008). GABAergic feedback between the lobes (output) and calyces (input) was also  
1185 shown to be involved in visual context learning and neural error responses following erroneous  
1186 behavior (Filla and Menzel, 2015).

1187 Thus the MBs appear to be major integration centers in the honeybee's brain, involved in  
1188 multiple forms of learning from simple association to more complex reversal learning.

### 1189 **Whole circuit mechanisms**

1190 Despite the consequent body of evidence pointing to the MBs as a center for learning and  
1191 memory, they are not the only structure of the visual system involved in memory formation. A  
1192 recent study quantifying gene expression kinetic in the brains of honeybees after aversive visual  
1193 conditioning showed a parallel activation of the optic lobes and the MBs following a similar

1194 time course (Avalos et al., 2021). This suggest that sensory neuropils are also involved in  
1195 associative learning.

1196 In order to explore the implication of the peripheral processing stages and high-order integration  
1197 centers of the insect brain in visual learning, Yilmaz et al. quantified the volumetric changes in  
1198 different neuropils directly after color conditioning and, 3 days later, after the establishment of  
1199 long-term memory (LTM), in *Camponotus blandus* ants. They found a volume increase of the  
1200 OLs, the AOTu, and the fan-shaped body (FB) and protocerebral bridge (PB) which are neuropil  
1201 of the CX, after color learning and LTM formation. They did not find any specific structural  
1202 change in the MBs (Yilmaz et al., 2019), which is coherent with findings in honeybees where  
1203 no changes of the number of presynaptic buttons in the collar was found after fine color  
1204 discrimination (Sommerlandt et al., 2016). However, those results could be explained by the  
1205 absence of memory formation in the tested bees as the authors did not test for long term  
1206 memory. Yilmaz et al. results are also coherent with results mentioned earlier where a role of  
1207 the VL but not the collar was suggested for aversive color learning after procaine injections in  
1208 the respective areas (Plath et al., 2017).

1209 A volume increase in the OLs might affect processing of color information at the level of color  
1210 opponency, the volume of the OLs increased significantly after LTM formation, which may  
1211 increase and strengthen the excitatory neuronal connections that are relevant for discrimination  
1212 behavior (Yang et al., 2004). These results are coherent with the parallel activation of the OLs  
1213 with the MB found in honeybees during visual learning (Avalos et al., 2021). Changes in the  
1214 volume of the FB, suggest it is a potential region in the CX involved in visual memory formation  
1215 after associative color learning. This is consistent with previous findings in *Drosophila* that  
1216 implicate the FB in visual pattern memory formation (Liu et al., 2006; Pan et al., 2009).The  
1217 volume increase of the AOTu found in ants is coherent with results in bees and locusts, where

1218 the upper unit of the AOTu has been implicated in the processing of chromatic information  
1219 (Pfeiffer and Homberg, 2007; Mota et al., 2013, 2016).

1220 Thus the MBs appear to be the best candidate for further exploration of the neural basis of visual  
1221 learning as they have been shown to play a role in both simple associative conditioning (Plath  
1222 et al., 2017) and more complex reversal learning (Devaud et al., 2007; Ren et al., 2012).  
1223 However, we can also see that learning actually involves the whole system, from volume  
1224 modification measured in the optic lobes (Yilmaz et al., 2019) to impaired response to learn  
1225 stimulus by silencing the CX (Plath et al., 2017). As such whole brain analysis of the effect of  
1226 visual learning on the activation of those different structure, using for example immediate early  
1227 gene like *kakusei* (Kiya et al., 2007) as markers, appears like a promising path.

1228

1229 **References**

- 1230 Abel, R., Rybak, J., Menzel, R., 2001. Structure and response patterns of olfactory interneurons in the  
1231 honeybee, *Apis mellifera*. *J. Comp. Neurol.* 437, 363–383. <https://doi.org/10.1002/cne.1289>
- 1232 Agarwal, M., Giannoni Guzmán, M., Morales-Matos, C., Del Valle Díaz, R.A., Abramson, C.I., Giray, T.,  
1233 2011. Dopamine and Octopamine Influence Avoidance Learning of Honey Bees in a Place  
1234 Preference Assay. *PLoS ONE* 6. <https://doi.org/10.1371/journal.pone.0025371>
- 1235 Avalos, A., Traniello, I.M., Pérez Claudio, E., Giray, T., 2021. Parallel mechanisms of visual memory  
1236 formation across distinct regions of the honey bee brain. *J. Exp. Biol.* 224, jeb242292.  
1237 <https://doi.org/10.1242/jeb.242292>
- 1238 Avarguès-Weber, A., de Brito Sanchez, M.G., Giurfa, M., Dyer, A.G., 2010. Aversive Reinforcement  
1239 Improves Visual Discrimination Learning in Free-Flying Honeybees. *PLoS ONE* 5.  
1240 <https://doi.org/10.1371/journal.pone.0015370>
- 1241 Avarguès-Weber, A., Deisig, N., Giurfa, M., 2011a. Visual Cognition in Social Insects. *Annu. Rev.*  
1242 *Entomol.* 56, 423–443. <https://doi.org/10.1146/annurev-ento-120709-144855>
- 1243 Avarguès-Weber, A., Dyer, A.G., Combe, M., Giurfa, M., 2012a. Simultaneous mastering of two  
1244 abstract concepts by the miniature brain of bees. *Proc. Natl. Acad. Sci. U. S. A.* 109, 7481–  
1245 7486. <https://doi.org/10.1073/pnas.1202576109>
- 1246 Avarguès-Weber, A., Dyer, A.G., Giurfa, M., 2011b. Conceptualization of above and below  
1247 relationships by an insect. *Proc. R. Soc. B Biol. Sci.* 278, 898–905.  
1248 <https://doi.org/10.1098/rspb.2010.1891>
- 1249 Avarguès-Weber, A., Giurfa, M., 2013. Conceptual learning by miniature brains. *Proc. Biol. Sci.* 280,  
1250 20131907. <https://doi.org/10.1098/rspb.2013.1907>
- 1251 Avarguès-Weber, A., Mota, T., 2016. Advances and limitations of visual conditioning protocols in  
1252 harnessed bees. *J. Physiol.-Paris, SI: Neuroethology* 2016 110, 107–118.  
1253 <https://doi.org/10.1016/j.jphysparis.2016.12.006>
- 1254 Avarguès-Weber, A., Mota, T., Giurfa, M., 2012b. New vistas on honey bee vision. *Apidologie* 43,  
1255 244–268. <https://doi.org/10.1007/s13592-012-0124-2>
- 1256 Backhaus, W., 1992. Color vision in honeybees. *Neurosci. Biobehav. Rev.* 16, 1–12.  
1257 [https://doi.org/10.1016/S0149-7634\(05\)80045-4](https://doi.org/10.1016/S0149-7634(05)80045-4)
- 1258 Bahrami, S., Drabløs, F., 2016. Gene regulation in the immediate-early response process. *Adv. Biol.*  
1259 *Regul.* 62, 37–49. <https://doi.org/10.1016/j.jbior.2016.05.001>
- 1260 Baird, E., Boeddeker, N., Srinivasan, M.V., 2021. The effect of optic flow cues on honeybee flight  
1261 control in wind. *Proc. R. Soc. B Biol. Sci.* 288, 20203051.  
1262 <https://doi.org/10.1098/rspb.2020.3051>
- 1263 Baird, E., Dacke, M., 2012. Visual flight control in naturalistic and artificial environments. *J. Comp.*  
1264 *Physiol. A* 198, 869–876. <https://doi.org/10.1007/s00359-012-0757-7>
- 1265 Baird, E., Srinivasan, M.V., Zhang, S., Lamont, R., Cowling, A., 2006. Visual Control of Flight Speed and  
1266 Height in the Honeybee, in: Nolfi, S., Baldassarre, G., Calabretta, R., Hallam, J.C.T., Marocco,  
1267 D., Meyer, J.-A., Miglino, O., Parisi, D. (Eds.), *From Animals to Animats 9, Lecture Notes in*  
1268 *Computer Science*. Springer, Berlin, Heidelberg, pp. 40–51.  
1269 [https://doi.org/10.1007/11840541\\_4](https://doi.org/10.1007/11840541_4)
- 1270 Balamurali, G.S., Somanathan, H., Hempel de Ibarra, N., 2015. Motion cues improve the performance  
1271 of harnessed bees in a colour learning task. *J. Comp. Physiol. A* 201, 505–511.  
1272 <https://doi.org/10.1007/s00359-015-0994-7>
- 1273 Barron, A.B., Klein, C., 2016. What insects can tell us about the origins of consciousness. *Proc. Natl.*  
1274 *Acad. Sci.* 113, 4900–4908. <https://doi.org/10.1073/pnas.1520084113>
- 1275 Beauchamp, M.S., Yasar, N.E., Frye, R.E., Ro, T., 2008. Touch, sound and vision in human superior  
1276 temporal sulcus. *NeuroImage* 41, 1011–1020.  
1277 <https://doi.org/10.1016/j.neuroimage.2008.03.015>

- 1278 Bestea, L., Briard, E., Carcaud, J., Sandoz, J.-C., Velarde, R., Giurfa, M., Maria Gabriela, de B.S., 2022.  
1279 The short neuropeptide F (sNPF) promotes the formation of appetitive visual memories in  
1280 honey bees. *Biol. Lett.* (in press).
- 1281 Bicker, G., Schäfer, S., Kingan, T.G., 1985. Mushroom body feedback interneurons in the honeybee  
1282 show GABA-like immunoreactivity. *Brain Res.* 360, 394–397. [https://doi.org/10.1016/0006-8993\(85\)91262-4](https://doi.org/10.1016/0006-8993(85)91262-4)
- 1284 Bicker, G., Schäfer, S., Rehder, V., 1987. Chemical Neuroanatomy of the Honeybee Brain, in: Menzel,  
1285 R., Mercer, A. (Eds.), *Neurobiology and Behavior of Honeybees*. Springer, Berlin, Heidelberg,  
1286 pp. 202–224. [https://doi.org/10.1007/978-3-642-71496-2\\_17](https://doi.org/10.1007/978-3-642-71496-2_17)
- 1287 Bitterman, M.E., Menzel, R., Fietz, A., Schäfer, S., 1983. Classical conditioning of proboscis extension  
1288 in honeybees (*Apis mellifera*). *J. Comp. Psychol. Wash. DC* 1983 97, 107–119.
- 1289 Boitard, C., Devaud, J.-M., Isabel, G., Giurfa, M., 2015. GABAergic feedback signaling into the calyces  
1290 of the mushroom bodies enables olfactory reversal learning in honey bees. *Front. Behav.*  
1291 *Neurosci.* 9, 198. <https://doi.org/10.3389/fnbeh.2015.00198>
- 1292 Breed, M.D., Guzmán-Novoa, E., Hunt, G.J. 3, 2004. Defensive behavior of honey bees: organization,  
1293 genetics, and comparisons with other bees. *Annu. Rev. Entomol.* 49, 271–298.  
1294 <https://doi.org/10.1146/annurev.ento.49.061802.123155>
- 1295 Buatois, A., Flumian, C., Schultheiss, P., Avarguès-Weber, A., Giurfa, M., 2018. Transfer of Visual  
1296 Learning Between a Virtual and a Real Environment in Honey Bees: The Role of Active Vision.  
1297 *Front. Behav. Neurosci.* 12, 139. <https://doi.org/10.3389/fnbeh.2018.00139>
- 1298 Buatois, A., Laroche, L., Lafon, G., Avarguès-Weber, A., Giurfa, M., 2020. Higher-order discrimination  
1299 learning by honeybees in a virtual environment. *Eur. J. Neurosci.* 51, 681–694.  
1300 <https://doi.org/10.1111/ejn.14633>
- 1301 Buatois, A., Pichot, C., Schultheiss, P., Sandoz, J.-C., Lazzari, C.R., Chittka, L., Avarguès-Weber, A.,  
1302 Giurfa, M., 2017. Associative visual learning by tethered bees in a controlled visual  
1303 environment. *Sci. Rep.* 7. <https://doi.org/10.1038/s41598-017-12631-w>
- 1304 Buehlmann, C., Wozniak, B., Goulard, R., Webb, B., Graham, P., Niven, J.E., 2020. Mushroom Bodies  
1305 Are Required for Learned Visual Navigation, but Not for Innate Visual Behavior, in *Ants. Curr.*  
1306 *Biol. CB* 30, 3438–3443.e2. <https://doi.org/10.1016/j.cub.2020.07.013>
- 1307 Carcaud, J., Giurfa, M., Sandoz, J.C., 2016. Parallel Olfactory Processing in the Honey Bee Brain: Odor  
1308 Learning and Generalization under Selective Lesion of a Projection Neuron Tract. *Front.*  
1309 *Integr. Neurosci.* 9. <https://doi.org/10.3389/fnint.2015.00075>
- 1310 Chittka, L., Geiger, K., 1995. Can honey bees count landmarks? *Anim. Behav.* 49, 159–164.  
1311 [https://doi.org/10.1016/0003-3472\(95\)80163-4](https://doi.org/10.1016/0003-3472(95)80163-4)
- 1312 Chittka, L., Thomson, J., Waser, N., 1999. Flower Constancy, Insect Psychology, and Plant Evolution.  
1313 *Naturwissenschaften* 86, 361–377. <https://doi.org/10.1007/s001140050636>
- 1314 Dacke, M., Srinivasan, M.V., 2008. Evidence for counting in insects. *Anim. Cogn.* 11, 683–689.  
1315 <https://doi.org/10.1007/s10071-008-0159-y>
- 1316 Dahmen, H., Wahl, V.L., Pfeffer, S.E., Mallot, H.A., Wittlinger, M., 2017. Naturalistic path integration  
1317 of *Cataglyphis* desert ants on an air-cushioned lightweight spherical treadmill. *J. Exp. Biol.*  
1318 220, 634–644. <https://doi.org/10.1242/jeb.148213>
- 1319 D’Eath, R.B., 1998. Can video images imitate real stimuli in animal behaviour experiments? *Biol. Rev.*  
1320 *Camb. Philos. Soc.* 73, 267–292. <https://doi.org/10.1017/S0006323198005179>
- 1321 Devaud, J.-M., Blunk, A., Poduffall, J., Giurfa, M., Grünewald, B., 2007. Using local anaesthetics to  
1322 block neuronal activity and map specific learning tasks to the mushroom bodies of an insect  
1323 brain. *Eur. J. Neurosci.* 26, 3193–3206. <https://doi.org/10.1111/j.1460-9568.2007.05904.x>
- 1324 Devaud, J.-M., Papouin, T., Carcaud, J., Sandoz, J.-C., Grünewald, B., Giurfa, M., 2015a. Neural  
1325 substrate for higher-order learning in an insect: Mushroom bodies are necessary for  
1326 configural discriminations. *Proc. Natl. Acad. Sci. U. S. A.* 112, E5854–E5862.  
1327 <https://doi.org/10.1073/pnas.1508422112>
- 1328 Devaud, J.-M., Papouin, T., Carcaud, J., Sandoz, J.-C., Grünewald, B., Giurfa, M., 2015b. Neural  
1329 substrate for higher-order learning in an insect: Mushroom bodies are necessary for

- 1330 configural discriminations. *Proc. Natl. Acad. Sci. U. S. A.* 112, E5854–E5862.  
1331 <https://doi.org/10.1073/pnas.1508422112>
- 1332 Dobrin, S.E., Fahrbach, S.E., 2012. Visual Associative Learning in Restrained Honey Bees with Intact  
1333 Antennae. *PLOS ONE* 7, e37666. <https://doi.org/10.1371/journal.pone.0037666>
- 1334 Doumas, L.A.A., Hummel, J.E., Sandhofer, C.M., 2008. A theory of the discovery and predication of  
1335 relational concepts. *Psychol. Rev.* 115, 1–43. <https://doi.org/10.1037/0033-295X.115.1.1>
- 1336 Dyer, A.G., 2012. The mysterious cognitive abilities of bees: why models of visual processing need to  
1337 consider experience and individual differences in animal performance. *J. Exp. Biol.* 215, 387–  
1338 395. <https://doi.org/10.1242/jeb.038190>
- 1339 Dyer, A.G., Neumeyer, C., 2005. Simultaneous and successive colour discrimination in the honeybee  
1340 (*Apis mellifera*). *J. Comp. Physiol. A* 191, 547–557. <https://doi.org/10.1007/s00359-005-0622-z>
- 1341
- 1342 Dyer, A.G., Paulk, A.C., Reser, D.H., 2011. Colour processing in complex environments: insights from  
1343 the visual system of bees. *Proc. R. Soc. B Biol. Sci.* 278, 952–959.  
1344 <https://doi.org/10.1098/rspb.2010.2412>
- 1345 Ehmer, B., Gronenberg, W., 2002. Segregation of visual input to the mushroom bodies in the  
1346 honeybee (*Apis mellifera*). *J. Comp. Neurol.* 451, 362–373.  
1347 <https://doi.org/10.1002/cne.10355>
- 1348 Felsenberg, J., Gehring, K.B., Antemann, V., Eisenhardt, D., 2011. Behavioural Pharmacology in  
1349 Classical Conditioning of the Proboscis Extension Response in Honeybees (*Apis mellifera*).  
1350 *JoVE J. Vis. Exp.* e2282–e2282. <https://doi.org/10.3791/2282>
- 1351 Filla, I., Menzel, R., 2015. Mushroom body extrinsic neurons in the honeybee (*Apis mellifera*) brain  
1352 integrate context and cue values upon attentional stimulus selection. *J. Neurophysiol.* 114,  
1353 2005–2014. <https://doi.org/10.1152/jn.00776.2014>
- 1354 Fiore, V.G., Dolan, R.J., Strausfeld, N.J., Hirth, F., 2015. Evolutionarily conserved mechanisms for the  
1355 selection and maintenance of behavioural activity. *Philos. Trans. R. Soc. B Biol. Sci.* 370,  
1356 20150053. <https://doi.org/10.1098/rstb.2015.0053>
- 1357 Fleishman, L.J., Endler, J.A., 2000. Some comments on visual perception and the use of video  
1358 playback in animal behavior studies. *Acta Ethologica* 3, 15–27.
- 1359 Fleishman, L.J., McClintock, W.J., D'Eath, R.B., Brainard, D.H., Endler, J.A., 1998. Colour perception  
1360 and the use of video playback experiments in animal behaviour. *Anim. Behav.* 56, 1035–  
1361 1040. <https://doi.org/10.1006/anbe.1998.0894>
- 1362 Frasnelli, E., Hempel de Ibarra, N., Stewart, F.J., 2018. The Dominant Role of Visual Motion Cues in  
1363 Bumblebee Flight Control Revealed Through Virtual Reality. *Front. Physiol.* 9.  
1364 <https://doi.org/10.3389/fphys.2018.01038>
- 1365 Frings, H., 1944. The loci of olfactory end-organs in the honey-bee, *Apis mellifera* Linn. *J. Exp. Zool.*  
1366 97, 123–134. <https://doi.org/10.1002/jez.1400970203>
- 1367 Frings, H., Frings, M., 1949. The Loci of Contact Chemoreceptors in Insects. A Review with New  
1368 Evidence. *Am. Midl. Nat.* 41, 602–658. <https://doi.org/10.2307/2421776>
- 1369 Frisch, K. von, 1886-, Frisch, K. von, 1886-, 1967. *Dance language and orientation of bees.* Harvard  
1370 University Press.
- 1371 Gallo, F.T., Katche, C., Morici, J.F., Medina, J.H., Weisstaub, N.V., 2018. Immediate Early Genes,  
1372 Memory and Psychiatric Disorders: Focus on c-Fos, Egr1 and Arc. *Front. Behav. Neurosci.* 12,  
1373 79. <https://doi.org/10.3389/fnbeh.2018.00079>
- 1374 Giurfa, M., 2007. Behavioral and neural analysis of associative learning in the honeybee: a taste from  
1375 the magic well. *J. Comp. Physiol. A Neuroethol. Sens. Neural. Behav. Physiol.* 193, 801–824.  
1376 <https://doi.org/10.1007/s00359-007-0235-9>
- 1377 Giurfa, M., 2004. Conditioning procedure and color discrimination in the honeybee *Apis mellifera*.  
1378 *Sci. Nat.* 5, 228–231. <https://doi.org/10.1007/s00114-004-0530-z>
- 1379 Giurfa, Martin, Eichmann, B., Menzel, R., 1996. Symmetry perception in an insect. *Nature* 382, 458–  
1380 461. <https://doi.org/10.1038/382458a0>

- 1381 Giurfa, M., Menzel, R., 1997. Insect visual perception: complex abilities of simple nervous systems.  
1382 *Curr. Opin. Neurobiol.* 7, 505–513. [https://doi.org/10.1016/S0959-4388\(97\)80030-X](https://doi.org/10.1016/S0959-4388(97)80030-X)
- 1383 Giurfa, M., Sandoz, J.-C., 2012. Invertebrate learning and memory: Fifty years of olfactory  
1384 conditioning of the proboscis extension response in honeybees. *Learn. Mem.* 19, 54–66.  
1385 <https://doi.org/10.1101/lm.024711.111>
- 1386 Giurfa, M., Vorobyev, M., Kevan, P., Menzel, R., 1996. Detection of coloured stimuli by honeybees:  
1387 Minimum visual angles and receptor specific contrasts. *J. Comp. Physiol. [A]* 178, 699–709.  
1388 <https://doi.org/10.1007/BF00227381>
- 1389 Giurfa, M., Zhang, S., Jenett, A., Menzel, R., Srinivasan, M.V., 2001. The concepts of ‘sameness’ and  
1390 ‘difference’ in an insect. *Nature* 410, 930–933. <https://doi.org/10.1038/35073582>
- 1391 Götz, K.G., 1964. Optomotorische Untersuchung des visuellen systems einiger Augenmutanten der  
1392 Fruchtfliege *Drosophila*. *Kybernetik* 2, 77–92. <https://doi.org/10.1007/BF00288561>
- 1393 Grant, V., 1951. The fertilization of flowers. *Sci. Am.* 184, 52–57.
- 1394 Grob, R., Fleischmann, P.N., Grübel, K., Wehner, R., Rössler, W., 2017. The Role of Celestial Compass  
1395 Information in *Cataglyphis* Ants during Learning Walks and for Neuroplasticity in the Central  
1396 Complex and Mushroom Bodies. *Front. Behav. Neurosci.* 11, 226.  
1397 <https://doi.org/10.3389/fnbeh.2017.00226>
- 1398 Gronenberg, W., 1987. Anatomical and physiological properties of feedback neurons of the  
1399 mushroom bodies in the bee brain. *Exp. Biol.* 46, 115–125.
- 1400 Gronenberg, W., 1986. Physiological and anatomical properties of optical input-fibres to the  
1401 mushroom body in the bee brain. *J. Insect Physiol.* 32, 695–704.  
1402 [https://doi.org/10.1016/0022-1910\(86\)90111-3](https://doi.org/10.1016/0022-1910(86)90111-3)
- 1403 Gross, H.J., Pahl, M., Si, A., Zhu, H., Tautz, J., Zhang, S., 2009. Number-Based Visual Generalisation in  
1404 the Honeybee. *PLoS ONE* 4, e4263. <https://doi.org/10.1371/journal.pone.0004263>
- 1405 Grünewald, B., 1999. Physiological properties and response modulations of mushroom body  
1406 feedback neurons during olfactory learning in the honeybee, *Apis mellifera*. *J. Comp. Physiol.*  
1407 *A* 185, 565–576. <https://doi.org/10.1007/s003590050417>
- 1408 Guerrieri, F., Schubert, M., Sandoz, J.-C., Giurfa, M., 2005. Perceptual and Neural Olfactory Similarity  
1409 in Honeybees. *PLOS Biol.* 3, e60. <https://doi.org/10.1371/journal.pbio.0030060>
- 1410 Haehnel, M., Menzel, R., 2010. Sensory representation and learning-related plasticity in mushroom  
1411 body extrinsic feedback neurons of the protocerebral tract. *Front. Syst. Neurosci.* 4, 161.  
1412 <https://doi.org/10.3389/fnsys.2010.00161>
- 1413 Halford, G.S., Wilson, W.H., Phillips, S., 2010. Relational knowledge: the foundation of higher  
1414 cognition. *Trends Cogn. Sci.* 14, 497–505. <https://doi.org/10.1016/j.tics.2010.08.005>
- 1415 Hassenstein, B., 1951. Ommatidienraster und afferente Bewegungsintegration. *Z. Für Vgl. Physiol.* 33,  
1416 301–326. <https://doi.org/10.1007/BF00339334>
- 1417 Hassenstein, B., 1950. Wandernde geometrische Interferenzfiguren im Insektenauge.  
1418 *Naturwissenschaften* 37, 45–46. <https://doi.org/10.1007/BF00645369>
- 1419 Hateren, J.H. van, Srinivasan, M.V., Wait, P.B., 1990. Pattern recognition in bees: orientation  
1420 discrimination. *J. Comp. Physiol. A* 167, 649–654.
- 1421 He, Q., Wang, J., Hu, H., 2019. Illuminating the Activated Brain: Emerging Activity-Dependent Tools to  
1422 Capture and Control Functional Neural Circuits. *Neurosci. Bull.* 35, 369–377.  
1423 <https://doi.org/10.1007/s12264-018-0291-x>
- 1424 Heinze, S., 2017. Unraveling the neural basis of insect navigation. *Curr. Opin. Insect Sci.,*  
1425 *Neuroscience \* Pheromones* 24, 58–67. <https://doi.org/10.1016/j.cois.2017.09.001>
- 1426 Hertel, H., 1980. Chromatic properties of identified interneurons in the optic lobes of the bee. *J.*  
1427 *Comp. Physiol.* 137, 215–231. <https://doi.org/10.1007/BF00657117>
- 1428 Hertel, H., Maronde, U., 1987. The physiology and morphology of centrally projecting visual  
1429 interneurons in the honey bee brain. *J Exp Biol* 133, 301–315.
- 1430 Hertel, H., Schafer, S., Maronde, U., 1987. The physiology and morphology of centrally projecting  
1431 visual interneurons in the honeybee brain. *J Exp Biol* 133, 283–300.

- 1432 Hess, C., 1911. Experimentelle Untersuchungen zur vergleichenden Physiologie des Gesichtssinnes.  
1433 Pflüg. Arch. Für Gesamte Physiol. Menschen Tiere 142, 405–446.  
1434 <https://doi.org/10.1007/BF01680657>
- 1435 Hori, S., Takeuchi, H., Arikawa, K., Kinoshita, M., Ichikawa, N., Sasaki, M., Kubo, T., 2006. Associative  
1436 visual learning, color discrimination, and chromatic adaptation in the harnessed honeybee  
1437 *Apis mellifera* L. J. Comp. Physiol. A 192, 691–700. [https://doi.org/10.1007/s00359-005-](https://doi.org/10.1007/s00359-005-0091-4)  
1438 0091-4
- 1439 Hori, S., Takeuchi, H., Kubo, T., 2007. Associative learning and discrimination of motion cues in the  
1440 harnessed honeybee *Apis mellifera* L. J. Comp. Physiol. A 193, 825–833.  
1441 <https://doi.org/10.1007/s00359-007-0234-x>
- 1442 Horridge, A., 2009. Generalization in visual recognition by the honeybee (*Apis mellifera*): A review  
1443 and explanation. J. Insect Physiol. 55, 499–511.  
1444 <https://doi.org/10.1016/j.jinsphys.2009.03.006>
- 1445 Horridge, A., 2000. Seven experiments on pattern vision of the honeybee, with a model. Vision Res.  
1446 40, 2589–2603. [https://doi.org/10.1016/S0042-6989\(00\)00096-1](https://doi.org/10.1016/S0042-6989(00)00096-1)
- 1447 Horridge, G.A., 1987. The evolution of visual processing and the construction of seeing systems. Proc.  
1448 R. Soc. Lond. B Biol. Sci. 230, 279–292. <https://doi.org/10.1098/rspb.1987.0020>
- 1449 Howard, S.R., Avarguès-Weber, A., Garcia, J.E., Greentree, A.D., Dyer, A.G., 2019. Numerical cognition  
1450 in honeybees enables addition and subtraction. Sci. Adv. 5, eaav0961.  
1451 <https://doi.org/10.1126/sciadv.aav0961>
- 1452 Ito, K., Shinomiya, K., Ito, M., Armstrong, J.D., Boyan, G., Hartenstein, V., Harzsch, S., Heisenberg, M.,  
1453 Homberg, U., Jenett, A., Keshishian, H., Restifo, L.L., Rössler, W., Simpson, J.H., Strausfeld,  
1454 N.J., Strauss, R., Vosshall, L.B., 2014a. A Systematic Nomenclature for the Insect Brain.  
1455 Neuron 81, 755–765. <https://doi.org/10.1016/j.neuron.2013.12.017>
- 1456 Ito, K., Shinomiya, K., Ito, M., Armstrong, J.D., Boyan, G., Hartenstein, V., Harzsch, S., Heisenberg, M.,  
1457 Homberg, U., Jenett, A., Keshishian, H., Restifo, L.L., Rössler, W., Simpson, J.H., Strausfeld,  
1458 N.J., Strauss, R., Vosshall, L.B., Insect Brain Name Working Group, 2014b. A systematic  
1459 nomenclature for the insect brain. Neuron 81, 755–765.  
1460 <https://doi.org/10.1016/j.neuron.2013.12.017>
- 1461 Jernigan, C.M., Roubik, D.W., Wcislo, W.T., Riveros, A.J., 2014. Color-dependent learning in restrained  
1462 Africanized honey bees. J. Exp. Biol. 217, 337–343. <https://doi.org/10.1242/jeb.091355>
- 1463 Kai, K., Okada, J., 2013. Characterization of Locomotor-Related Spike Activity in Protocerebrum of  
1464 Freely Walking Cricket. Zoolog. Sci. 30, 591–601. <https://doi.org/10.2108/zsj.30.591>
- 1465 Kamhi, J.F., Barron, A.B., Narendra, A., 2020. Vertical Lobes of the Mushroom Bodies Are Essential for  
1466 View-Based Navigation in Australian *Myrmecia* Ants. Curr. Biol. CB 30, 3432-3437.e3.  
1467 <https://doi.org/10.1016/j.cub.2020.06.030>
- 1468 Kaneko, K., Suenami, S., Kubo, T., 2016. Gene expression profiles and neural activities of Kenyon cell  
1469 subtypes in the honeybee brain: identification of novel ‘middle-type’ Kenyon cells. Zool. Lett.  
1470 2, 14. <https://doi.org/10.1186/s40851-016-0051-6>
- 1471 Kehoe, E.J., Graham, P., 1988. Summation and configuration: Stimulus compounding and negative  
1472 patterning in the rabbit. J. Exp. Psychol. Anim. Behav. Process. 14, 320–333.  
1473 <https://doi.org/10.1037/0097-7403.14.3.320>
- 1474 Kien, J., Menzel, R., 1977. Chromatic properties of interneurons in the optic lobes of the bee. J.  
1475 Comp. Physiol. 113, 17–34. <https://doi.org/10.1007/BF00610451>
- 1476 Kirchner, W.H., Srinivasan, M.V., 1989. Freely flying honeybees use image motion to estimate object  
1477 distance. Naturwissenschaften 76, 281–282. <https://doi.org/10.1007/BF00368643>
- 1478 Kirkerud, N., Wehmann, H., Galizia, C., Gustav, D., 2013. APIS—a novel approach for conditioning  
1479 honey bees. Front. Behav. Neurosci. 7, 29. <https://doi.org/10.3389/fnbeh.2013.00029>
- 1480 Kirkerud, N.H., Schlegel, U., Giovanni Galizia, C., 2017. Aversive Learning of Colored Lights in Walking  
1481 Honeybees. Front. Behav. Neurosci. 11, 94. <https://doi.org/10.3389/fnbeh.2017.00094>

- 1482 Kiya, T., Kunieda, T., Kubo, T., 2007. Increased Neural Activity of a Mushroom Body Neuron Subtype  
1483 in the Brains of Forager Honeybees. *PLOS ONE* 2, e371.  
1484 <https://doi.org/10.1371/journal.pone.0000371>
- 1485 Kócsi, Z., Murray, T., Dahmen, H., Narendra, A., Zeil, J., 2020. The Antarium: A Reconstructed Visual  
1486 Reality Device for Ant Navigation Research. *Front. Behav. Neurosci.* 14, 599374.  
1487 <https://doi.org/10.3389/fnbeh.2020.599374>
- 1488 Komischke, B., Sandoz, J.-C., Malun, D., Giurfa, M., 2005. Partial unilateral lesions of the mushroom  
1489 bodies affect olfactory learning in honeybees *Apis mellifera* L. *Eur. J. Neurosci.* 21, 477–485.  
1490 <https://doi.org/10.1111/j.1460-9568.2005.03879.x>
- 1491 Kramer, E., 1976. The orientation of walking honeybees in odour fields with small concentration  
1492 gradients. *Physiol. Entomol.* 1, 27–37. <https://doi.org/10.1111/j.1365-3032.1976.tb00883.x>
- 1493 Kuntz, S., Poeck, B., Sokolowski, M.B., Strauss, R., 2012. The visual orientation memory of *Drosophila*  
1494 requires Foraging (PKG) upstream of Ignorant (RSK2) in ring neurons of the central complex.  
1495 *Learn. Mem.* 19, 337–340. <https://doi.org/10.1101/lm.026369.112>
- 1496 Kuntz, S., Poeck, B., Strauss, R., 2017. Visual Working Memory Requires Permissive and Instructive  
1497 NO/cGMP Signaling at Presynapses in the *Drosophila* Central Brain. *Curr. Biol.* 27, 613–623.  
1498 <https://doi.org/10.1016/j.cub.2016.12.056>
- 1499 Kuwabara, M., 1957. Bildung des bedingten Reflexes von Pavlovs Typus bei der Honigbiene, *Apis*  
1500 *mellifica* (Mit 1 Textabbildung) 13, 458–464.
- 1501 Laloi, D., Sandoz, J. c., Picard-Nizou, A. l., Marchesi, A., Pouvreau, A., Taséi, J. n., Poppy, G., Pham-  
1502 delègue, M. h., 1999. Olfactory conditioning of the proboscis extension in bumble bees.  
1503 *Entomol. Exp. Appl.* 90, 123–129. <https://doi.org/10.1046/j.1570-7458.1999.00430.x>
- 1504 Lamberts, K., Lamberts, K., Shanks, D., 1998. Knowledge Concepts and Categories. Psychology Press,  
1505 London. <https://doi.org/10.4324/9780203765418>
- 1506 Li, L., MaBouDi, H., Egertová, M., Elphick, M.R., Chittka, L., Perry, C.J., 2017. A possible structural  
1507 correlate of learning performance on a colour discrimination task in the brain of the  
1508 bumblebee. *Proc. R. Soc. B Biol. Sci.* 284, 20171323. <https://doi.org/10.1098/rspb.2017.1323>
- 1509 Liu, G., Seiler, H., Wen, A., Zars, T., Ito, K., Wolf, R., Heisenberg, M., Liu, L., 2006. Distinct memory  
1510 traces for two visual features in the *Drosophila* brain. *Nature* 439, 551–556.  
1511 <https://doi.org/10.1038/nature04381>
- 1512 Loesche, F., Reiser, M.B., 2021. An Inexpensive, High-Precision, Modular Spherical Treadmill Setup  
1513 Optimized for *Drosophila* Experiments. *Front. Behav. Neurosci.* 15, 138.  
1514 <https://doi.org/10.3389/fnbeh.2021.689573>
- 1515 Lozano, V., Armengaud, C., Gauthier, M., 2001. Memory impairment induced by cholinergic  
1516 antagonists injected into the mushroom bodies of the honeybee. *J. Comp. Physiol. A* 187,  
1517 249–254. <https://doi.org/10.1007/s003590100196>
- 1518 Luu, T., Cheung, A., Ball, D., Srinivasan, M.V., 2011. Honeybee flight: A novel “streamlining” response.  
1519 *J. Exp. Biol.* 214, 2215–2225. <https://doi.org/10.1242/jeb.050310>
- 1520 Marchal, P., Villar, M.E., Geng, H., Arrufat, P., Combe, M., Viola, H., Massou, I., Giurfa, M., 2019.  
1521 Inhibitory learning of phototaxis by honeybees in a passive-avoidance task. *Learn. Mem.* 26,  
1522 412–423. <https://doi.org/10.1101/lm.050120.119>
- 1523 Martin, J.P., Guo, P., Mu, L., Harley, C.M., Ritzmann, R.E., 2015. Central-Complex Control of  
1524 Movement in the Freely Walking Cockroach. *Curr. Biol.* 25, 2795–2803.  
1525 <https://doi.org/10.1016/j.cub.2015.09.044>
- 1526 Masuhr, T., Menzel, R., 1972. Learning Experiments on the Use of Side — Specific Information in the  
1527 Olfactory and Visual System in the Honey Bee (*Apis mellifica*), in: Wehner, R. (Ed.),  
1528 Information Processing in the Visual Systems of Anthropods: Symposium Held at the  
1529 Department of Zoology, University of Zurich, March 6–9, 1972. Springer, Berlin, Heidelberg,  
1530 pp. 315–321. [https://doi.org/10.1007/978-3-642-65477-0\\_45](https://doi.org/10.1007/978-3-642-65477-0_45)
- 1531 Matsumoto, Y., Menzel, R., Sandoz, J.-C., Giurfa, M., 2012. Revisiting olfactory classical conditioning  
1532 of the proboscis extension response in honey bees: A step toward standardized procedures.  
1533 *J. Neurosci. Methods* 211, 159–167. <https://doi.org/10.1016/j.jneumeth.2012.08.018>

- 1534 Mauerlshagen, J., 1993. Neural correlates of olfactory learning paradigms in an identified neuron in  
1535 the honeybee brain. *J. Neurophysiol.* 69, 609–625. <https://doi.org/10.1152/jn.1993.69.2.609>
- 1536 Menzel, R., 2009. Serial Position Learning in Honeybees. *PLoS ONE* 4, e4694.  
1537 <https://doi.org/10.1371/journal.pone.0004694>
- 1538 Menzel, R., 1999. Memory dynamics in the honeybee. *J. Comp. Physiol. A* 185, 323–340.  
1539 <https://doi.org/10.1007/s003590050392>
- 1540 Menzel, R., 1974. Spectral Sensitivity of Monopolar Cells in the Bee Lamina. *J Comp Physiol A* 93,  
1541 337–346. <https://doi.org/10.1007/BF00606801>
- 1542 Menzel, R., 1967. Untersuchungen zum Erlernen von Spektralfarben durch die Honigbiene (*Apis*  
1543 *mellifica*). *Z. Für Vgl. Physiol.* 56, 22–62. <https://doi.org/10.1007/BF00333562>
- 1544 Menzel, R., Ventura, D.F., Hertel, H., de Souza, J.M., Greggers, U., 1986. Spectral sensitivity of  
1545 photoreceptors in insect compound eyes: Comparison of species and methods. *J. Comp.*  
1546 *Physiol. A* 158, 165–177. <https://doi.org/10.1007/BF01338560>
- 1547 Menzel, Randolph, 1979. Spectral Sensitivity and Color Vision in Invertebrates, in: Autrum, H., Bennett,  
1548 M.F., Diehn, B., Hamdorf, K., Heisenberg, M., Järvilehto, M., Kunze, P., Menzel, R., Miller,  
1549 W.H., Snyder, A.W., Stavenga, D.G., Yoshida, M., Autrum, H. (Eds.), *Comparative Physiology*  
1550 *and Evolution of Vision in Invertebrates: A: Invertebrate Photoreceptors, Handbook of*  
1551 *Sensory Physiology.* Springer, Berlin, Heidelberg, pp. 503–580. [https://doi.org/10.1007/978-](https://doi.org/10.1007/978-3-642-66999-6_9)  
1552 [3-642-66999-6\\_9](https://doi.org/10.1007/978-3-642-66999-6_9)
- 1553 Meyer, A., Galizia, C.G., 2012. Elemental and configural olfactory coding by antennal lobe neurons of  
1554 the honeybee (*Apis mellifera*). *J. Comp. Physiol. A Neuroethol. Sens. Neural. Behav. Physiol.*  
1555 198, 159–171. <https://doi.org/10.1007/s00359-011-0696-8>
- 1556 Minatohara, K., Akiyoshi, M., Okuno, H., 2016. Role of Immediate-Early Genes in Synaptic Plasticity  
1557 and Neuronal Ensembles Underlying the Memory Trace. *Front. Mol. Neurosci.* 8, 78.  
1558 <https://doi.org/10.3389/fnmol.2015.00078>
- 1559 Minnich, D.E., 1921. An experimental study of the tarsal chemoreceptors of two nymphalid  
1560 butterflies. *J. Exp. Zool.* 33, 172–203. <https://doi.org/10.1002/jez.1400330105>
- 1561 Mizunami, M., Unoki, S., Mori, Y., Hirashima, D., Hatano, A., Matsumoto, Y., 2009. Roles of  
1562 octopaminergic and dopaminergic neurons in appetitive and aversive memory recall in an  
1563 insect. *BMC Biol.* 7, 46. <https://doi.org/10.1186/1741-7007-7-46>
- 1564 Mobbs, P.G., 1984. Neural networks in the mushroom bodies of the honeybee. *J. Insect Physiol.* 30,  
1565 43–58. [https://doi.org/10.1016/0022-1910\(84\)90107-0](https://doi.org/10.1016/0022-1910(84)90107-0)
- 1566 Mobbs, P.G., Young, J.Z., 1982. The brain of the honeybee *Apis mellifera*. I. The connections and  
1567 spatial organization of the mushroom bodies. *Philos. Trans. R. Soc. Lond. B Biol. Sci.* 298,  
1568 309–354. <https://doi.org/10.1098/rstb.1982.0086>
- 1569 Moore, R.J.D., Taylor, G.J., Paulk, A.C., Pearson, T., van Swinderen, B., Srinivasan, M.V., 2014. FicTrac:  
1570 A visual method for tracking spherical motion and generating fictive animal paths. *J.*  
1571 *Neurosci. Methods* 225, 106–119. <https://doi.org/10.1016/j.jneumeth.2014.01.010>
- 1572 Mota, T., Giurfa, M., Sandoz, J.-C., 2011. Color modulates olfactory learning in honeybees by an  
1573 occasion-setting mechanism. *Learn. Mem.* 18, 144–155. <https://doi.org/10.1101/lm.2073511>
- 1574 Mota, T., Gronenberg, W., Giurfa, M., Sandoz, J.-C., 2013. Chromatic processing in the anterior optic  
1575 tubercle of the honey bee brain. *J. Neurosci. Off. J. Soc. Neurosci.* 33, 4–16.  
1576 <https://doi.org/10.1523/JNEUROSCI.1412-12.2013>
- 1577 Mota, T., Kreissl, S., Carrasco Durán, A., Lefer, D., Galizia, G., Giurfa, M., 2016. Synaptic Organization  
1578 of Microglomerular Clusters in the Lateral and Medial Bulbs of the Honeybee Brain. *Front.*  
1579 *Neuroanat.* 10, 103. <https://doi.org/10.3389/fnana.2016.00103>
- 1580 Mota, Theo, Roussel, E., Sandoz, J.-C., Giurfa, M., 2011a. Visual conditioning of the sting extension  
1581 reflex in harnessed honeybees. *J. Exp. Biol.* 214, 3577–3587.  
1582 <https://doi.org/10.1242/jeb.062026>
- 1583 Mota, Theo, Yamagata, N., Giurfa, M., Gronenberg, W., Sandoz, J.-C., 2011b. Neural organization and  
1584 visual processing in the anterior optic tubercle of the honeybee brain. *J. Neurosci. Off. J. Soc.*  
1585 *Neurosci.* 31, 11443–11456. <https://doi.org/10.1523/JNEUROSCI.0995-11.2011>

- 1586 Mureli, S., Thanigaivelan, I., Schaffer, M.L., Fox, J.L., 2017. Cross-modal influence of mechanosensory  
1587 input on gaze responses to visual motion in *Drosophila*. *J. Exp. Biol.* 220, 2218–2227.  
1588 <https://doi.org/10.1242/jeb.146282>
- 1589 Neuser, K., Triphan, T., Mronz, M., Poeck, B., Strauss, R., 2008. Analysis of a spatial orientation  
1590 memory in *Drosophila*. *Nature* 453, 1244–1247. <https://doi.org/10.1038/nature07003>
- 1591 Núñez, J., Almeida, L., Balderrama, N., Giurfa, M., 1997. Alarm Pheromone Induces Stress Analgesia  
1592 via an Opioid System in the Honeybee. *Physiol. Behav.* 63, 75–80.  
1593 [https://doi.org/10.1016/S0031-9384\(97\)00391-0](https://doi.org/10.1016/S0031-9384(97)00391-0)
- 1594 Ofstad, T.A., Zuker, C.S., Reiser, M.B., 2011. Visual place learning in *Drosophila melanogaster*. *Nature*  
1595 474, 204–207. <https://doi.org/10.1038/nature10131>
- 1596 Paffhausen, B.H., Fuchs, I., Duer, A., Hillmer, I., Dimitriou, I.M., Menzel, R., 2020. Neural Correlates of  
1597 Social Behavior in Mushroom Body Extrinsic Neurons of the Honeybee *Apis mellifera*. *Front.*  
1598 *Behav. Neurosci.* 14, 62. <https://doi.org/10.3389/fnbeh.2020.00062>
- 1599 Paffhausen, B.H., Petrasch, J., Wild, B., Meurers, T., Schülke, T., Polster, J., Fuchs, I., Drexler, H.,  
1600 Kuriatnyk, O., Menzel, R., Landgraf, T., 2021. A Flying Platform to Investigate Neuronal  
1601 Correlates of Navigation in the Honey Bee (*Apis mellifera*). *Front. Behav. Neurosci.* 15,  
1602 690571. <https://doi.org/10.3389/fnbeh.2021.690571>
- 1603 Pan, Y., Zhou, Y., Guo, C., Gong, H., Gong, Z., Liu, L., 2009. Differential roles of the fan-shaped body  
1604 and the ellipsoid body in *Drosophila* visual pattern memory. *Learn. Mem.* 16, 289–295.  
1605 <https://doi.org/10.1101/lm.1331809>
- 1606 Paulk, A.C., Dacks, A.M., Gronenberg, W., 2009a. Color processing in the medulla of the bumblebee  
1607 (*Apidae: Bombus impatiens*). *J. Comp. Neurol.* 513, 441–456.  
1608 <https://doi.org/10.1002/cne.21993>
- 1609 Paulk, A.C., Dacks, A.M., Phillips-Portillo, J., Fellous, J.-M., Gronenberg, W., 2009b. Visual Processing  
1610 in the Central Bee Brain. *J. Neurosci.* 29, 9987–9999.  
1611 <https://doi.org/10.1523/JNEUROSCI.1325-09.2009>
- 1612 Paulk, A.C., Gronenberg, W., 2008. Higher order visual input to the mushroom bodies in the bee,  
1613 *Bombus impatiens*. *Arthropod Struct. Dev.* 37, 443–458.  
1614 <https://doi.org/10.1016/j.asd.2008.03.002>
- 1615 Paulk, A.C., Kirszenblat, L., Zhou, Y., van Swinderen, B., 2015. Closed-Loop Behavioral Control  
1616 Increases Coherence in the Fly Brain. *J. Neurosci.* 35, 10304–10315.  
1617 <https://doi.org/10.1523/JNEUROSCI.0691-15.2015>
- 1618 Paulk, A.C., Phillips-Portillo, J., Dacks, A.M., Fellous, J.-M., Gronenberg, W., 2008. The Processing of  
1619 Color, Motion, and Stimulus Timing Are Anatomically Segregated in the Bumblebee Brain. *J.*  
1620 *Neurosci.* 28, 6319–6332. <https://doi.org/10.1523/JNEUROSCI.1196-08.2008>
- 1621 Paulk, A.C., Stacey, J.A., Pearson, T.W.J., Taylor, G.J., Moore, R.J.D., Srinivasan, M.V., Swinderen, B.  
1622 van, 2014a. Selective attention in the honeybee optic lobes precedes behavioral choices.  
1623 *Proc. Natl. Acad. Sci.* 111, 5006–5011. <https://doi.org/10.1073/pnas.1323297111>
- 1624 Paulk, A.C., Stacey, J.A., Pearson, T.W.J., Taylor, G.J., Moore, R.J.D., Srinivasan, M.V., Swinderen, B.  
1625 van, 2014b. Selective attention in the honeybee optic lobes precedes behavioral choices.  
1626 *Proc. Natl. Acad. Sci.* 111, 5006–5011. <https://doi.org/10.1073/pnas.1323297111>
- 1627 Peitsch, D., Fietz, A., Hertel, H., de Souza, J., Ventura, D.F., Menzel, R., 1992. The spectral input  
1628 systems of hymenopteran insects and their receptor-based colour vision. *J. Comp. Physiol. A*  
1629 170, 23–40. <https://doi.org/10.1007/BF00190398>
- 1630 Pfeiffer, K., Homberg, U., 2014. Organization and Functional Roles of the Central Complex in the  
1631 Insect Brain. *Annu. Rev. Entomol.* 59, 165–184. <https://doi.org/10.1146/annurev-ento-011613-162031>
- 1632 Pfeiffer, K., Homberg, U., 2007. Coding of Azimuthal Directions via Time-Compensated Combination  
1633 of Celestial Compass Cues. *Curr. Biol.* 17, 960–965.  
1634 <https://doi.org/10.1016/j.cub.2007.04.059>
- 1635

- 1636 Plath, J.A., Barron, A.B., 2015. Current progress in understanding the functions of the insect central  
1637 complex. *Curr. Opin. Insect Sci., Neuroscience \* Special Section: Insect conservation* 12, 11–  
1638 18. <https://doi.org/10.1016/j.cois.2015.08.005>
- 1639 Plath, J.A., Entler, B.V., Kirkerud, N.H., Schlegel, U., Galizia, C.G., Barron, A.B., 2017. Different Roles  
1640 for Honey Bee Mushroom Bodies and Central Complex in Visual Learning of Colored Lights in  
1641 an Aversive Conditioning Assay. *Front. Behav. Neurosci.* 11.  
1642 <https://doi.org/10.3389/fnbeh.2017.00098>
- 1643 Poll, M.N.V.D., Zajackowski, E.L., Taylor, G.J., Srinivasan, M.V., Swindereen, B. van, 2015. Using an  
1644 abstract geometry in virtual reality to explore choice behaviour: visual flicker preferences in  
1645 honeybees. *J. Exp. Biol.* 218, 3448–3460. <https://doi.org/10.1242/jeb.125138>
- 1646 Rapaport, A., 1973. [Instrumental deconditioning of the young rat conditioned to an ambient  
1647 temperature of 40 degrees C with the operational technic of B. F. Skinner]. *C. R. Seances Soc.*  
1648 *Biol. Fil.* 167, 900–903.
- 1649 Rebenitsch, L., Owen, C., 2016. Review on cybersickness in applications and visual displays. *Virtual*  
1650 *Real.* 20, 101–125. <https://doi.org/10.1007/s10055-016-0285-9>
- 1651 Reiser, M.B., Dickinson, M.H., 2008. A modular display system for insect behavioral neuroscience. *J.*  
1652 *Neurosci. Methods* 167, 127–139. <https://doi.org/10.1016/j.jneumeth.2007.07.019>
- 1653 Ren, Q., Li, H., Wu, Y., Ren, J., Guo, A., 2012. A GABAergic inhibitory neural circuit regulates visual  
1654 reversal learning in *Drosophila*. *J. Neurosci. Off. J. Soc. Neurosci.* 32, 11524–11538.  
1655 <https://doi.org/10.1523/JNEUROSCI.0827-12.2012>
- 1656 Ribi, W.A., 1975. The first optic ganglion of the bee. *Cell Tissue Res.* 165, 103–111.  
1657 <https://doi.org/10.1007/BF00222803>
- 1658 Ribi, W.A., Scheel, M., 1981. The second and third optic ganglia of the worker bee: Golgi studies of  
1659 the neuronal elements in the medulla and lobula. *Cell Tissue Res.* 221, 17–43.  
1660 <https://doi.org/10.1007/BF00216567>
- 1661 Riveros, A.J., Gronenberg, W., 2009. Olfactory learning and memory in the bumblebee *Bombus*  
1662 *occidentalis*. *Naturwissenschaften* 96, 851–856. <https://doi.org/10.1007/s00114-009-0532-y>
- 1663 Roubieu, F.L., Serres, J.R., Colonnier, F., Franceschini, N., Viollet, S., Ruffier, F., 2014. A biomimetic  
1664 vision-based hovercraft accounts for bees' complex behaviour in various corridors. *Bioinspir.*  
1665 *Biomim.* 9, 036003. <https://doi.org/10.1088/1748-3182/9/3/036003>
- 1666 Rusch, C., Alonso San Alberto, D., Riffell, J.A., 2021. Visuo-motor feedback modulates neural activities  
1667 in the medulla of the honeybee, *Apis mellifera*. *J. Neurosci. Off. J. Soc. Neurosci.*  
1668 <https://doi.org/10.1523/JNEUROSCI.1824-20.2021>
- 1669 Rusch, C., Roth, E., Vinauger, C., Riffell, J.A., 2017. Honeybees in a virtual reality environment learn  
1670 unique combinations of colour and shape. *J. Exp. Biol.* 220, 3478–3487.  
1671 <https://doi.org/10.1242/jeb.164731>
- 1672 Rybak, J., Menzel, R., 1993. Anatomy of the mushroom bodies in the honey bee brain: the neuronal  
1673 connections of the alpha-lobe. *J. Comp. Neurol.* 334, 444–465.  
1674 <https://doi.org/10.1002/cne.903340309>
- 1675 Sakura, M., Okada, R., Aonuma, H., 2012. Evidence for instantaneous e-vector detection in the  
1676 honeybee using an associative learning paradigm. *Proc. R. Soc. B Biol. Sci.* 279, 535–542.  
1677 <https://doi.org/10.1098/rspb.2011.0929>
- 1678 Scheiner, R., Abramson, C.I., Brodschneider, R., Crailsheim, K., Farina, W.M., Fuchs, S., Gruenewald,  
1679 B., Hahshold, S., Karrer, M., Koeniger, G., Koeniger, N., Menzel, R., Mujagic, S., Radspieler, G.,  
1680 Schmickl, T., Schneider, C., Siegel, A.J., Szopek, M., Thenius, R., 2013. Standard methods for  
1681 behavioural studies of *Apis mellifera*. *J. Apic. Res.* 52.
- 1682 Schultheiss, P., Buatois, A., Avarguès-Weber, A., Giurfa, M., 2017. Using virtual reality to study visual  
1683 performances of honeybees. *Curr. Opin. Insect Sci.* 24, 43–50.  
1684 <https://doi.org/10.1016/j.cois.2017.08.003>
- 1685 Schwaerzel, M., Monastirioti, M., Scholz, H., Friggi-Grelin, F., Birman, S., Heisenberg, M., 2003.  
1686 Dopamine and octopamine differentiate between aversive and appetitive olfactory  
1687 memories in *Drosophila*. *J. Neurosci. Off. J. Soc. Neurosci.* 23, 10495–10502.

- 1688 Skorupski, P., MaBouDi, H., Galpayage Dona, H.S., Chittka, L., 2018. Counting insects. *Philos. Trans. R.*  
1689 *Soc. B Biol. Sci.* 373, 20160513. <https://doi.org/10.1098/rstb.2016.0513>
- 1690 Sommerlandt, F.M.J., Brockmann, A., Rössler, W., Spaethe, J., 2019. Immediate early genes in social  
1691 insects: a tool to identify brain regions involved in complex behaviors and molecular  
1692 processes underlying neuroplasticity. *Cell. Mol. Life Sci.* 76, 637–651.  
1693 <https://doi.org/10.1007/s00018-018-2948-z>
- 1694 Sommerlandt, F.M.J., Spaethe, J., Rössler, W., Dyer, A.G., 2016. Does Fine Color Discrimination  
1695 Learning in Free-Flying Honeybees Change Mushroom-Body Calyx Neuroarchitecture? *PLoS*  
1696 *ONE* 11, e0164386. <https://doi.org/10.1371/journal.pone.0164386>
- 1697 Srinivasan, M.V., 2010. Honey Bees as a Model for Vision, Perception, and Cognition. *Annu. Rev.*  
1698 *Entomol.* 55, 267–284. <https://doi.org/10.1146/annurev.ento.010908.164537>
- 1699 Srinivasan, M.V., Lehrer, M., 1988. Spatial acuity of honeybee vision and its spectral properties. *J.*  
1700 *Comp. Physiol. A* 162, 159–172. <https://doi.org/10.1007/BF00606081>
- 1701 Srinivasan, M.V., Lehrer, M., 1984. Temporal acuity of honeybee vision: behavioural studies using  
1702 moving stimuli. *J. Comp. Physiol. A* 155, 297–312. <https://doi.org/10.1007/BF00610583>
- 1703 Srinivasan, M.V., Lehrer, M., Kirchner, W.H., Zhang, S.W., 1991. Range perception through apparent  
1704 image speed in freely flying honeybees. *Vis. Neurosci.* 6, 519–535.  
1705 <https://doi.org/10.1017/S095252380000136X>
- 1706 Strausfeld, N.J., Sinakevitch, I., Vilinsky, I., 2003. The mushroom bodies of *Drosophila melanogaster*:  
1707 An immunocytological and golgi study of Kenyon cell organization in the calyces and lobes.  
1708 *Microsc. Res. Tech.* 62, 151–169. <https://doi.org/10.1002/jemt.10368>
- 1709 Strube-Bloss, M.F., Rössler, W., 2018. Multimodal integration and stimulus categorization in putative  
1710 mushroom body output neurons of the honeybee. *R. Soc. Open Sci.* 5, 171785.  
1711 <https://doi.org/10.1098/rsos.171785>
- 1712 Takeda, K., 1961. Classical conditioned response in the honey bee. *J. Insect Physiol.* 6, 168–179.  
1713 [https://doi.org/10.1016/0022-1910\(61\)90060-9](https://doi.org/10.1016/0022-1910(61)90060-9)
- 1714 Taylor, G.J., Luu, T., Ball, D., Srinivasan, M.V., 2013. Vision and air flow combine to streamline flying  
1715 honeybees. *Sci. Rep.* 3. <https://doi.org/10.1038/srep02614>
- 1716 Taylor, G.J., Paulk, A.C., Pearson, T.W.J., Moore, R.J.D., Stacey, J.A., Ball, D., Swindereen, B. van,  
1717 Srinivasan, M.V., 2015. Insects modify their behaviour depending on the feedback sensor  
1718 used when walking on a trackball in virtual reality. *J. Exp. Biol.* 218, 3118–3127.  
1719 <https://doi.org/10.1242/jeb.125617>
- 1720 Tedjakumala, S.R., Aimable, M., Giurfa, M., 2013. Pharmacological modulation of aversive  
1721 responsiveness in honey bees. *Front. Behav. Neurosci.* 7, 221.  
1722 <https://doi.org/10.3389/fnbeh.2013.00221>
- 1723 Tedjakumala, S.R., Giurfa, M., 2013. Rules and mechanisms of punishment learning in honey bees:  
1724 the aversive conditioning of the sting extension response. *J. Exp. Biol.* 216, 2985–2997.  
1725 <https://doi.org/10.1242/jeb.086629>
- 1726 Tedore, C., Johnsen, S., 2017. Using RGB displays to portray color realistic imagery to animal eyes.  
1727 *Curr. Zool.* 63, 27–34. <https://doi.org/10.1093/cz/zow076>
- 1728 Triphan, T., Poeck, B., Neuser, K., Strauss, R., 2010. Visual Targeting of Motor Actions in Climbing  
1729 *Drosophila*. *Curr. Biol.* 20, 663–668. <https://doi.org/10.1016/j.cub.2010.02.055>
- 1730 Unoki, S., Matsumoto, Y., Mizunami, M., 2005. Participation of octopaminergic reward system and  
1731 dopaminergic punishment system in insect olfactory learning revealed by pharmacological  
1732 study. *Eur. J. Neurosci.* 22, 1409–1416. <https://doi.org/10.1111/j.1460-9568.2005.04318.x>
- 1733 Van Swindereen, B., 2012. Competing visual flicker reveals attention-like rivalry in the fly brain. *Front.*  
1734 *Integr. Neurosci.* 6. <https://doi.org/10.3389/fnint.2012.00096>
- 1735 Vergoz, V., Roussel, E., Sandoz, J.-C., Giurfa, M., 2007. Aversive Learning in Honeybees Revealed by  
1736 the Olfactory Conditioning of the Sting Extension Reflex. *PLOS ONE* 2, e288.  
1737 <https://doi.org/10.1371/journal.pone.0000288>

- 1738 Vogt, K., Schnaitmann, C., Dylla, K.V., Knapek, S., Aso, Y., Rubin, G.M., Tanimoto, H., 2014. Shared  
1739 mushroom body circuits underlie visual and olfactory memories in *Drosophila*. *eLife* 3,  
1740 e02395. <https://doi.org/10.7554/eLife.02395>
- 1741 Von Frisch, K., 1914. Der Farbensinn und Formensinn der Biene. *Zool Jb Physiol* 1–238.
- 1742 Vorobyev, M., Gumbert, A., Kunze, J., Giurfa, M., Menzel, R., 1997. FLOWERS THROUGH INSECT EYES.  
1743 *Isr. J. Plant Sci.* 45, 93–101. <https://doi.org/10.1080/07929978.1997.10676676>
- 1744 Wehner, R., 1967. Pattern Recognition in Bees. *Nature* 215, 1244–1248.  
1745 <https://doi.org/10.1038/2151244a0>
- 1746 Whitlow, J.W., Wagner, A.R., 1972. Negative patterning in classical conditioning: Summation of  
1747 response tendencies to isolable and configurai components. *Psychon. Sci.* 27, 299–301.  
1748 <https://doi.org/10.3758/BF03328970>
- 1749 Yang, E.-C., Lin, H.-C., Hung, Y.-S., 2004. Patterns of chromatic information processing in the lobula of  
1750 the honeybee, *Apis mellifera* L. *J. Insect Physiol.* 50, 913–925.  
1751 <https://doi.org/10.1016/j.jinsphys.2004.06.010>
- 1752 Yilmaz, A., Grübel, K., Spaethe, J., Rössler, W., 2019. Distributed plasticity in ant visual pathways  
1753 following colour learning. *Proc. Biol. Sci.* 286, 20182813.  
1754 <https://doi.org/10.1098/rspb.2018.2813>
- 1755 Zentall, T.R., Galizio, M., Critchfield, T.S., 2002. Categorization, Concept Learning, and Behavior  
1756 Analysis: An Introduction. *J. Exp. Anal. Behav.* 78, 237–248.  
1757 <https://doi.org/10.1901/jeab.2002.78-237>
- 1758 Zentall, T.R., Wasserman, E.A., Lazareva, O.F., Thompson, R.K.R., Rattermann, M.J., 2008. Concept  
1759 learning in animals. *Comp. Cogn. Behav. Rev.* 3, 13–45.  
1760 <https://doi.org/10.3819/ccbr.2008.30002>
- 1761 Zhang, S., 2012. Visually Guided Decision Making in Foraging Honeybees. *Front. Neurosci.* 6, 88.  
1762 <https://doi.org/10.3389/fnins.2012.00088>
- 1763 Zhang, S., Bock, F., Si, A., Tautz, J., Srinivasan, M.V., 2005. Visual working memory in decision making  
1764 by honey bees. *Proc. Natl. Acad. Sci.* 102, 5250–5255.  
1765 <https://doi.org/10.1073/pnas.0501440102>
- 1766 Zhang, S.W., Bartsch, K., Srinivasan, M.V., 1996. Maze Learning by Honeybees. *Neurobiol. Learn.*  
1767 *Mem.* 66, 267–282. <https://doi.org/10.1006/nlme.1996.0069>
- 1768 Zhang, S.W., Lehrer, M., Srinivasan, M.V., 1999. Honeybee Memory: Navigation by Associative  
1769 Grouping and Recall of Visual Stimuli. *Neurobiol. Learn. Mem.* 72, 180–201.  
1770 <https://doi.org/10.1006/nlme.1998.3901>
- 1771 Zhang, S.W., Lehrer, M., Srinivasan, M.V., 1998. Eye-specific learning of routes and “signposts” by  
1772 walking honeybees. *J. Comp. Physiol. A* 182, 747–754.  
1773 <https://doi.org/10.1007/s003590050219>
- 1774 Zhang, S.W., Srinivasan, M.V., Horridge, G.A., 1992. Pattern recognition in honeybees: local and  
1775 global analysis. *Proc. R. Soc. Lond. B Biol. Sci.* 248, 55–61.  
1776 <https://doi.org/10.1098/rspb.1992.0042>
- 1777 Zwaka, H., Bartels, R., Grünewald, B., Menzel, R., 2018. Neural Organization of A3 Mushroom Body  
1778 Extrinsic Neurons in the Honeybee Brain. *Front. Neuroanat.* 12, 57.  
1779 <https://doi.org/10.3389/fnana.2018.00057>
- 1780 Zwaka, H., Bartels, R., Lehfeldt, S., Jusyte, M., Hantke, S., Menzel, S., Gora, J., Alberdi, R., Menzel, R.,  
1781 2019. Learning and Its Neural Correlates in a Virtual Environment for Honeybees. *Front.*  
1782 *Behav. Neurosci.* 12, 279. <https://doi.org/10.3389/fnbeh.2018.00279>
- 1783

## Chapter 1

1785

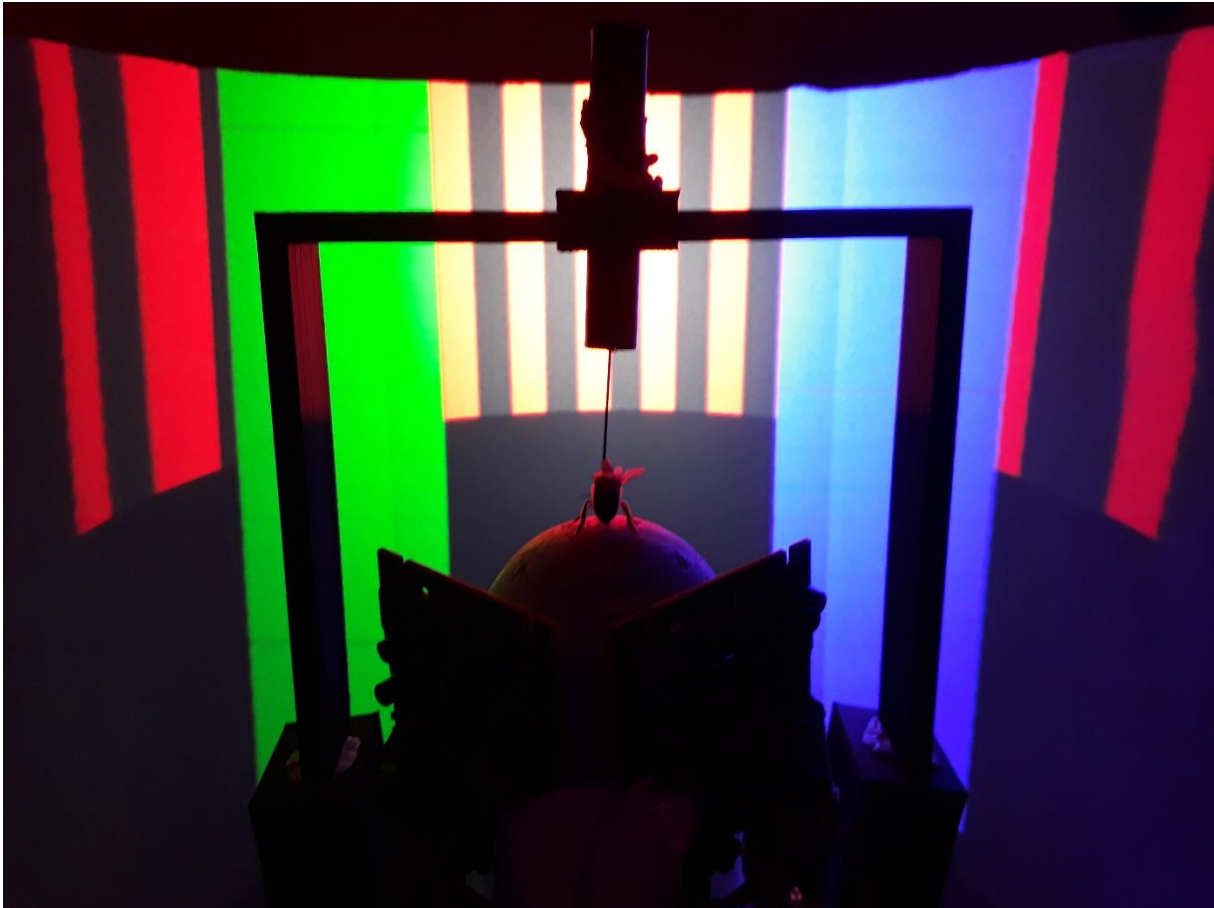
1786 **Motion cues from the background influence associative color learning of**1787 **honey bees in a virtual-reality scenario**

1788

1789



OPEN

## Motion cues from the background influence associative color learning of honey bees in a virtual-reality scenario

Gregory Lafon<sup>1</sup>, Scarlett R. Howard<sup>1,4</sup>, Benjamin H. Paffhausen<sup>1</sup>, Aurore Avarguès-Weber<sup>1,5</sup> & Martin Giurfa<sup>1,2,3,5</sup>✉

1790

1791 We developed a fully 3D virtual environment, in which tethered bees walking stationary can  
1792 explore a virtual arena and investigate and learn 3D objects. The presence of the third dimension  
1793 thus created a more complex and immersive VR in which we studied the incidence of motions  
1794 cues, induced either ventrally by displacements of the treadmill or frontally by virtual  
1795 movements in the VR itself, on visual discrimination in the VR landscape.

1796 We expected that the addition of motion cues would increase learning performances either by  
1797 creating a more immersive experience or simply by enhancing attention by increasing the  
1798 amount of movement on screen. However, we found that frontal background motion cues  
1799 impaired color discrimination. Ventral motion cues did not affect color discrimination but  
1800 influenced walking parameters. In this chapter, we present the various effects of motion cues  
1801 on visual learning and motor behavior, and provide potential explanations for their negative  
1802 impact on color discrimination.

1803

1804 **Motion cues from the background influence associative**  
1805 **color learning of honey bees in a virtual-reality scenario**  
1806

1807  
1808 **Gregory Lafon<sup>1</sup>, Scarlett R. Howard<sup>1</sup>✉, Benjamin H. Paffhausen<sup>1</sup>, Aurore**  
1809 **Avarguès-Weber<sup>1\*</sup> and Martin Giurfa<sup>1, 2, 3\*</sup>**  
1810

1811  
1812 <sup>1</sup> Research Centre on Animal Cognition, Center for Integrative Biology, CNRS (UMR 5169), University of Toulouse,  
1813 118 route de Narbonne, F-31062 Toulouse cedex 09, France

1814 <sup>2</sup> College of Animal Sciences (College of Bee Science), Fujian Agriculture and Forestry University, Fuzhou 350002,  
1815 China

1816 <sup>3</sup> Institut Universitaire de France (IUF), Paris, France

1817  
1818 ✉: *Present address:* School of Life & Environmental Sciences, Melbourne Burwood Campus, Deakin University,  
1819 Melbourne, VIC, Australia

1820

1821

1822 \* Senior authorship shared

1823

1824 **Running Title:** Motion Cues in Virtual Reality Learning by Bees

1825 **Correspondence to:** Martin Giurfa  
1826 Research Center on Animal Cognition  
1827 Center of Integrative Biology  
1828 CNRS - University Paul Sabatier - Toulouse III  
1829 4R4 Building - 4th Floor  
1830 118 Route de Narbonne  
1831 31062 Toulouse cedex 9  
1832 FRANCE  
1833

1834

## 1835 **Abstract**

1836

1837 Honey bees exhibit remarkable visual learning capacities, which can be studied using virtual  
1838 reality (VR) landscapes in laboratory conditions. Existing VR environments for bees are  
1839 imperfect as they provide either open-loop conditions or 2D displays. Here we achieved a true  
1840 3D environment in which walking bees learned to discriminate a rewarded from a punished  
1841 virtual stimulus based on color differences. We included ventral or frontal background cues,  
1842 which were also subjected to 3D updating based on the bee movements. We thus studied if and  
1843 how the presence of such motion cues affected visual discrimination in our VR landscape. Our  
1844 results showed that the presence of frontal, and to a lesser extent, of ventral background motion  
1845 cues impaired the bees' performance. Whenever these cues were suppressed, color  
1846 discrimination learning became possible. We analyzed the specific contribution of foreground  
1847 and background cues and discussed the role of attentional interference and differences in  
1848 stimulus salience in the VR environment to account for these results. Overall, we show how  
1849 background and target cues may interact at the perceptual level and influence associative  
1850 learning in bees. In addition, we identify issues that may affect decision-making in VR  
1851 landscapes, which require specific control by experimenters.

1852

## 1853 **Keywords**

1854

1855 Vision – Visual Learning – Color Discrimination – Optic Flow – Motion cues – Background  
1856 – Honey bees

1857

## 1858 Introduction

1859

1860 Understanding the spatiotemporal processes that guide decision-making in animals and humans  
1861 is essential in cognitive research and may be facilitated by virtual reality (VR)<sup>1,2</sup>, which allows  
1862 generating of immersive spatial environments in well-controlled laboratory settings. In such  
1863 environments, experiences are simulated based on changes of perceived landscapes or images,  
1864 which are updated based on the subject's own movements and decisions<sup>1,2</sup>.

1865 Insects have pioneered the implementation of VR paradigms aimed at studying  
1866 perceptual and cognitive capacities. A predecessor of current VR systems is the flight simulator  
1867 conceived for the fruit fly *Drosophila melanogaster*. In this setup, which was first used to study  
1868 how optical properties of compound eyes influence optomotor reactions<sup>3</sup>, a tethered fly flies  
1869 stationary in the middle of a cylindrical arena and experiences surrounding visual stimuli that  
1870 can be updated by the fly's movements. Newer versions of this apparatus are still used for  
1871 numerous studies on visual learning and memory in flies<sup>4-7</sup>. 'Locomotion compensators' were  
1872 also developed to study decision-making by walking insects on two-dimensional surfaces. In  
1873 silk moths and honey bees, for instance, a 'servosphere' - a form of spherical treadmill that  
1874 compensates every locomotive movement of a walking insect - was first used to study olfactory  
1875 orientation towards controlled odor stimuli such as pheromone components and odor  
1876 gradients<sup>8,9</sup>. Spherical treadmills have been used to study multiple behaviors in different insect  
1877 species. In these setups, the walking movements of the insect under study are constantly  
1878 monitored and translated into displacements of surrounding visual cues (closed-loop  
1879 conditions). The insect can be either free<sup>10,11</sup> or immobilized<sup>12-16</sup> by a tether glued onto its body  
1880 surface (typically on the thorax). In both cases, the insect walks stationary on a treadmill whose  
1881 movements are recorded by captors placed lateral or ventral to the treadmill.

1882 VR setups are particularly useful for the presentation of visual cues and the study of  
1883 visual performances. Screens consisting of LED bulb arrays are commonly employed to provide  
1884 simple forms of visual stimulation (<sup>17-19</sup>). In addition, stimuli projected onto screens by high-  
1885 rate video-projectors have also been used on walking arthropods (e.g.<sup>12-14,16,20</sup>). Furthermore,  
1886 treadmills holding a tethered animal can also be set in natural visual surroundings to study the  
1887 influence of landscape features on navigation performances<sup>10</sup>.

1888 Owing to their status of classic models for the study of visual cognition<sup>21-23</sup>, the visual  
1889 performances of honeybees (*Apis mellifera*) have recently started to be studied in VR setups.  
1890 The main drive to develop these studies was the impossibility to access the neural underpinnings  
1891 of visual performances in free-flying bees, which have been traditionally used to study basic

1892 properties of visual learning and perception<sup>24</sup>. Immobilized bees have been traditionally  
1893 required for population recordings of neural activity in the bee brain<sup>25,26</sup>, thus precluding the  
1894 possibility of recording active visually-driven behaviors. VR setups in which a tethered animal  
1895 makes decision based on visual cues represent a suitable solution to overcome these limitations  
1896 as they provide access both to behavioral output and to the nervous system of a behaving bee  
1897 with restricted mobility<sup>27,28</sup>. This perspective is supported by recent developments allowing to  
1898 record from specific neurons in the brain of walking bees<sup>16,27,29-31</sup>. Yet, the development of VR  
1899 environments requires considerable work in order to adapt visual displays to the subjective  
1900 perception of an insect and determine optimal parameters for immersive sensations from an  
1901 insect's perspective.

1902         Prior work allowed the development of virtual-reality (VR) systems in which a tethered  
1903 honey bee walks stationary on a spherical treadmill (a Styrofoam ball floating on an air cushion)  
1904 while perceiving a virtual environment displayed by a video projector onto a semicircular  
1905 screen<sup>12-16,27</sup>. In most cases, however, the visual stimulation provided consisted of a 2D virtual  
1906 environment in which only translational image movement (left-right) was coupled to the bees'  
1907 movements, thus providing an imperfect immersive environment. Despite the absence of depth  
1908 components, bees learned both elemental (e.g. discrimination between blue vs. green discs or  
1909 squares)<sup>12-14</sup> and non-elemental discriminations (e.g. the negative patterning problem in which  
1910 responding to a visual compound, but not to its components, has to be suppressed)<sup>15</sup>, thus  
1911 showing the suitability of VR for the study of visual learning.

1912         Here we introduce an improved version of our prior VR setup in which a custom-made  
1913 software allowed us to create a 3D virtual landscape in which bees move and learn to  
1914 discriminate visual stimuli. This modification introduced depth perception estimated via the  
1915 optic flow generated by the bee's own movements as a new variable, whose influence on the  
1916 visual discrimination needs to be considered. In this new scenario, motion cues were not only  
1917 derived from the targets themselves, but also from the background presented either 'behind' the  
1918 vertically displayed targets or ventrally, on the walking surface. We therefore studied if and  
1919 how the addition of these motion cues to our VR setup affects learning and discrimination in  
1920 tethered bees.

1921

1922

## 1923 **Materials and methods**

### 1924 **Study species and collection**

1925 Honey bee foragers (*Apis mellifera*) were obtained from the CRCA apiary located in the campus  
1926 of the University Paul Sabatier. Foragers were captured at gravity feeders providing 0.88 M  
1927 sucrose solution upon landing and before they began feeding. This step is important as it ensures  
1928 that only bees with the appropriate appetitive motivation were brought to the laboratory for the  
1929 visual learning experiments. Captured bees were enclosed in individual glass vials and then  
1930 transferred to small cages housing ten bees in average; where they had access to *ad libitum*  
1931 water and 300  $\mu$ l of 1.5 M sucrose solution. They were then kept overnight in an incubator at  
1932 28°C and 80% humidity. On the next day, each bee was cooled on ice for 5 minutes to  
1933 anesthetize it and attach it to its tether. Bees were handled under red light, which ensured a dark  
1934 environment to the insects.

### 1935 **Tethering procedure**

1936 Each bee was tethered by means of a 0.06 g steel needle, 0.5 mm in diameter and 40 mm in  
1937 length, which was fixed to the thorax by melted beeswax. The needle was placed within a glass  
1938 cannula, 1 mm in diameter, which was held within a black plastic cylinder, 1 cm in diameter  
1939 and 55 mm in length, which was fixed on a holding frame placed above the treadmill (Fig.  
1940 1A,B). This system allowed the bee to adjust its position in the vertical axis once set on the ball,  
1941 but did not allow rotational movements. The holding frame consisted of a vertical black, plastic  
1942 half frame made of two vertical rectangular supports, 105 mm in length, connected to an upper,  
1943 horizontal rectangular support, 120 mm in length. The latter held the black cylinder in the  
1944 middle (Fig. 1B). After being attached to its tether, each bee was placed on a small (49 mm  
1945 diameter) Styrofoam ball for familiarization to a provisory set-up and provided with 5  $\mu$ l of 1.5  
1946 M sucrose solution. Each bee was held for 3 h in this provisory setup, which was kept in the  
1947 dark and without visual stimulations.

### 1948 **Virtual reality set-up**

1949 The bee was then moved to the VR setup to be trained and tested in a 3D visual environment.  
1950 To establish this environment, we used a custom software developed using the Unity engine  
1951 (version 2018.3.11f1), open-source code available at <https://github.com/G-Lafon/BeeVR>. The  
1952 software updated the position of the bee within the VR every 0.017 s.

1953           The VR apparatus consisted of a spherical Styrofoam ball, which acted as a treadmill  
1954 onto which a stationary bee walked while perceiving an artificial visual landscape displayed in

1955 front of it on a semi-circular screen (Fig. 1A). The ball was 50 mm in diameter and weighted  
1956 1.07 g (Fig. 1B). The ideal weight (M) for spheres holding insects walking on locomotion  
1957 compensators was suggested to be<sup>10</sup>  $M_{\text{sphere}} = 2.5 * M_{\text{animal}}$  , which in case of a honeybee  
1958 weighting in average 0.09 g yields a sphere weight of 0.23 g. Despite the fact that our sphere  
1959 was about 5 times heavier, the bees used in our experiments walked on it without noticeable  
1960 problems. The ball was positioned within a 3D-printed, hollow, cylindrical support (cylinder:  
1961 50 mm high, 59 mm diameter). The cylinder allowed distributing an upwards air flow of 33  
1962 L.min<sup>-1</sup> produced by an AquaOxy 2000 aquarium pump, and released through a small hole at  
1963 the base of the cylindrical support. The Styrofoam ball floated on the resulting air cushion and  
1964 the tethered bee walked on it while remaining stationary. If the bee moves forward, the ball  
1965 moved backwards and if it intended to turn to the right or the left, the ball moved to the left or  
1966 the right, respectively. The ball was white and unmarked (Fig. 1B,C) except in the experiment  
1967 where the influence of the ventral optic flow was tested. In this case, we compared the bees'  
1968 performance using a white ball (Fig. 1C) and a ball displaying a black and white checkered  
1969 pattern made of 7 mm<sup>2</sup> squares (Fig. 1D). The movements of the ball, and thus the walking  
1970 behavior of the bee (i.e. speed, orientation and location in the virtual environment), were  
1971 recorded by two infrared optic-mouse sensors (Logitech M500, 1000 dpi) placed at a distance  
1972 of 7 mm from the sphere and forming an angle of 90° angle relative to each other (i.e. 45° from  
1973 the bee body axis; see Fig. 1A).

1974

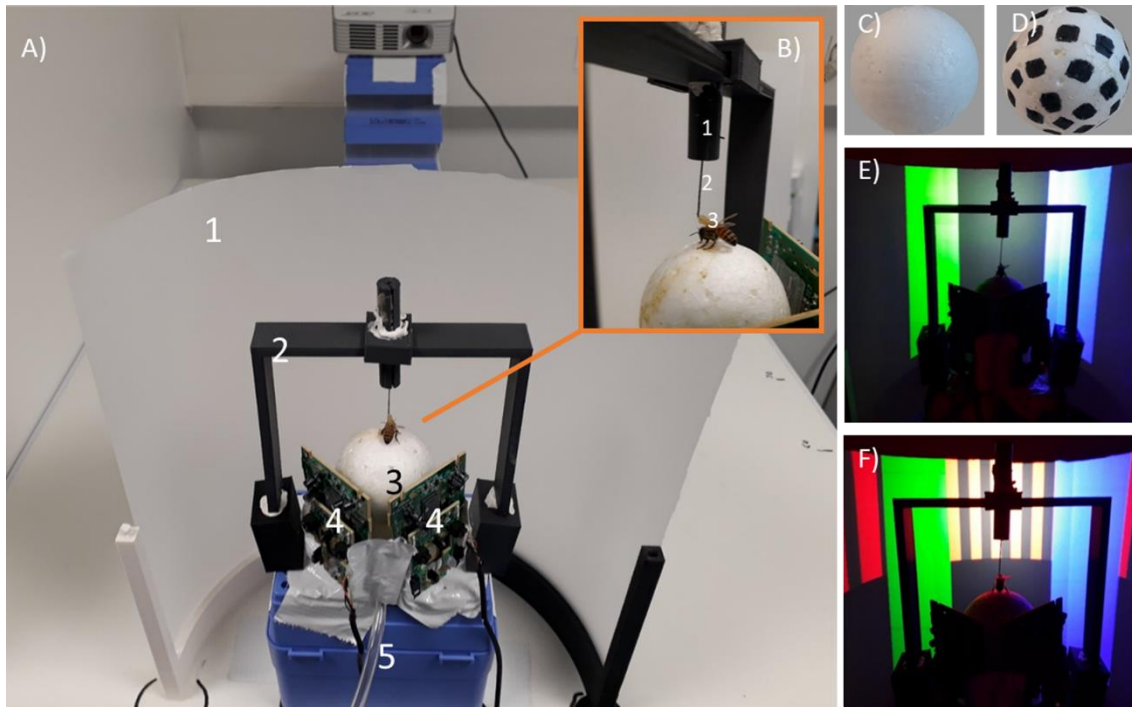

1975

1976 **Figure 1. Experimental setup for 3D virtual-reality (VR) studies in honey bees.** A) Global  
 1977 view of the VR system. 1: Semicircular projection screen made of tracing paper. 2: Holding  
 1978 frame to place the tethered bee on the treadmill. 3: The treadmill was a Styrofoam ball  
 1979 positioned within a cylindrical support (not visible) and floating on an air cushion. 4: Infrared  
 1980 mouse optic sensors allowing to record the displacement of the ball and to reconstruct the bee's  
 1981 trajectory. 5: Air arrival. B) The tethering system. 1: Plastic cylinder held by the holding frame;  
 1982 the cylinder contained a glass cannula into which a steel needle was inserted. 2: The needle was  
 1983 attached to the thorax of the bee. 3: Its curved end was fixed to the thorax by means of melted  
 1984 bee wax. C, D) Two types of Styrofoam balls used for assessing the importance of the ventral  
 1985 optic flow. C) No ventral optic flow provided. D) Ventral optic flow provided. E) Color  
 1986 discrimination learning in the VR setup. The bee had to learn to discriminate a rewarded from  
 1987 a non-rewarded color cuboid. Cuboids were green and blue. In this case color training and  
 1988 testing was set in the '*Transparent Condition*', i.e. no background was provided and the VR  
 1989 display contained only the two colored cuboids on an empty dark background. F) Same as in  
 1990 E) but in this case, the vertical background of the VR arena was covered by a vertical grating  
 1991 made of black and reddish bars. Depending on its movements, the background gave origin to  
 1992 three different conditions: the '*Vertical Grating - Optic Flow Condition*', in which the grating  
 1993 was set in closed loop conditions with respect to the bee movements; the '*Vertical Grating - No  
 1994 Optic Flow Condition*', in which the grating was moved in synchrony with the bee's gaze so  
 1995 that no motion cues could be derived from the background; and the '*Rotating Vertical Grating  
 1996 Condition*', in which the grating was displaced in the anti-clockwise direction across the screen  
 1997 at a constant speed, thus generating a constant optic flow that was independent of the bee's  
 1998 movements.

1999

2000 The ball was positioned in front of a half-cylindrical vertical screen, 268 mm in diameter  
 2001 and 200 mm height, which was placed at 9 cm from the bee. The screen was made of semi-  
 2002 transparent tracing paper, which allowed presentation of a 180° visual environment to the bee  
 2003 (Fig. 1A). The visual environment was projected from behind the screen using a video projector  
 2004 connected to a laptop (Fig. 1A). The video projector was an Acer K135 (Lamp: LED, Maximum  
 2005 Vertical Sync: 120 Hz, Definition: 1280 x 800, Minimum Vertical Sync: 50 Hz, Brightness:  
 2006 600 lumens, Maximum Horizontal Sync: 100.10<sup>3</sup> Hz, Contrast ratio: 10 000:1, Minimum  
 2007 Horizontal Sync: 30.10<sup>3</sup> Hz). The lag between the motion of the bee and the update of the visual  
 2008 surrounding was measured by a high-speed camera at 1000 fps (Canon RX10 mkIII). The VR  
 2009 display started as usual and the hovering motionless ball was quickly moved by hand. A high-  
 2010 speed video containing the ball, the hand and the VR was shot. The number of frames until the  
 2011 background illumination changed were counted by two researchers independently. This  
 2012 procedure yielded a lag value of 18.00 ± 2.53 ms (mean ± S.E.; n =10).

2013

## 2014 Experiment 1: choosing the red intensity for the achromatic black-red background 2015 gratings

2016 Honey bees can perceive a red target in achromatic terms and can discriminate it from black  
 2017 based on its achromatic L-receptor contrast<sup>32,33</sup>. In order to present a vertical, red and black  
 2018 striped background against which a color discrimination had to be achieved, we first performed  
 2019 an experiment to choose the intensity of red that was most appropriate for our background  
 2020 grating. We thus determined the spontaneous phototactic responses of bees towards a vertical  
 2021 red cuboid, which varied in intensity. A red intensity that was high enough to be perceived  
 2022 should induce phototactic attraction.

2023 The cuboid had a 5×5 cm base and 1 m height so that it occupied the entire vertical  
 2024 extent of the screen irrespective of the bee's position (Fig. 2A, left). At the beginning of each  
 2025 trial, it subtended a horizontal visual angle of 6.5° and was positioned either to the left (-50°)  
 2026 or the right (+50°) of the tethered bee. Approaching the cuboid resulted in an expansion of its  
 2027 horizontal extent (1.7°/cm). A choice was recorded when the bee approached the cuboid within  
 2028 an area of 3 cm surrounding its virtual surface and directly faced its center (Fig. 2A, middle and  
 2029 right). Three different groups of bees were tested, each one with a different red intensity (see  
 2030 Fig. S1A): Red 10 (RGB: 26, 0, 0; irradiance: 13 μW/cm<sup>2</sup>; N = 19), Red 50 (RGB: 128, 0, 0;  
 2031 irradiance: 140 μW/cm<sup>2</sup>; N = 19) or Red 100 (RGB: 255, 0, 0; irradiance: 1130 μW/cm<sup>2</sup>; N =

2032 20). Table 1 summarizes the conditions of this Experiment as well as those of the subsequent  
2033 experiments.

2034 Within each group, each bee was subjected to four consecutive tests in extinction  
2035 conditions. During a test, the bee faced the red cuboid on one side, and no stimulus on the  
2036 alternative side. We recorded whether the bee chose the red cuboid or the equivalent empty  
2037 space on the other side (to account for possible stimulus choice from random locomotion paths).  
2038 Each test lasted 60 s and the inter-test interval was 10 s.

## 2039 Experiment 2: the influence of motion cues from a vertical background on color 2040 discrimination

2041 Having chosen a red intensity for the red and black striped vertical background (Red 100; see  
2042 above), we trained bees to discriminate between two vertical colored cuboids, one rewarded  
2043 and the other not (see below). Both cuboids had the same dimensions of the red cuboid  
2044 employed in the previous experiment. One was blue (RGB: 0, 0, 255, with a dominant  
2045 wavelength of 446 nm) and the other green (RGB: 0, 51, 0, with a dominant wavelength at 528  
2046 nm) (Fig. 1E, Fig. 2B left) (see Fig. S1A). Their intensity, measured at the level of the bee eye,  
2047 was 161,000  $\mu\text{W}/\text{cm}^2$  (blue cuboid) and 24 370  $\mu\text{W}/\text{cm}^2$  (green cuboid). These values were  
2048 shown to elicit the same level of spontaneous attraction<sup>12,15</sup>. The cuboids were positioned  
2049 respectively at  $-50^\circ$  and  $+50^\circ$  from the bee's body axis at the beginning of each trial. As in the  
2050 previous experiment, approaching a cuboid within an area of 3 cm surrounding its virtual  
2051 surface followed by direct fixation of its center was recorded as a choice (Fig. 2B middle and  
2052 right).

2053 The background on which the color cuboids were visible was varied to assess the effect  
2054 of background motion cues on visual discrimination learning. Four experimental conditions  
2055 were defined (see Table 1). In the '*Transparent Condition*' (N=24), no background was  
2056 provided and the VR display contained only the two cuboids on an empty dark background  
2057 (Fig. 1E). The residual light from the empty background had a dominant wavelength of 449 nm  
2058 and an irradiance of 38  $\mu\text{W}/\text{cm}^2$ . In the '*Vertical Grating - Optic Flow Condition*' (N=17), the  
2059 walls of the virtual arena were covered by a vertical grating made of black (RGB: 0, 0, 0;  
2060 irradiance: 45  $\mu\text{W}/\text{cm}^2$ ; dominant wavelength 628 nm) and red bars (RGB: 255, 0, 0; irradiance:  
2061 1130  $\mu\text{W}/\text{cm}^2$ ; dominant wavelength 628 nm), each subtending a visual angle of  $6^\circ$  (Fig. 1F).  
2062 Moving forward increased this visual angle by  $0.18^\circ/\text{cm}$ . In the '*Vertical Grating - No Optic*  
2063 *Flow Condition*' (N=17), the same grating made of black and red bars was used but the VR

2064 software moved it in synchrony with the bee's gaze so that no motion cues could be derived  
2065 from the background. Finally, in the '*Rotating Vertical Grating Condition*' (N=17), the same  
2066 black and red grating was displaced in the anti-clockwise direction across the wall at a constant  
2067 speed (12 m/s), thus generating a constant optic flow that was independent of the bee's  
2068 movements.

2069

### 2070 Experiment 3: the influence of motion cues from a ventral background on color 2071 discrimination

2072 In order to test the potential impact of ventral motion cues, we trained bees to discriminate the  
2073 same two vertical colored cuboids used in the previous experiment under two different  
2074 conditions. While the vertical frontal background remained the same as in the *Transparent*  
2075 *Condition* of Experiment 2 (Fig. 1E), the treadmill texture was varied between two groups of  
2076 bees: in one case it was a plain white surface (Fig. 1C; N=29) while in the other case, it was a  
2077 black and white checkered pattern made of 7 mm<sup>2</sup> squares (Fig. 1D; N=38). While the first  
2078 condition did not provide ventral optic flow, the second condition provided it (see Table 1).

2079

### 2080 Training and testing procedure for the Experiments 2 and 3

2081 Bees were trained during 10 trials using a differential conditioning procedure (Fig. 2C) in which  
2082 one of the cuboids (i.e. one of the two colors, green or blue) was rewarded with 1.5 M sucrose  
2083 solution (the appetitive conditioned stimulus or CS+) while the other cuboid displaying the  
2084 alternative color (the aversive conditioned stimulus or CS-) was associated with either 60 mM  
2085 quinine (Experiment 2)<sup>34</sup> or 3 M NaCl solution<sup>35,36</sup> (Experiment 3). The latter was used to  
2086 increase the penalty for incorrect choices<sup>37</sup>.

2087 At the beginning of the experiment, bees were presented with a dark screen for 60 s.  
2088 During training trials, each bee faced the virtual environment with the two cuboids in front of  
2089 it. The bee had to learn to choose the CS+ cuboid by walking towards it and centering it on the  
2090 screen. Training was balanced in terms of color contingencies (i.e. blue and green equally  
2091 rewarded across bees) based on a random assignment by the VR software. If the bee reached  
2092 the CS+ within an area of 3 cm in the virtual environment (i.e. the chosen cuboid subtended a  
2093 horizontal visual angle of 53°) and centered it in its front, the screen was locked on that image  
2094 for 8 s (Fig. 2B). This allowed the delivery of sucrose solution in case of a correct choice, or of

2095 quinine or NaCl in case of an incorrect choice. Solutions were delivered for 3 s by the  
2096 experimenter who sat behind the bee and used a toothpick to this end. The toothpick contacted  
2097 first the antennae and then the mouthparts while the screen was locked on the visual image  
2098 fixated by the bee.

2099 Each training trial lasted until the bee chose one of both stimuli or until a maximum of  
2100 60 s (no choice). Thus, a single choice (or a no choice) was recorded during each training trial.  
2101 Trials were separated by an inter-trial interval of 60 s during which the dark screen was  
2102 presented. The bees that were unable to choose a stimulus in at least 5 trials were excluded from  
2103 the analysis. From 216 bees trained in the Second Experiment, 75 were kept for analysis  
2104 (~35%). From 272 bees trained in the Third Experiment, 67 bees were kept for analysis (~25%).

2105 After the last training trial, each bee was subjected to a non-reinforced test (Fig. 2C) that  
2106 contrary to training trials had a fixed duration of 60 s. During this test, two variables were  
2107 recorded: the first choice (as defined above) and the time spent fixating the rewarded and the  
2108 non-rewarded stimulus. Both variables have been used in prior works performed in our VR  
2109 setup to characterize test performances as they may reveal different aspects of behavioral  
2110 performances<sup>12,13,15</sup>. Fixation time (s) was defined as the time spent by each cuboid at the center  
2111 of the screen ( $\pm 2.5$  mm) where it was brought by the bee's motor actions. We used a ray-casting  
2112 approach to determine if the object was there and recorded collisions between a ray following  
2113 the forward vector of the bee and the center of the object.

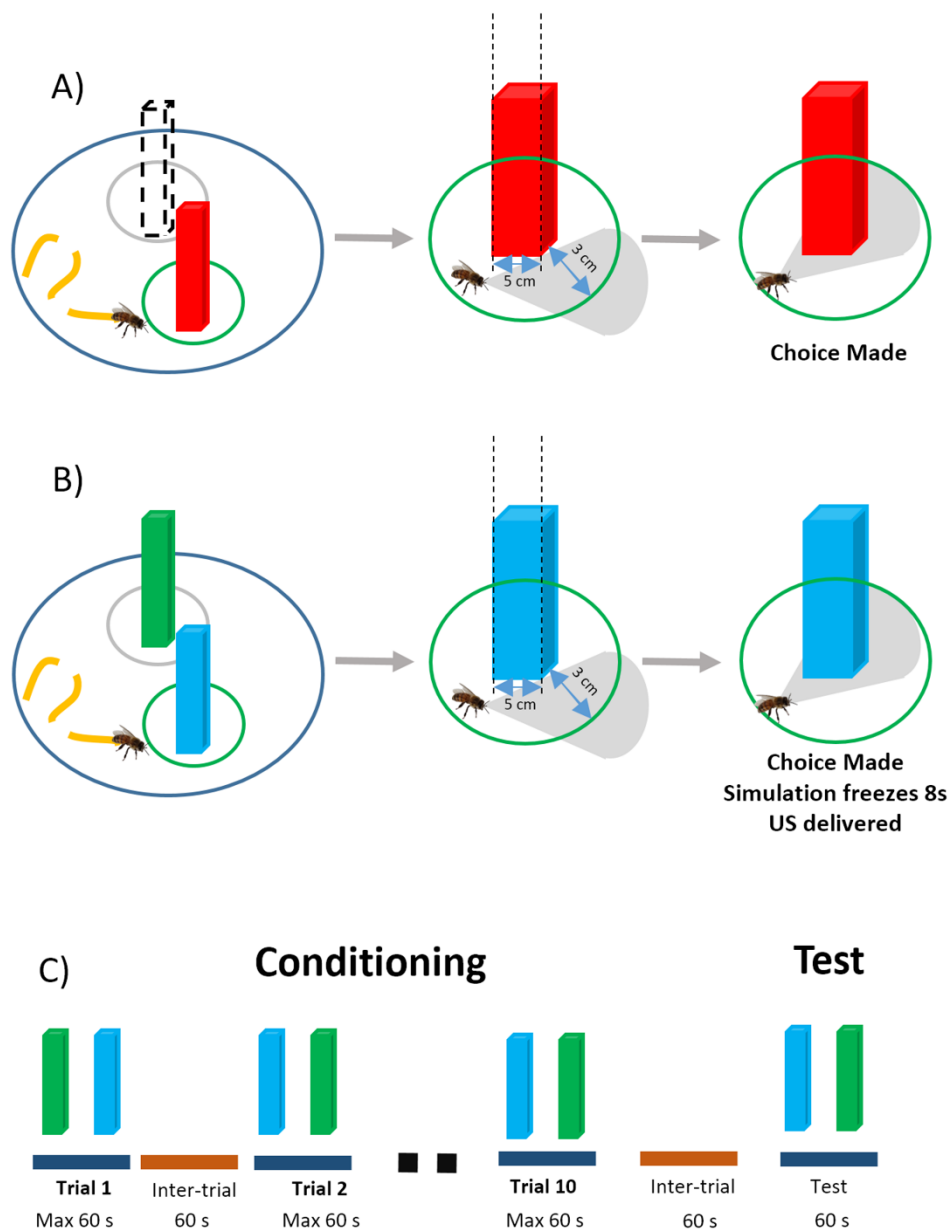

2114

2115 **Figure 2. Choice and discrimination learning tasks in the VR setup. A) Experiment 1:**  
 2116 Quantification of the spontaneous phototactic responses of bees towards a red cuboid against  
 2117 the absence of an equivalent stimulus in the symmetric position (dashed cuboid). Choice of the  
 2118 red cuboid was recorded if the bee reached a virtual area of a radius of 3 cm centered on the  
 2119 cuboid and fixed it frontally. **B) Experiments 2 and 3:** Color discrimination learning with a  
 2120 green and a blue cuboid. One cuboid was rewarded with sucrose solution and the other punished  
 2121 with either quinine solution (Experiment 2) or saline solution (Experiment 3) delivered by the  
 2122 experimenter. A choice was recorded when the bee reached an area of a radius of 3 cm centered  
 2123 on the cuboid and fixed it frontally. The cuboid image was then frozen during 8 s and the  
 2124 corresponding reinforcement (US) was delivered. **C) Experimental schedule of color learning**  
 2125 **experiments (Experiments 2 and 3).** Bees were trained along 10 conditioning trials that lasted  
 2126 a maximum of 1 min and that were spaced by 1 min (intertrial interval). After the end of  
 2127 conditioning, and following an additional interval of 1 min, bees were tested in extinction  
 2128 conditions with the two colored cuboids during 1 min.

2129

Experiment	Condition Training - Test	Background	N
<b>Experiment 1</b> <b>Choice of Red Intensity</b>	<i>Red 10</i> No Training –Test: Red 10 vs. Nothing	Frontal Black	19
	<i>Red 50</i> No Training –Test: Red 50 vs. Nothing	Frontal Black	19
	<i>Red 100</i> No Training –Test: Red 100 vs. Nothing	Frontal Black	20
<b>Experiment 2</b> <b>Frontal Motion Cues</b>	<i>Transparent Condition</i> Training & Test: Blue vs. Green	Frontal Black	24
	<i>Vertical Grating - Optic Flow Condition</i> Training & Test: Blue vs. Green	Frontal: Black & Red Vertical Stripes Closed Loop	17
	<i>Vertical Grating - No Optic Flow Condition</i> Training & Test: Blue vs. Green	Frontal: Black & Red Vertical Stripes Fixed to the Bee's Gaze	17
	<i>Rotating Vertical Grating Condition</i> Training & Test: Blue vs. Green	Frontal: Black & Red Vertical Stripes Constantly Rotating	17
<b>Experiment 3</b> <b>Ventral Motion Cues</b>	<i>No Ventral Optic Flow Condition</i> Training & Test: Blue vs. Green	Frontal: Black Ventral: None (White Treadmill)	29
	<i>Ventral Optic Flow Condition</i> Training & Test: Blue vs. Green	Frontal Black Ventral: (Black and White Treadmill)	38

2130 **Table 1:** Summary of the experimental conditions provided in Experiments 1 to 3. N: sample  
2131 size of each condition.

### 2132 **Statistical analysis**

2133 Statistical analyses were performed using R software<sup>38</sup>. In Experiment 1 (red perception), the  
2134 first choice of the bees in each test was categorized according to three mutually exclusive  
2135 categories: Red Stimulus (Red), No Stimulus (NS: choice of the area symmetric to the stimulus  
2136 position) and no choice (NC). Individual choices were translated into a binomial format (0 or  
2137 1) within each category. For instance, a bee choosing the red cuboid was recorded as (1, 0, 0)  
2138 for a choice of the red stimulus, choice of the no stimulus and NC, respectively. In Experiments  
2139 2 and 3, the first choice in each trial and test was categorized as choice of the CS+, choice of  
2140 the CS- or no choice (NC). Thus, a bee choosing the CS+ was recorded as (1, 0, 0) for choice  
2141 of the CS+, choice of the CS- and NC, respectively. Data were bootstrapped to plot the  
2142 proportion of bees in each category with their corresponding 95 % confidence interval.  
2143 Performances were analysed using generalized mixed linear models (GLMM) with a binomial  
2144 error structure-logit-link function (glmer function of R package lme4)<sup>39</sup>. The independent  
2145 variables (fixed factors) were the experimental group (*Condition*), the trial number (*Trial*;  
2146 Experiments 2 and 3), the choice category (*Choice*) and the color of the CS+ when applicable  
2147 (*Color*: Blue or Green). *Bee ID* was included as a random factor to account for the repeated-  
2148 measure design. Several models were run by testing interactions between factors and by  
2149 dropping each factor subsequently to select the model with the highest explanatory power (i.e.

2150 the lowest AIC value). P-values for each factor or interaction were obtained by comparing  
2151 models. The Tukey method was used for multiple comparisons within the selected model; z  
2152 values are reported for these analyses. For all experiments, the modeling results are reported in  
2153 Tables S1 to S3 in Supplementary Information. During the tests of Experiments 2 and 3, we  
2154 also recorded the time spent fixating the test alternatives (CS+ vs. CS-). Time values were  
2155 compared using a Wilcoxon signed rank test.

2156         For the acquisition trials, we recorded motor variables such as the total distance walked  
2157 during a trial, the walking speed, and the tortuosity of the trajectories. Tortuosity was calculated  
2158 as the ratio between the total distance walked and the distance between the first and the last  
2159 point of the trajectory connected by an imaginary straight line. When the ratio was 1, or close  
2160 to 1, trajectories were straightforward while higher values corresponded to sinuous trajectories.  
2161 In addition, we analyzed the latency to make a choice starting from the beginning of a trial to  
2162 the moment in which a choice (either for the CS+ or the CS-) was recorded. NC data were  
2163 excluded from the latency analysis. The analysis of these continuous variables was done using  
2164 a linear mixed model (lmer function) in which the individual identity (*Bee ID*) was a random  
2165 factor and the experimental condition (*Condition*) and trial number (*Trial*) were fixed factors.

2166         For each experimental condition, we represented the bees' cumulative trajectories (CS+  
2167 choosing and CS- choosing bees) in terms of heat maps, which show the cumulative coordinates  
2168 occupied by the bees either during the ten training trials or during the non-reinforced test to  
2169 which they were subjected. Coordinates were binned into 1 cm<sup>2</sup>. Warmer colors depict locations  
2170 more frequently occupied (see color bar). The highest frequency is cut down to 10 % of the  
2171 maximum on the color bar. This was done to decrease the excessive occupancy frequency of  
2172 the starting point at the expense of other locations, given that it was the same for all bees. While  
2173 the side of the rewarded stimulus was randomized, it was placed arbitrarily on the left in the  
2174 heat maps.

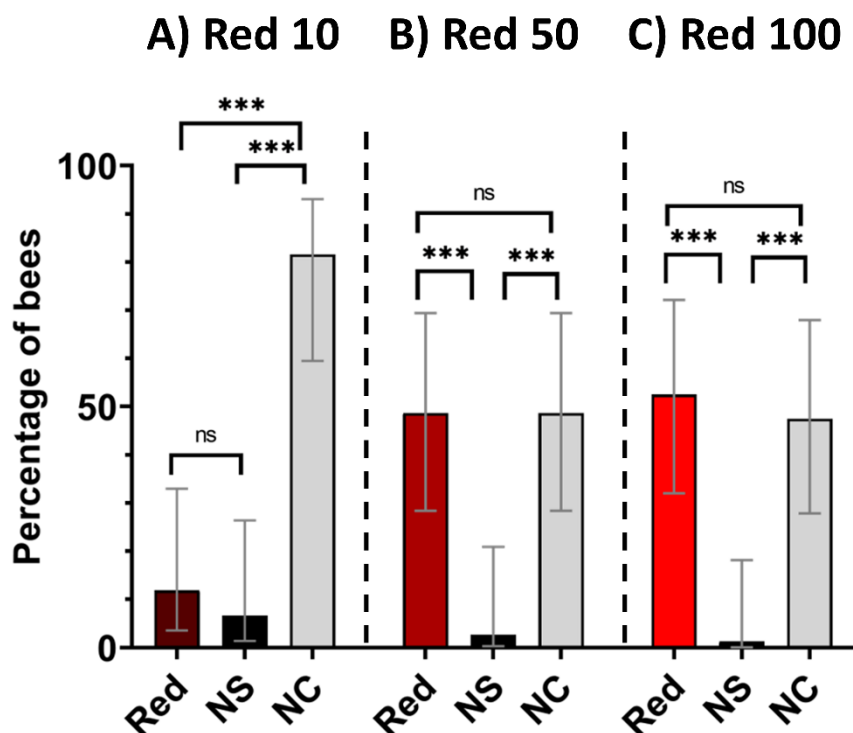

2175

2176 **Figure 3. Experiment 1 - Choosing the red intensity for the achromatic black and red**  
 2177 **background.** Quantification of the spontaneous phototactic responses of bees towards a red  
 2178 cuboid (see Fig. 2A). Three different intensities were assayed, each with a different group of  
 2179 bees: Red 10 (RGB: 26, 0, 0; irradiance: 13  $\mu\text{W}/\text{cm}^2$ ; N = 19), Red 50 (RGB: 128, 0, 0;  
 2180 irradiance: 140  $\mu\text{W}/\text{cm}^2$ ; N = 19) and Red 100 (RGB: 255, 0, 0; irradiance: 1130  $\mu\text{W}/\text{cm}^2$ ; N =  
 2181 20). For each intensity, the figure represents the pooled performance of four consecutive  
 2182 extinction tests in which the spontaneous attraction towards the red cuboid ('Red') was  
 2183 quantified. 'NS' (no stimulus) represents the choice of an equivalent empty area in the VR arena  
 2184 that was opposite to the red cuboid (see Fig. 2A). NC: no choice. Both the Red-50 and the Red-  
 2185 100 intensities were sufficient to render the red stimulus detectable for honeybees. For  
 2186 subsequent experiments, the Red 100 intensity was chosen.

## 2187 Results

### 2188 Experiment 1: choosing the red intensity for the achromatic black and red background

2189 In a first experiment, we determined the spontaneous phototactic responses of bees towards a  
 2190 red cuboid (dominant wavelength 628 nm) varying in intensity. Using different groups of bees,  
 2191 we tested three different intensities to define the one that would be sufficient to induce  
 2192 phototactic attraction: Red 10 (RGB: 26, 0, 0; irradiance: 13  $\mu\text{W}/\text{cm}^2$ ), Red 50 (RGB: 128, 0,  
 2193 0; irradiance: 140  $\mu\text{W}/\text{cm}^2$ ) and Red 100 (RGB: 255, 0, 0; irradiance: 1130  $\mu\text{W}/\text{cm}^2$ ). Each bee  
 2194 was tested along four consecutive tests with the same intensity. The model that best fitted the  
 2195 data included an interaction between the red intensity and the bees' choice (*Choice\*Intensity*:

2196  $\chi^2 = 65.48$ , df: 4,  $p < 0.001$ ). There was no significant effect of the test sequence on the bees'  
 2197 choices (*Test*:  $\chi^2 = 0.002$ , df:1,  $p = 0.97$ ). Thus, we pooled the data of the four tests and  
 2198 represented for each intensity the percentage of bees within each category (Red, No Stimulus  
 2199 and No Choice; Fig. 3).

2200 In the Red 10 condition (Fig. 3A; N = 19 bees), the bees did not prefer the red cuboid to  
 2201 the alternative symmetrical area displaying no stimulus (Red 10 vs. NS: 11.8% vs. 6.8% of  
 2202 choices,  $z = 1.11$ ,  $p = 0.27$ ). Most of the bees did not choose in this condition (81.6% of the  
 2203 cases: NC vs. Red 10:  $z = 7.56$ ,  $p < 0.0001$ ; NC vs. NS:  $z = 7.54$ ,  $p < 0.0001$ ). By contrast,  
 2204 both in the Red 50 (Fig. 3B; N = 19) and in the Red 100 condition (Fig. 3C; N = 20), bees  
 2205 preferred the red stimulus to the equivalent area displaying no stimulus (Red 50 vs. NS: 48.7%  
 2206 vs. 2.6%,  $z = 4.73$ ,  $p < 0.0001$ ; Red 100 vs. NS: 52.5% vs. 1.3%,  $z = 4.34$ ,  $p < 0.0001$ ). The  
 2207 percentage of bees not choosing remained high and similar to that of bees choosing the red  
 2208 cuboid (Red 50 vs. NC:  $z = 0.000$ ,  $p = 1.00$ ; Red 100 vs. NC:  $z = 0.58$ ;  $p = 0.53$ ). For both  
 2209 intensities, the proportion of non-choosing bees was significantly higher than the choice of the  
 2210 absence of stimulus (Red 50 vs. NS: 48.7% vs. 48.6%,  $z = 4.73$ ,  $p < 0.0001$ ; Red 100 vs. NS:  
 2211 52.5% vs. 47.5%,  $z = 4.14$ ,  $p < 0.0001$ ). These results indicate that both the Red-50 and the Red-  
 2212 100 intensities were sufficient to render the red stimulus detectable for honeybees. We therefore  
 2213 chose the Red-100 intensity for the red-and-black gratings used in the subsequent experiment  
 2214 as it was the more salient stimulus from the two that were detectable by the bees. We were  
 2215 confident that Red 100 would not induce higher phototaxis than Red 50 as no differences in  
 2216 attraction existed between the cuboids displaying these two lights (compare Fig. 3 B and 3 C).

2217

## 2218 Experiment 2: the influence of motion cues from a vertical frontal background on color 2219 discrimination

2220 Four different frontal background conditions were used to assess the effect of motion cues from  
 2221 the background during color discrimination learning. In the '*Transparent Condition*' (N = 24  
 2222 bees), the blue and green cuboids were displayed against a uniform dark background. In the  
 2223 '*Vertical Grating - Optic Flow Condition*' (N = 17 bees), the cuboids were presented against a  
 2224 red-and-black vertical grating, which was coupled to the bee's movements (closed-loop  
 2225 conditions). In the '*Vertical Grating - No Optic Flow Condition*' (N = 17 bees), the cuboids  
 2226 were displayed against the same red-and-black grating but motion cues from the background  
 2227 were suppressed by keeping it constantly fixed to the bee's gaze. Finally, in the '*Rotating*

2228 *Vertical Grating Condition*' (N = 17 bees), the cuboids were shown against the same red-and-  
2229 black grating, which was rotated counterclockwise around the virtual arena at a constant speed,  
2230 thus generating a constant optic flow even when the bee did not move.

### 2231 **Discrimination learning during training**

2232 Figure 4A-D shows the learning curves of the four groups of bees trained to discriminate the  
2233 green from the blue cuboid under different background conditions and the cumulative heat maps  
2234 displaying the locations of the bees in their trajectories during the ten acquisition trials.  
2235 Learning curves were obtained by recording the percentage of bees choosing correctly the CS+  
2236 or the CS- in their first choice, or not choosing any stimulus (NC) during each trial. The best  
2237 explanatory model of the acquisition performance included a three-way interaction between the  
2238 condition, the trial number and the bees' choice ( $\chi^2 = 50.11$ , df:15,  $p < 0.001$ ) but no effect of  
2239 the nature of the CS+ was found (blue or green:  $\chi^2 = 0.000$ , df:1,  $p = 1$ ). For each background  
2240 condition, data were thus represented as a CS+ vs. a CS- discrimination irrespective of color  
2241 identity. In the heat maps, the rewarded cuboid is represented on the left side although its side  
2242 was randomized along the training sequence.

2243         When no grating was present in the background and the colored cuboids were displayed  
2244 against a dark homogeneous background (*'Transparent Condition'*; Fig. 4A), bees learned to  
2245 respond more to the CS+ than to the CS-. The interaction between trial number and bee choices  
2246 was significant ( $\chi^2 = 7.99$ , df:2,  $p = 0.02$ ). In the course of the 10 conditioning trials, the  
2247 percentages of bees responding to the CS+ and that of bees responding to the CS- evolved  
2248 differently ( $z = 2.51$ ,  $p = 0.01$ ), thus showing successful discrimination learning. Moreover, the  
2249 dynamic of CS+ responding bees was also significantly different from that of the non-  
2250 responding (NC) bees ( $z = 2.17$ ,  $p = 0.03$ ) while the difference between the dynamic of the CS-  
2251 responding bees and the NC bees was not different ( $z = 0.13$ ,  $p = 0.9$ ). In the corresponding  
2252 cumulative heat map, a clear V shape is visible, indicating that the bees did interact equally  
2253 with both sides in the VR and walked towards the cuboids.

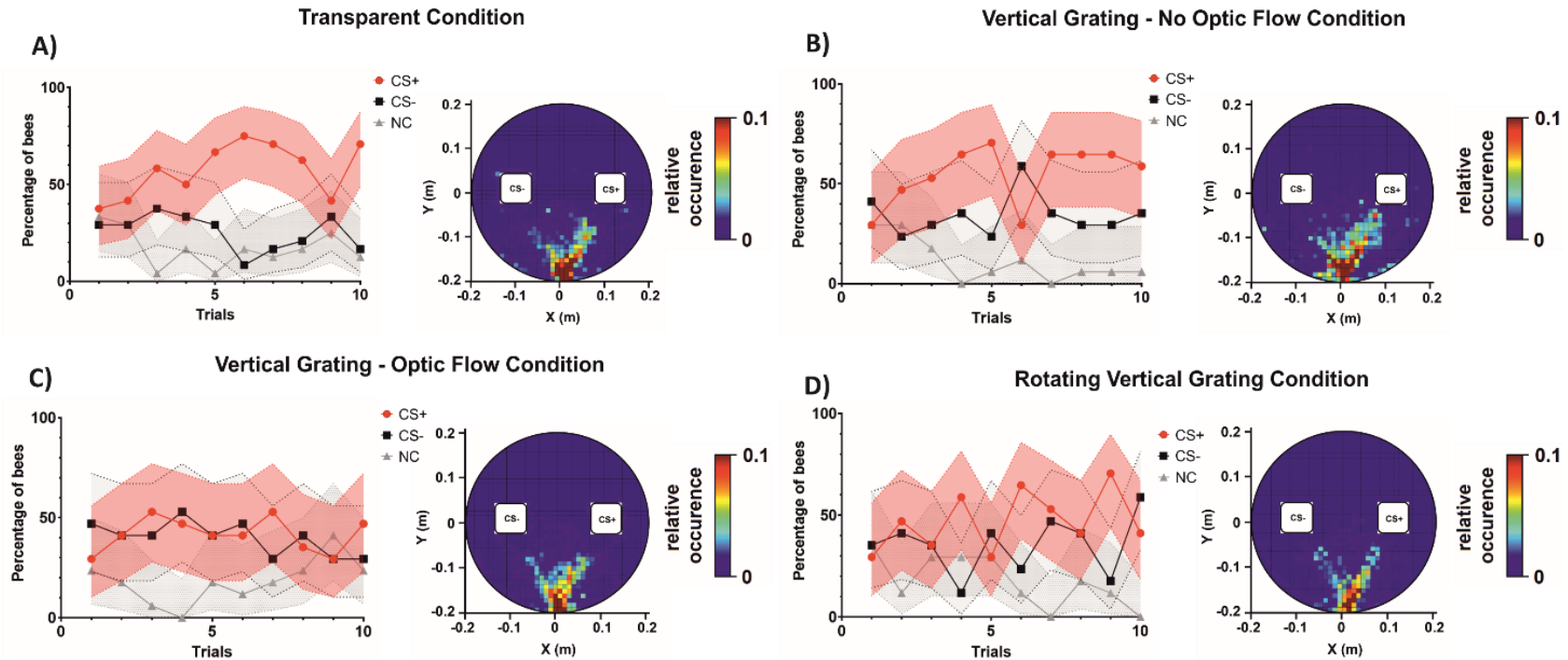

2254

2255 **Figure 4. Acquisition performances in a color discrimination learning task under four different background conditions.** Each panel shows  
 2256 on the left the acquisition curves in terms of the percentage of bees responding to the CS+ (red), to the CS- (black) or not making any choice (NC;  
 2257 gray) during the ten conditioning trials. The pink, light gray and gray areas around the curves represent the 95% confidence interval of CS+, CS-  
 2258 choices and NC, respectively. On the right of each panel, a heat map shows the cumulative coordinates occupied by the bees trained under each  
 2259 background condition during the ten training trials. Coordinates were binned into 1 cm<sup>2</sup>. Warmer colors depict locations more frequently occupied  
 2260 (see color bar). The highest frequency is cut down to 10 % of the maximum on the color bar. While the side of the rewarded stimulus was  
 2261 randomized along conditioning trials, it was placed arbitrarily on the right in the heat maps. **A)** In the ‘*Transparent Condition*’ (N = 24), the blue  
 2262 and green cuboids were displayed against a dark background. **B)** In the ‘*Vertical Grating - No Optic Flow Condition*’ (N = 17), the cuboids were  
 2263 displayed against the same red-and-black grating but motion cues from the background were suppressed by keeping it constantly fixed to the bee’s  
 2264 gaze. **C)** In the ‘*Vertical Grating –Optic Flow Condition*’ (N = 17), the cuboids were presented against a red-and-black vertical grating, which was  
 2265 coupled to the bee’s movements (closed-loop conditions). **D)** In the ‘*Rotating Vertical Grating Condition*’ (N = 17), the cuboids were shown  
 2266 against the same red-and-black grating, which was rotated counterclockwise around the virtual arena at a constant speed, thus generating a constant  
 2267 optic flow even when the bee did not move.

2268

2269           When the red-and-black grating was moved in synchrony with the bee's gaze so that no  
2270 motion cues could be derived from the background ('*Vertical Grating - No Optic Flow*  
2271 *Condition*'; Fig. 4B), bees did not modify significantly their stimulus choice along trials. There  
2272 was a significant interaction between trial number and bee choices ( $\chi^2 = 13.6$ ,  $df:2$ ,  $p = 0.001$ )  
2273 but only because of a difference in the dynamic of the NC bees compared to other two categories  
2274 (NC vs. CS+:  $z = 3.44$ ,  $p < 0.001$ ; NC vs. CS-:  $z = 2.60$ ,  $p < 0.001$ ). Although the CS+ and the  
2275 CS- curves seem to indicate color discrimination, no differences between the dynamics of the  
2276 percentages CS+ and CS- choosing bees could be detected ( $z = 1.20$ ,  $p = 0.23$ ), probably because  
2277 of the high overlap in confidence intervals of these curves. The cumulative heat map  
2278 representing the locations of the bees during their training trajectories shows that, as in the  
2279 previous two conditions, bees walked and interacted equally with both sides in the VR.

2280           In the '*Vertical Grating - Optic Flow Condition*' (Fig. 4C), the closed loop conditions  
2281 included both the cuboids and the background grating, i.e. the bees' movements translated and  
2282 expanded not only the cuboids but also the background grating accordingly. The interaction  
2283 between trial number and bee choices was not significant in this case ( $\chi^2 = 5.16$ ,  $df:2$ ,  $p = 0.08$ ).  
2284 Contrarily to the previous condition, bees were unable to learn the difference between the CS+  
2285 and the CS- as no improvement could be detected along the 10 training trials ( $z = 0.33$ ,  $p =$   
2286  $0.74$ ). Only the dynamics of the non-responding bees was significantly lower than that of bees  
2287 selecting either the CS+ ( $z = 4.63$ ,  $p < 0.001$ ) or the CS- ( $z = 4.33$ ,  $p < 0.001$ ). The cumulative  
2288 heat map representing the locations of the bees during their training trajectories shows that, as  
2289 in the previous condition, bees walked towards the cuboids. This result indicates that despite  
2290 interacting with the cuboids, bees had their color learning impaired by the addition of motion  
2291 cues from the background.

2292           Finally, in the '*Rotating Vertical Grating Condition*' (Fig. 4D) in which the black-and-  
2293 red grating was displaced at a constant speed irrespective of the bee movements and gaze, a  
2294 similar pattern than for the '*No Optic Flow Condition*' was observed. A significant interaction  
2295 between trial number and bee choices was found ( $\chi^2 = 11.21$ ,  $df:2$ ,  $p = 0.004$ ). Yet, it was again  
2296 due to differences in the dynamic of the percentage of NC bees vs. the percentages of CS+ and  
2297 CS- bees (NC vs. CS+:  $z = 3.11$ ,  $p = 0.002$ ; NC vs. CS-:  $z = 2.71$ ,  $p = 0.007$ ). The percentage of  
2298 bees choosing the CS+ and that of bees choosing the CS- did not evolve differently ( $z = 0.44$ ;  
2299  $p = 0.66$ ). In this condition, the cumulative heat map shows that bees also walked and interacted  
2300 equally with the two cuboid sides along trials.

## 2301 **Motor and temporal components of bee trajectories during training**

2302 We analyzed if and how motion cues from the background affected the displacement of bees  
2303 during the training trials in our four background conditions (Fig. 5). To this end, we quantified  
2304 the distance walked, the walking speed and the tortuosity of the trajectories (ratio between the  
2305 total distance walked and the straight line connecting the first and the last point of the  
2306 trajectory). We also measured the choice latency in each trial, i.e. the time required to choose a  
2307 cuboid within a trial.

2308         The distance walked (Fig. 5A) increased slightly, yet significantly, over trials (*Trial*:  $\chi^2$   
2309 = 6.86, df:1,  $p = 0.009$ ) but was not significantly affected by the background condition  
2310 (*Condition*:  $\chi^2 = 5.34$ , df:3,  $p = 0.15$ ). The walking speed (Fig. 5B) also increased during  
2311 successive trials (*Trial*:  $\chi^2 = 172.9$ , df:1,  $p < 0.001$ ) and revealed a significant interaction with  
2312 the background condition (*Trial\*Condition*:  $\chi^2 = 19.3$ , df:3,  $p < 0.001$ ), which was introduced  
2313 by the *Optic Flow Condition*. In this case, bees decreased their speed at the end of the training,  
2314 so that a significant difference was detected against the other background conditions  
2315 (*Trial\*Condition*: '*Optic Flow*' vs. '*Transparent*':  $t = 3.64$ ,  $p < 0.001$ , '*Optic Flow*' vs. '*No Optic*  
2316 '*Flow*':  $t = 3.79$ ,  $p < 0.001$  and '*Optic Flow*' vs. '*Rotating Grating*':  $t = 3.47$ ,  $p < 0.001$ ). This  
2317 decrease was concomitant with an increase in the proportion of bees not choosing (Fig. 4B) so  
2318 that it may reveal a reduction in motivation at the end of training in this background condition.  
2319 The tortuosity of the trajectories (Fig. 5C) was neither affected by the succession of trials nor  
2320 by the background condition (*Trial*:  $\chi^2 = 0.17$ , df:1,  $p = 0.68$ ; *Condition*:  $\chi^2 = 3.62$ , df:3,  $p =$   
2321  $0.31$ ), thus confirming that the structure of motor patterns was similar across the background  
2322 conditions. Finally, the analysis of choice latency (Fig. 5D) showed a significant decrease along  
2323 trials (*Trial*:  $\chi^2 = 21.85$ , df:1,  $p < 0.001$ ; Fig. 5D), suggesting an improvement in the bee's  
2324 capacity to navigate in the VR environment. This evolution was independent of the background  
2325 displayed (*Condition*:  $\chi^2 = 1.67$ , df:3,  $p = 0.65$ ) but a tendency towards larger latencies was  
2326 observed for the '*Optic Flow Condition*'.

2327

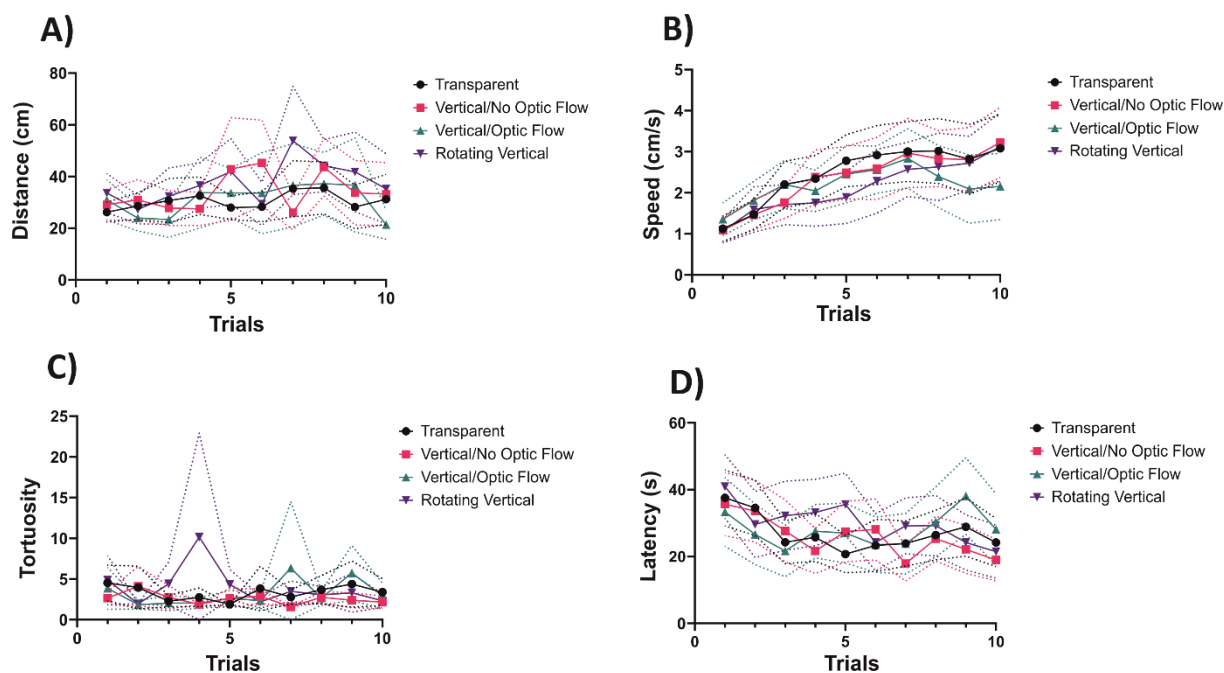

2328

2329 **Figure 5. Motor and temporal components of bee trajectories during the acquisition trials.**  
 2330 For each background condition, the evolution of **A)** the distance walked, **B)** the walking speed,  
 2331 **C)** the tortuosity and **D)** the choice latency during training trials is shown. The tortuosity was  
 2332 the ratio between the total distance walked and the straight line connecting the first and the last  
 2333 point of the trajectory during a training trial. *Transparent Condition* (N = 24), *Vertical Grating*  
 2334 *- Optic Flow Condition* (N = 17), *Vertical Grating - No Optic Flow Condition* (N = 17),  
 2335 *Rotating Vertical Grating Condition* (N = 17). The dashed lines above and below the curves  
 2336 represent the 95% confidence interval.

2337

## 2338 Test Performance

2339 After the end of training, each bee was subjected to a test in which the green and the blue  
 2340 cuboids were presented in extinction conditions (no reinforcement provided). We recorded the  
 2341 percentage of bees choosing correctly the CS+ or the CS- in their first choice, or not choosing  
 2342 (NC) and the time spent fixating the CS+ and the CS- (Fig. 6).

2343 The rewarded color did not affect the first choice during the test (*Color*:  $\chi^2 = 0$ , df:1, p  
 2344 = 1), so that performances could be analyzed irrespective of color identity within each  
 2345 background condition. Only under the *Transparent Condition* (Fig. 6A), the difference  
 2346 between the percentages of CS+ and CS- responding bees was significant (CS+ vs CS-, z =  
 2347 2.33, p = 0.02). The difference between the CS+ responding bees and the NC bees was also  
 2348 significant (CS+ vs. NC: z = 2.83, p = 0.005). On the contrary, no difference was detected  
 2349 between the CS- responding bees and the NC bees (CS- vs. NC: z = 0.71, p = 0.48). For the  
 2350 other three background conditions, no significant differences were detected between the

2351 percentage of bees choosing the CS+ or the CS- (Fig. 6B: '*Optic Flow Condition*'; CS+ vs CS-  
 2352 ,  $z = 1.41$ ,  $p = 0.16$ ; Fig. 6C: '*No Optic Flow Condition*'; CS+ vs CS-,  $z = 1.0$ ,  $p = 0.30$ ; Fig.  
 2353 6D: '*Rotating Grating Condition*'; CS+ vs CS-,  $z = 0.4$ ,  $p = 0.7$ ). The comparisons with NC  
 2354 bees in these three conditions were all non-significant except in the '*No Optic Flow Condition*'  
 2355 where CS+ responding bees and NC bees differed significantly (Fig. 6B: '*Optic Flow*  
 2356 '*Condition*'; CS+ vs. NC:  $z = 1.05$ ,  $p = 0.30$ ; CS- vs. NC:  $z = 0.38$ ,  $p = 0.70$ ; Fig. 6C: '*No Optic*  
 2357 '*Flow Condition*'; CS+ vs. NC:  $z = 2.38$ ,  $p = 0.02$ ; CS- vs. NC:  $z = 1.55$ ,  $p = 0.12$ ; Fig. 6D:  
 2358 '*Rotating Grating Condition*'; CS+ vs. NC:  $z = -1.09$ ,  $p = 0.28$ ; CS- vs. NC:  $z = -0.75$ ,  $p = 0.45$ ).  
 2359 Overall, the first-choice data show that a significant discrimination between the CS+ and the  
 2360 CS- occurred in the '*Transparent Condition*', i.e. in the total absence of background  
 2361 information.

2362 The analysis of the fixation time confirmed and extended this conclusion (Fig. 6 E-H).  
 2363 Again, no discrimination learning was observed for the conditions in which motion cues were  
 2364 available from the background; bees spent the same amount of time fixating the CS+ and the  
 2365 CS- both in the '*Optic Flow Condition*' (Fig. 6F; Wilcoxon U rank Test:  $V = 69$ ,  $p = 0.63$ ) and  
 2366 in the '*Rotating Grating Condition*' (Fig. 6H;  $V = 83$ ,  $p = 0.78$ ). On the contrary, and consistent  
 2367 with the analysis based on the 1<sup>st</sup> choice, bees in the '*Transparent Condition*' learned the  
 2368 discrimination between the CS+ and the CS- as they spent more time fixating the rewarded  
 2369 color than the non-rewarded one (Fig. 6E;  $V = 203$ ,  $p = 0.049$ ). Interestingly, a significant  
 2370 discrimination was also observed for the '*No Optic Flow Condition*' (Fig. 6G;  $V = 128$ ,  $p =$   
 2371  $0.012$ ), a condition for which the 1<sup>st</sup> choice did not reveal significant differences. This result  
 2372 indicates that the reduction of motion cues inherent to the '*No Optic Flow Condition*' also  
 2373 favored the occurrence of color learning, in agreement with what was observed for the  
 2374 '*Transparent Condition*'.

2375 The heat maps displaying the cumulative locations occupied by the bees' trajectories  
 2376 during the entire test are shown in the bottom of Fig. 6. In these maps, the CS+ is displayed on  
 2377 the right by convention. In the '*Transparent Condition*' (Fig. 6A), besides choosing  
 2378 significantly more the correct cuboid upon their first choice and spending more time fixating it,  
 2379 bees consistently walked towards the cuboids and inspected them. This tendency was not visible  
 2380 in the conditions in which motion cues were available from the background (Fig. 6B: '*Optic*  
 2381 '*Flow Condition*' and Fig. 6D: '*Rotating Grating Condition*'), thus showing the impairment of  
 2382 performances induced by these cues. In the '*No Optic Flow Condition*' (Fig. 6C), bees walked  
 2383 towards the cuboids and their choice was slightly biased towards the correct color, in

2384 accordance with the longer fixation time elicited by this color. Overall, these results reveal a  
2385 negative influence of motion cues from the vertical background on visual-discrimination  
2386 learning under VR conditions.

2387

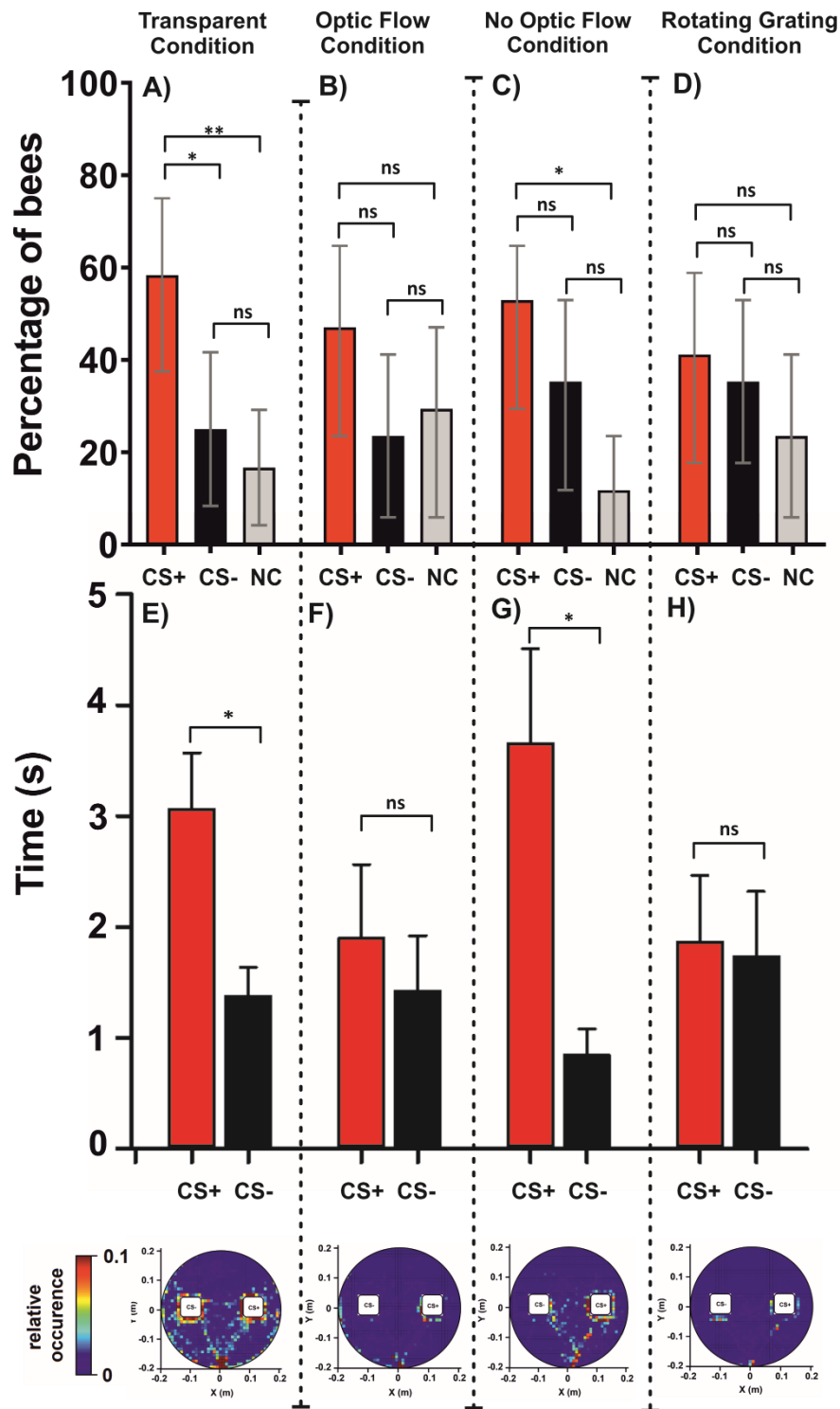

2388

2389 **Figure 6. Test performances (1<sup>st</sup> choice and fixation time) in a color discrimination**  
 2390 **learning task under four different background conditions. Panels A-D refer to the 1<sup>st</sup> choice**  
 2391 **and show the percentage of bees responding to the CS+ (red), to the CS- (black) or not making**  
 2392 **any choice (NC; gray) during a retention test performed in extinction conditions after a 10-trial**  
 2393 **training. Error bars indicate 95% confidence intervals. \*:  $p < 0.05$ ; \*\*:  $p < 0.01$ ; ns: non-**  
 2394 **significant. A) In the ‘Transparent Condition’ (N = 24), the blue and green cuboids were**  
 2395 **displayed against a dark background. B) In the ‘Vertical Grating - Optic Flow Condition’ (N =**  
 2396 **17), the cuboids were presented against a red-and-black vertical grating, which was coupled to**  
 2397 **the bee’s movements (closed-loop conditions). C) In the ‘Vertical Grating - No Optic Flow**

2398 *Condition*' (N = 17), the cuboids were displayed against the same red-and-black grating but  
 2399 motion cues from the background were suppressed by keeping it constantly fixed to the bee's  
 2400 gaze. **D**) In the '*Rotating Vertical Grating Condition*' (N = 17), the cuboids were shown against  
 2401 the same red-and-black grating, which was rotated counterclockwise around the virtual arena  
 2402 at a constant speed, thus generating a constant optic flow even when the bee did not move.  
 2403 **Panels E-H** refer to the **fixation time**, i.e. the time spent fixating either the CS+ or the CS-  
 2404 during the test. Bars represent the mean fixation time. Error bars indicate the standard error of  
 2405 the mean. \*:  $p < 0.05$ ; ns: non-significant. **E**) '*Transparent Condition*' (N = 24). **F**) '*Vertical*  
 2406 *Grating - Optic Flow Condition*' (N = 17). **G**) '*Vertical Grating - No Optic Flow Condition*'  
 2407 (N = 17). **H**) '*Rotating Vertical Grating Condition*' (N = 17). The bottom row shows the heat  
 2408 map corresponding to each condition. Each heat map shows the cumulative coordinates  
 2409 occupied by the bees under each background condition during the test. Coordinates were binned  
 2410 into 1 cm<sup>2</sup>. Warmer colors depict locations more frequently occupied (see color bar). The  
 2411 highest frequency is cut down to 10 % of the maximum on the color bar. The rewarded stimulus  
 2412 was placed arbitrarily on the right.

### 2413 Experiment 3: Influence of ventral optic cues on visual discrimination learning

2414 We assessed the importance of the ventral optic flow by training two different groups of bees  
 2415 to discriminate the green from the blue cuboid in the previous '*Transparent Condition*' in which  
 2416 color learning was possible. The groups differed in the Styrofoam ball onto which the bees  
 2417 walked. For one group, the ball was homogeneously white (Fig. 1C) so that no ventral motion  
 2418 cues were available to the walking bees ('*No Ventral Optic Flow Condition*', N = 29 bees). For  
 2419 the other group, the ball presented a black-and-white checkered pattern made of 7 mm<sup>2</sup> squares  
 2420 (Fig. 1D; '*Ventral Optic Flow Condition*', N = 38 bees) so that ventral optic flow was available  
 2421 to the walking bees.

### 2422 Discrimination learning during training

2423 Learning curves were again obtained by recording the percentage of bees correctly choosing  
 2424 the CS+ or the CS- in their first choice, or not choosing any stimulus (NC) during each trial.  
 2425 Figure 7A,B shows the learning curves obtained under the two ventral optic flow conditions  
 2426 and the cumulative heat map showing equal interaction with the two cuboid sides along trials.  
 2427 Yet, in this case the model that provided the best fit to the data included a three-way interaction  
 2428 between choices, trial number and color ( $Color * Trial * Choice: \chi^2 = 64.30, df:7, p < 0.001$ ) but  
 2429 with no significant effect of the type of ball used ( $Condition: \chi^2 = 0, df:1, p = 1$ ). This shows  
 2430 that the availability of ventral optic flow did not influence the bees' performance when the  
 2431 variable quantified was the stimulus choice and that, on the contrary, a color effect existed. To  
 2432 analyze this effect, we pooled acquisition performances irrespective of the ventral optic flow  
 2433 condition, and represented them in terms of a green vs. blue discrimination (Fig. 7C: blue+ vs.  
 2434 green-; Fig. 7D: blue- vs. green+).

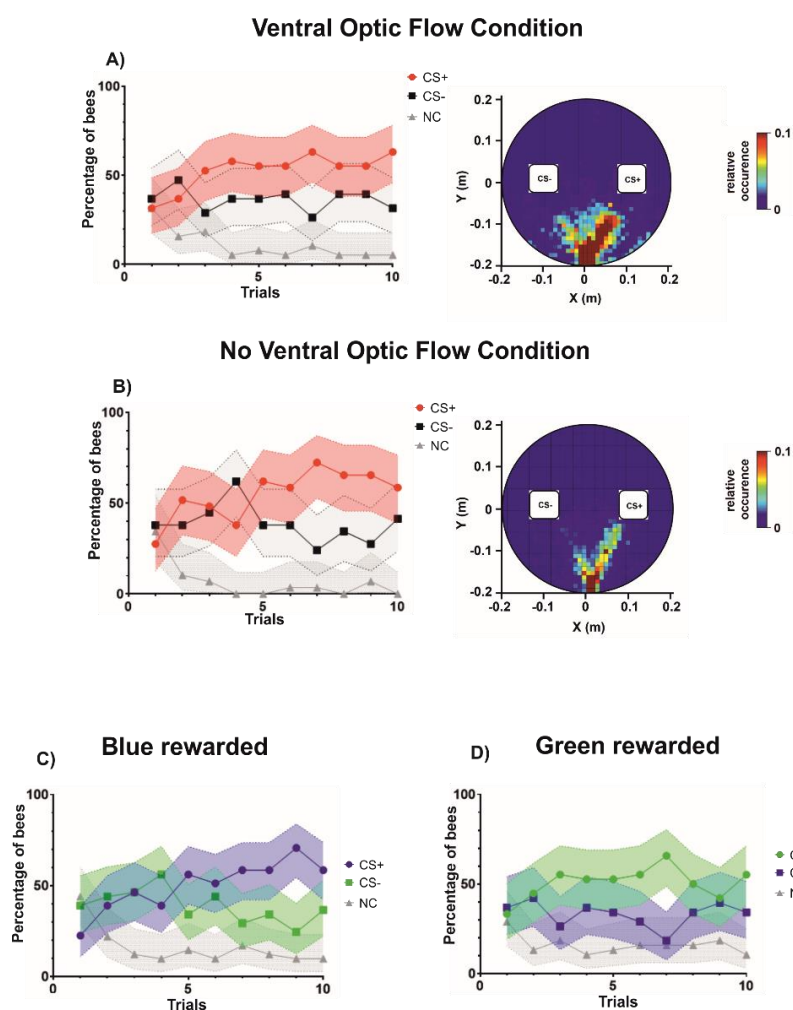

2435

2436 **Figure 7. Acquisition performances in a color discrimination learning task under two**  
 2437 **different ventral optic-flow conditions. A) Color discrimination learning with motion cues**  
 2438 **available ventrally on the treadmill (N= 38). Left:** Acquisition curves in terms of the  
 2439 percentage of bees responding to the CS+ (red), to the CS- (black) or not making any choice  
 2440 (NC; gray) during the ten conditioning trials. The pink, light gray and gray areas around the  
 2441 curves represent the 95% confidence interval of CS+, CS- choices and NC, respectively. **Right:**  
 2442 Heat map showing the cumulative coordinates occupied by the bees trained under this condition  
 2443 during the ten training trials. Coordinates were binned into 1 cm<sup>2</sup>. Warmer colors depict  
 2444 locations more frequently occupied (see color bar). The highest frequency is cut down to 10 %  
 2445 of the maximum on the color bar. While the side of the rewarded stimulus was randomized  
 2446 along conditioning trials, it was placed arbitrarily on the right in the heat maps. **B) Color**  
 2447 **discrimination learning in the absence of ventral motion cues on the treadmill (N= 29).**  
 2448 **Left:** Acquisition curves as in A). **Right:** Heat map as in A). **C) Data pooled for the two optic-**  
 2449 **flow conditions and segregated according to the situation in which the CS+ color was Blue**  
 2450 **while the CS- color was Green.** Acquisition curves in terms of the percentage of bees  
 2451 responding to the CS+ (blue), to the CS- (green) or not making any choice (NC; gray) during  
 2452 the ten conditioning trials. The blue, green and gray areas around the curves represent the 95%  
 2453 confidence interval of blue+, green- choices and NC, respectively. **D) Data pooled for the two**  
 2454 **optic-flow conditions and segregated according to the situation in which the CS+ color**  
 2455 **was green while the CS- color was blue.** Acquisition curves in terms of the percentage of bees  
 2456 responding to the CS+ (green), to the CS- (blue) or not making any choice (NC; gray) during  
 2457 the ten conditioning trials. The green, blue and gray areas around the curves represent the 95%  
 2458 confidence interval of green+, blue- choices and NC, respectively.

2459 In both color conditions, the percentages of bees choosing the stimuli varied along trials  
 2460 (*Choice\*Trial*: Blue:  $\chi^2 = 48.86$ , df:2,  $p < 0.001$ ; Green:  $\chi^2 = 15.47$ , df:2,  $p < 0.001$ ). However,  
 2461 the dynamic of the percentage of bees choosing the CS+ and that of bees choosing the CS-  
 2462 differed significantly only when blue was the rewarded color. In this case, the percentages of  
 2463 bees responding to blue (CS+) and to green (CS-) along trials differed significantly (Fig. 7C;  
 2464 *Choice\*Trial*: CS+ vs. CS-:  $z = 4.88$ ,  $p < 0.001$ ). In addition, both the percentages of bees  
 2465 responding to the rewarded blue and to the punished green differed significantly from the non-  
 2466 responding bees along trials (CS+ vs. NC:  $z = 5.93$ ,  $p < 0.001$ ; CS- vs. NC:  $z = 2.62$ ,  $p = 0.009$ ).  
 2467 Segregating these data between the blue-rewarded bees that experienced the ventral optic flow  
 2468 condition and those that did not experience ventral optic flow yielded the same result. In both  
 2469 cases, the dynamic of the percentage of bees choosing the blue+ and that of bees choosing  
 2470 green- differed significantly (*'Ventral Optic Flow'*: CS+ vs. CS-:  $z = 3.62$ ,  $p < 0.001$ ; *'No*  
 2471 *Ventral Optic Flow'*: CS+ vs. CS-:  $z = 3.31$ ,  $p < 0.001$ ). When green was the rewarded color,  
 2472 no significant differences in the percentages of bees responding to green+ and that of bees  
 2473 responding to blue – was detected along trials, even if the former tended to be higher than the  
 2474 latter (Fig. 7D; *Choice\*Trial*: CS+ vs. CS-:  $z = 0.60$ ,  $p = 0.55$ ). Both percentages were  
 2475 significantly higher than that of bees not responding to any stimulus (CS+ vs. NC:  $z = 3.58$ ,  $p$   
 2476  $< 0.001$ ; CS- vs. NC:  $z = 3.23$ ,  $p = 0.001$ ). The same pattern of responses with respect to bees  
 2477 responding to green+ and to blue- was found when analyzing separately the two optic-flow  
 2478 conditions (*'Ventral Optic Flow'*: CS+ vs. CS-:  $z = 0.23$ ,  $p = 0.82$ ; *'No Ventral Optic Flow'*:  
 2479 CS+ vs. CS-:  $z = 1.16$ ,  $p = 0.25$ ).

#### 2480 **Motor and temporal components of bee trajectories during training**

2481 We analyzed the motor performance of bees in the two conditions described above to determine  
 2482 if and how ventral motion cues affected the displacement of bees in the VR setup during the  
 2483 training trials (Fig. 8A-D). The distance walked during the acquisition phase (Fig. 8A) was  
 2484 affected by the presence of ventral optic flow (*Condition*:  $\chi^2 = 7.45$ , df:1,  $p = 0.006$ ). With the  
 2485 checkered ball, the bees walked less. The walking speed during the acquisition phase (Fig. 8B)  
 2486 was also significantly slower when ventral optic flow was available (*Condition*:  $\chi^2 = 6.03$ , df:1,  
 2487  $p = 0.01$ ) although it increased significantly over trials for both conditions (*Trial*:  $\chi^2=85.20$ ; df:  
 2488 1,  $p < 0.0001$ ). The tortuosity of the walking paths (Fig. 8C) decreased over trials (*Trial*:  
 2489  $\chi^2=7.95$ , df: 1,  $p = 0.005$ ) but was unaffected by the ventral optic flow (*Condition*:  $\chi^2 = 0.56$ ,  
 2490 df:1,  $p = 0.45$ ). Finally, the latency before making a choice (Fig. 8D) was stable over trials even  
 2491 if an apparent decrease was observed in the first trials (*Trial*:  $\chi^2=1.97$ ; df: 1,  $p = 0.16$ ), and was

2492 not influenced by the ventral optic flow (*Condition*:  $\chi^2 = 0.19$ , *df*:1, *p* = 0.66). Overall, the  
 2493 significant variation in distance walked and walking speed detected between the two conditions  
 2494 shows that bees were not insensitive to the presence of ventral motion cues. They perceived  
 2495 them and in consequence walked slower and less.

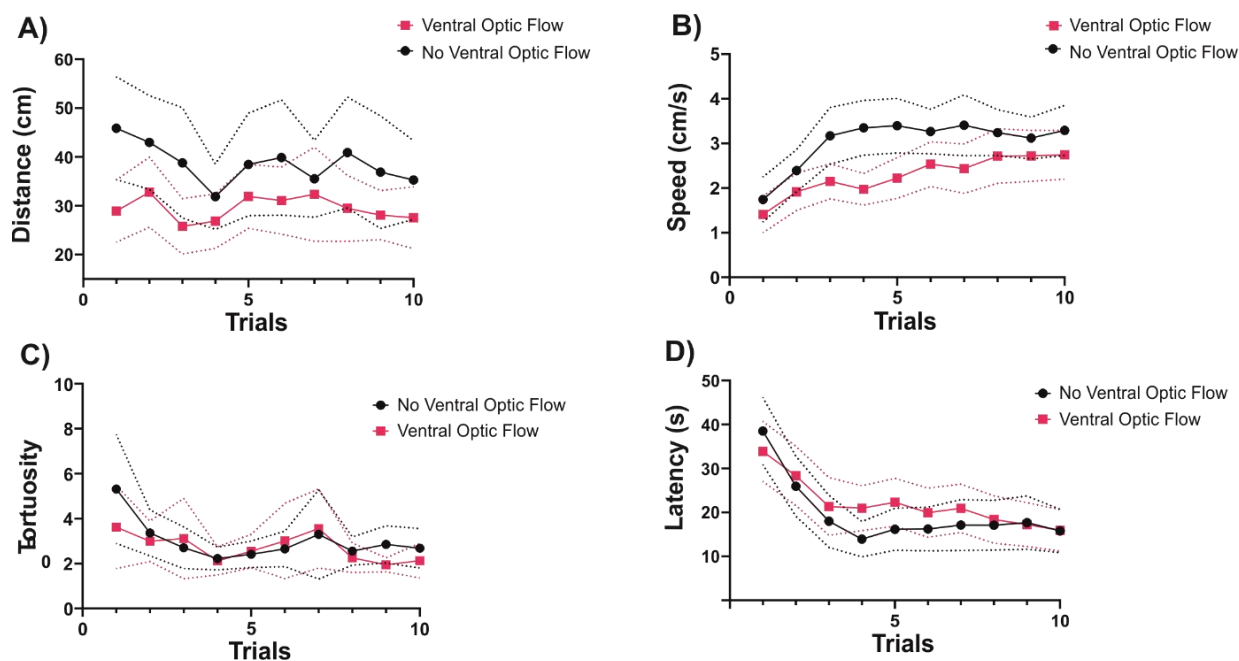

2496

2497 **Figure 8. Motor and temporal components of bee trajectories during the acquisition trials.**  
 2498 For each ventral optic-flow condition, the evolution of **A)** the distance walked, **B)** the walking  
 2499 speed, **C)** the tortuosity and **D)** the choice latency during training trials is shown. The tortuosity  
 2500 was the ratio between the total distance walked and the straight line connecting the first and the  
 2501 last point of the trajectory during a training trial. ‘*Ventral Optic Flow*’ (N = 38), ‘*No Ventral*  
 2502 *Optic Flow*’ (N = 29). The dashed lines above and below the curves represent the 95%  
 2503 confidence interval.

## 2504 Test Performance

2505 After the end of training, each bee was subjected to a test in which the green and the blue  
 2506 cuboids were presented in extinction conditions (no reinforcement provided) in the presence or  
 2507 absence of ventral optic flow. We recorded the percentage of bees correctly choosing the CS+,  
 2508 the CS- or not choosing (NC). There was no significant effect of the ventral optic flow on test  
 2509 performances when the variable considered was the choice made by the bees (*Condition*:  $\chi^2 =$   
 2510 0, *df*:1, *p* = 1). Thus, the results of both groups of bees were pooled (N = 67) and shown as a  
 2511 single graph (Fig. 9A). In this case, the color of the CS+ did not affect the performance (*Color*:  
 2512  $\chi^2 = 0$ , *df*:1, *p* = 1), thus showing that the color effect detected during training was not consistent.  
 2513 In the test, bees preferred the CS+ over all conditions (CS+ vs. CS-: *z* = 2.41, *p* = 0.02; CS+ vs.  
 2514 NC: *z* = 5.03, *p* < 0.0001; CS- vs. NC: *z* = 3.16, *p* = 0.002), thus confirming that they had  
 2515 learned the color discrimination during acquisition.

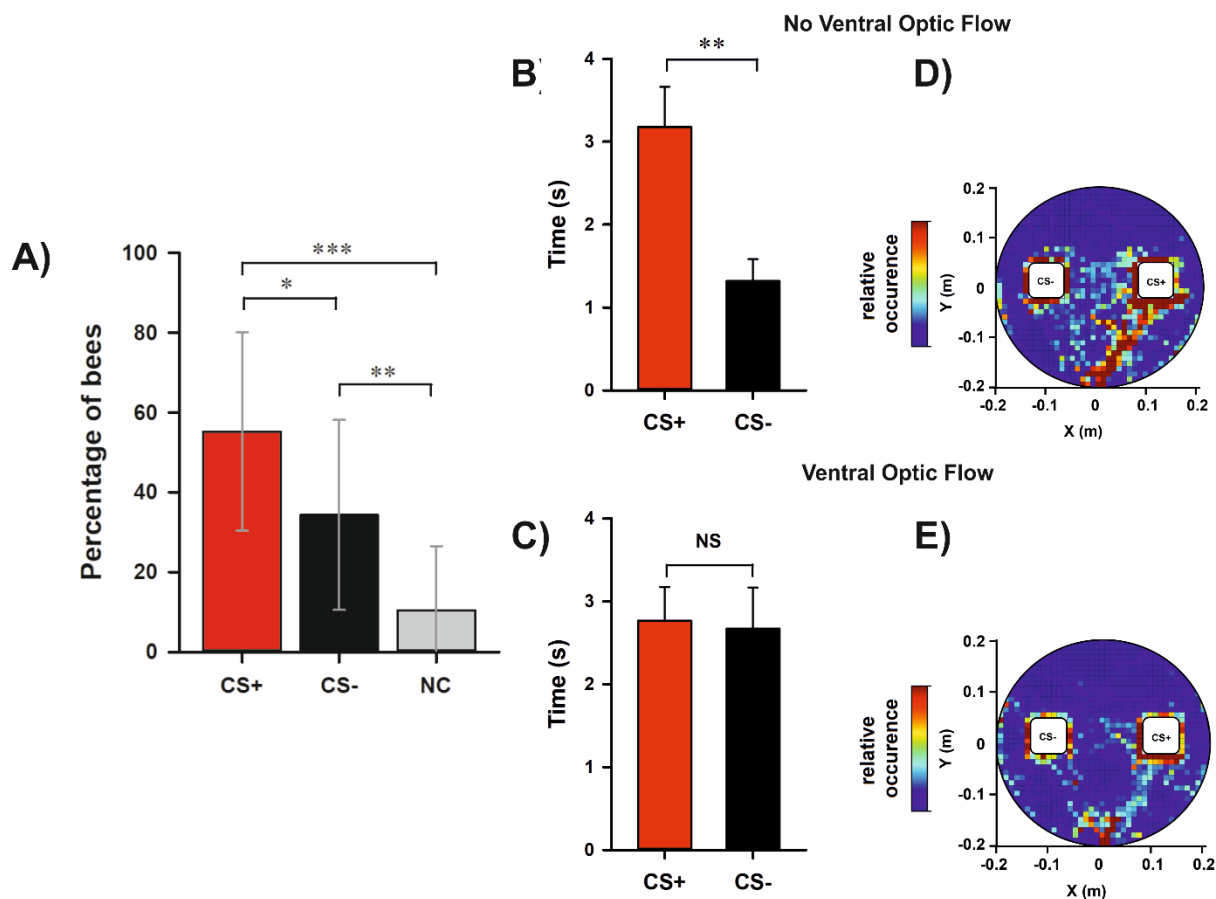

2516

2517 **Fig. 9. Test performances (1<sup>st</sup> choice and fixation time) in a color discrimination learning**  
 2518 **task under two different ventral optic-flow conditions (with ventral optic flow and without**  
 2519 **ventral optic flow). A) 1<sup>st</sup> choice performed during the test.** As there were neither significant  
 2520 differences between the two ventral optic-flow conditions nor between the color conditions  
 2521 (blue or green rewarded), results were pooled and presented as a single bar diagram (N = 67).  
 2522 The graph shows the percentage of bees responding to the CS+ (red), to the CS- (black) or not  
 2523 making any choice (NC; gray) during the retention test. Error bars indicate 95% confidence  
 2524 intervals. \*: p < 0.05; \*\*: p < 0.01; \*\*\*: p < 0.001. **B) & C) Fixation time during the test in**  
 2525 **the ‘No Ventral Optic Flow Condition’ and in the ‘Ventral Optic Flow Condition’,**  
 2526 **respectively.** In this case, fixation times were separated according to the experimental  
 2527 condition, as different response patterns were observed with and without ventral optic flow.  
 2528 The graphs show the mean time ( $\pm$  S.E.) spent fixating either the CS+ or the CS- during the  
 2529 retention test. **B)** In the ‘No Ventral Optic Flow Condition’, bees fixated significantly longer  
 2530 the CS+ than the CS-. \*\*: p < 0.01. **C)** In the ‘Ventral Optic Flow Condition’, bees fixated  
 2531 equally the CS+ and the CS-. NS: not significant. **D) & E) Heat maps showing the cumulative**  
 2532 **coordinates occupied by the bees during the test in the ‘No Ventral Optic Flow Condition’**  
 2533 **and in the ‘Ventral Optic Flow Condition’, respectively.** The CS+ is shown on the right by  
 2534 convention. Coordinates were binned into 1 cm<sup>2</sup>. Warmer colors depict locations more  
 2535 frequently occupied (see color bar). The highest frequency is cut down to 10 % of the maximum  
 2536 on the color bar. **D)** In the ‘No Ventral Optic Flow Condition’, bees clearly aimed at the CS+  
 2537 besides choosing it more frequently in their first choice. **E)** In the ‘Ventral Optic Flow  
 2538 Condition’, bees also aimed at the CS+ but in a less clear way.

2539

2540 The analysis of the fixation time showed a significant difference between the conditions  
2541 '*Ventral Optic Flow*' and '*No Ventral Optic Flow*'. Bees fixated significantly longer the CS+  
2542 than the CS- in the absence of ventral optic flow (Fig. 9B;  $V = 320$ ,  $p = 0.008$ ) while they  
2543 fixated equally both stimuli in the presence of ventral optic flow (Fig. 9C;  $V = 373$ ;  $p = 0.75$ ).  
2544 The first condition is identical to the '*Transparent Condition*' previously studied, in which a  
2545 white ball was used as a treadmill. The results were, therefore, consistent between the two  
2546 experiments: bees preferred the CS+ in their first choice and spent more time fixating it. The  
2547 second condition shows that ventral motion cues played a distractive role as only when they  
2548 were absent, did the fixation time correlate with the bees' choice.

2549 The heat maps displaying the cumulative locations occupied by the bees' trajectories  
2550 during the entire test are shown in Figs. 9D, E. In the '*No Ventral Optic Flow*' condition (Fig.  
2551 9D), bees consistently walked towards the CS+ cuboid and inspected it during the test besides  
2552 choosing it more frequently upon their first choice. In the '*Ventral Optic Flow*' condition (Fig.  
2553 9E), bees still walked towards the CS+ cuboid but in a less clear way.

## 2554 Discussion

2555 We studied the impact of motion cues provided by the background on visual-discrimination  
2556 learning by honey bees in virtual-reality conditions. Bees had to learn the difference between  
2557 two virtual color cuboids, one of which was rewarded while the other was punished. We focused  
2558 both on motion cues derived from a background placed frontally 'behind' the color stimuli, and  
2559 from a ventral ground, which was perceived in the ventral visual field while the bee walked on  
2560 a Styrofoam ball. In the latter case, the perceived optic flow had no direct relation with the  
2561 cuboids perceived in the frontal field. The color discrimination task was set under closed loop  
2562 conditions so that in the case of the grating displayed frontally, both the cuboids and the  
2563 background could vary (translation and expansion) according to the bees' movements. Our  
2564 results indicate that in VR conditions, frontal but no ventral motion cues from the background  
2565 interfered with the learning of colors. Although ventral motion cues did not affect color  
2566 learning, they were well perceived as they affected walking distance and speed and impaired  
2567 fixation time of the rewarded stimulus during the test.

2568

**2569 Optic flow and visual performances in insects**

2570 Optic flow is the pattern of apparent motion of objects, surfaces, and edges in a visual scene  
2571 caused by the relative motion between an observer and a scene<sup>40,41</sup>. It can be seen as a vector  
2572 field that gives the retinal slip speed of each contrasting object encountered in the environment  
2573 when the observer moves and/or when features in the environment move relative to the  
2574 observer<sup>42</sup>. Optic flow processing is crucial for navigation as it allows assessing the distance to  
2575 objects encountered. Objects closer to an observer move faster in the retinal field than distant  
2576 objects, so that approaching a target induces higher optic flow while moving away from it  
2577 decreases it. This information is crucial for moving insects as it allows estimating distances in  
2578 translational segments<sup>43-46</sup> and avoiding collisions with circumventing obstacles and flying  
2579 equidistantly from parallel landmarks. For instance, when flying along narrow corridors, insects  
2580 use the magnitude of visual motion experienced in each eye to control their position, height and  
2581 speed<sup>47-49</sup>.

2582 Motion cues can be extracted at the edge of objects through parallax and allow  
2583 evaluating the distance of targets with respect to their background based on differences in their  
2584 relative retinal speed<sup>50-54</sup>. Edges are therefore contrasting regions in terms of motion-parallax  
2585 cues and are privileged by flying insects in their detection and landing strategies<sup>51</sup>. Numerous  
2586 experiments have documented this fact in honey bees<sup>50-54</sup>. An interesting example is provided  
2587 by experiments in which bees were trained to solve a discrimination between a plain black disk  
2588 and a black ring positioned a few centimeters in front of a white background. The targets  
2589 provided a good contrast to the background both in terms of intensity as well as in terms of the  
2590 motion cues provided at their edges so that bees had no problems in learning this shape  
2591 discrimination<sup>55</sup>. However, when bees were trained on the same shapes, yet cut from a textured  
2592 paper and placed in front of a similarly textured background, the task was impossible for them<sup>55</sup>.  
2593 This result shows that motion cues alone, which existed because the textured targets were  
2594 placed in front of the textured background, are not always helpful to appreciate shape  
2595 differences between targets. Interestingly, this impossible discrimination became possible after  
2596 the bees were primed by pre-training them with the easy discrimination involving plain stimuli  
2597 against the white background. This improvement shows that attentional mechanisms boosted  
2598 by the priming procedure are crucial for achieving target/background segmentation. The role of  
2599 attentional mechanisms will be discussed below.

2600

2601 **Ventral motion cues did not influence the color discrimination performance of bees in VR**  
2602 **but affected walking parameters and fixation time**

2603 Multiple layers of neurons within visual circuits in the bee brain are devoted to the segregated  
2604 processing of motion cues, which are essential to estimate distances traveled in translational  
2605 pathways<sup>56</sup>. Ventral optic flow is particularly important for insects flying in open spaces. In  
2606 consequence, flying above surfaces providing strong optic flow cues is preferred by bumblebees  
2607 over flying above featureless backgrounds<sup>57</sup>. Experiments on bumblebees trained to fly along  
2608 textured tunnels showed that in tunnels of 60 and 120 cm width, control of the lateral position  
2609 was achieved by balancing the magnitude of translational optic flow experienced in the lateral  
2610 visual field of each eye; yet, in wider tunnels, bumblebees used translational optic flow  
2611 perceived in the ventral visual field to control their lateral position and to steer along straight  
2612 tracks<sup>57</sup>. Ventral optic flow can be used to keep a constant height above the ground using a  
2613 feedback control loop in which a set point value of perceived ventral optic flow is maintained  
2614 constant by varying the lift, a solution that was shown experimentally in flying bees<sup>58,59</sup> and  
2615 that proved to be efficient when implemented in flying robots that needed to keep a constant fly  
2616 height<sup>60</sup>.

2617 These and other findings<sup>59,61-63</sup> clearly show the importance of ventral motion cues for  
2618 the translational displacements of flying insects. Although less information is available for  
2619 walking insects, experiments performed on desert ants *Cataglyphis fortis* walking in narrow  
2620 tunnels showed that both the lateral and the ventral optic flow were dispensable for distance  
2621 estimation<sup>64</sup>. In these insects, the use of a ‘pedometer’ was proposed, i.e. a stride integrator that  
2622 accounts for stride number and the respective stride length<sup>65,66</sup>. Although optic flow can be  
2623 computed by these ants, as shown by the case of ants transported by nestmates, which rely on  
2624 the optic flow perceived during their transport<sup>67</sup>, the primary mechanism to gauge distances is  
2625 based on idiothetic cues.

2626 In our experiments, bees walking on a Styrofoam ball were partially affected by the  
2627 presence or absence of ventral optic-flow cues (Figs. 7-9). During the training, these cues did  
2628 not affect the learning performance measured in terms of color choice (Fig. 7). Yet, we found  
2629 an effect of color, suggesting that discrimination learning was better when blue was the  
2630 rewarded color. However, this effect disappeared during the test (Fig. 9), as the first choice of  
2631 the bees revealed that they preferred significantly the CS+, irrespective of its color. Ventral  
2632 motion cues affected the other variable recorded during the test, the time spent fixating the  
2633 cuboids (Figs. 9 B,C). When these cues were absent, bees fixated more the CS+, consistently

2634 with their first color choice; however, when ventral motion cues were available, they fixated  
2635 both the CS+ and the CS- to similar extents, even if they preferred the CS+ in their first color  
2636 choice. Thus, ventral motion cues interfered with the time spent fixating the CS+ during the  
2637 test.

2638           The absence of effect of ventral motion cues during the training did not mean that bees  
2639 did not pay attention to them or that they were unable to perceive the difference between the  
2640 two walking surfaces. Fig. 8A,B shows that both the distance walked and the walking speed  
2641 decreased significantly when ventral motion cues were available, thus showing that bees  
2642 perceived them. Their impact on these motor variables indicates, in addition, that such cues are  
2643 relevant for estimating walking distances. This conclusion goes against the possibility that in a  
2644 walking context, bees, like desert ants, rely on a mechanism for estimating distances different  
2645 from that employed during flight. In fact, it is difficult to conceive how the relevance of optic  
2646 flow could be switched off during walking, given its fundamental role for bee navigation.

2647           Alternatively, our findings may indicate that ventral optic-flow cues play a fundamental  
2648 role *en route* to the goal for distance estimation and completion of an intended translational  
2649 vector, but not in the immediate vicinity of the goal, when the insect faces the task of close-up  
2650 object recognition. In the latter situation, translational ventral optic flow may be irrelevant as  
2651 the goal has been reached. Last but not least, it is worth considering that our experiments did  
2652 not create a ventral optic flow in the virtual arena, i.e. below the targets to be discriminated, but  
2653 only on the walking treadmill. Including ventral motion cues in the floor of the virtual arena  
2654 could affect the choice of the color cuboids in a way similar to that induced by the frontal  
2655 motion cues from the background.

2656

### 2657 **Frontal motion cues from the background interfered with the color discrimination** 2658 **performance of bees in VR**

2659 Motion cues perceived frontally at the edges of vertically displayed targets allows segregating  
2660 them from their respective background based on motion parallax cues. This feature extraction  
2661 improves therefore object identification and landing on targets. Yet, in our experiments,  
2662 whenever motion cues from the background were available (*‘Vertical Grating - Optic Flow*  
2663 *Condition’* and *‘Rotating Vertical Grating Condition’*; see Fig. 4), color discrimination of  
2664 objects located in the virtual foreground was impaired. This result is in contradiction with the  
2665 hypothesis that animals should behave better in more realistic environments and challenges *a*

2666 *priori* efforts towards enriching our VR environment with additional cues besides those to be  
2667 learned and discriminated. Indeed, learning was only possible in the total absence of a frontal  
2668 background (*'Transparent Condition'*, Fig. 4), suggesting that background cues interfered with  
2669 the learning of foreground objects. Interestingly, in the *'Vertical Grating - No Optic Flow*  
2670 *Condition'*, optic flow from the background was artificially suppressed and yet learning was  
2671 not apparent even if a tendency towards a segregation of CS+ and CS- curves was observed  
2672 (see Fig. 4B). However, when test performances were analyzed in terms of the time spent  
2673 fixating the CS+ and the CS-, a significant difference in favor of the former was found, which  
2674 is consistent with a learning effect. The fact that performances were not as clear as in the  
2675 *'Transparent Condition'* suggests that the mere presence of the background may have been  
2676 distractive for the bees. Thus, both the motion cues emanating from the background, and its  
2677 illumination conditions, may have interfered with color learning in the VR arena.

2678         A first explanation for this interference could rely on the role of irradiance cues used to  
2679 establish the background in our VR environment. The background was projected onto the  
2680 semicircular screen of our setup by a videoprojector and therefore provided irradiance cues that  
2681 could have attracted the bees based on positive phototaxis, thus interfering with color  
2682 discrimination. As bees are tested in the dark, a situation inherent to the use of a videoprojector,  
2683 phototaxis may have indeed influenced the behavior of the bees in our VR setup as shown in  
2684 experiments performed in open-loop conditions using the same kind of videoprojector-based  
2685 display<sup>12</sup>. Admittedly, the green and the blue lights used for training the bees had 22 times and  
2686 143 times more irradiance than the red used for the background (Red 100: RGB: 255, 0, 0;  
2687 irradiance: 1130  $\mu\text{W}/\text{cm}^2$ ). It could be interesting to determine if a similar interference with  
2688 color learning would take place when using the other red light that the bees could see (Red 50:  
2689 RGB: 128, 0, 0; irradiance: 140  $\mu\text{W}/\text{cm}^2$ ; see Fig. 3). For this light, the difference of irradiance  
2690 between colors and background decreases in one order of magnitude with respect to the Red  
2691 100 used in our experiments. In theory, using the Red 50 light should not change the main  
2692 findings reported because the phototactic attraction exerted by this stimulus was identical to  
2693 that induced by the Red 100 light (see Figs. 3 B and C).

2694         Another reason for the negative influence of motion cues emanating from the frontal  
2695 background could be an excessive salience of these cues with respect to those from the  
2696 foreground objects that had to be discriminated. In natural conditions, background objects  
2697 provide motion cues that are less salient than those of foreground objects. Although we  
2698 attempted to reproduce this situation in our VR environment (the expansion of the cuboids

2699 during forward motion was  $1.7^\circ/\text{cm}$  while that of a red bar from the background was  $0.18$   
2700  $^\circ/\text{cm}$ ), the optic flow generated by the background might still have been too high and detracted  
2701 bees from efficiently learning the discrimination task.

2702 Finally, in the '*Rotating Vertical Grating Condition*', optomotor responses triggered by  
2703 the background rotating regularly in front of the bees may have interfered with the color  
2704 learning task. To determine if this was the case, we analyzed the cumulative turning exhibited  
2705 by the bees in this condition and in the '*Transparent Condition*', where no background was  
2706 available. Figure S2 shows that the cumulative turning in the direction of the rotating  
2707 background (to the left) was significantly higher in the '*Rotating Vertical Grating Condition*',  
2708 which indicates the presence of optomotor responses. These responses may have interfered with  
2709 color learning and may be one of the causes of the impaired performance observed.

2710

### 2711 **Chromatic and achromatic vision in the VR setup**

2712 Bees were trained to discriminate two different colors against an achromatic background. Blue  
2713 and green colors differing in intensity were used to this end (Fig. S1A), which may have resulted  
2714 in bees using differences in intensity rather than chromatic differences to solve the task when  
2715 motion cues from the background did not interfere (i.e. in the '*Transparent Condition*'; see Fig.  
2716 4A). Yet, this possibility is ruled out by the performance of the bees itself. In this condition, no  
2717 asymmetries in color learning were observed depending on which color was rewarded. Had the  
2718 bees been guided by achromatic intensity, then significant learning asymmetries should have  
2719 emerged: bees trained to the less intense green should show impaired learning, detracted by the  
2720 highly intense blue displayed by the alternative non-rewarded stimulus. On the contrary bees  
2721 trained to the highly intense blue should have their performances amplified by the attraction  
2722 induced by the blue light. This was not the case and no color effect was observed in this  
2723 experiment. The situation presented in the '*Transparent Condition*' was reproduced in the  
2724 experiments studying the effect of the ventral optic flow, when the surface of the treadmill was  
2725 plain white (see Fig. 7, '*No Optic Flow Condition*'). In this case, a color effect consistent with  
2726 the use of intensity was visible during the training, as performance was better when blue was  
2727 rewarded than when green was rewarded (see Fig. 7C,D). However, this effect disappeared  
2728 during the test (see Fig. 9), showing that it was inconsistent and that even the bees rewarded on  
2729 the green color learned the task. These results indicate that in the absence of distractive motion  
2730 cues from the background, the bees were mainly guided by chromatic cues from the blue and  
2731 green colors although we cannot definitely rule out an incidence of stimulus intensity in these

2732 experiments. Note that the same colors were used in previous studies performed in our VR setup  
2733 and that no color asymmetry was found, which goes against the use of color intensity by the  
2734 bees<sup>12-16,27</sup>.

2735 An additional issue that requires consideration is the possible interference of the red  
2736 light (Red 100) used for the background with the color vision system of the bees involved in  
2737 the blue-green discrimination. Fig. S1 shows that Red 100 could only be perceived *via* the L  
2738 (Green) receptor type, i.e. *via* an achromatic visual mechanism involving a single receptor type.  
2739 Bees can see red (see Fig. 3), not as a color, but as an achromatic stimulus, perceived in terms  
2740 of its intensity by the L receptor<sup>32,33</sup>. Whether Red 100 affected negatively chromatic  
2741 discrimination, interfering with the L-receptor type involved in this discrimination is unknown.  
2742 VR experiments with freely flying bumblebees trained to land on a virtual horizontal blue target  
2743 located on a projected achromatic checkerboard made of random pink (RGB: 255, 127, 127)  
2744 and white (RGB: 255, 255, 255) squares showed that the background had no incidence on the  
2745 bees' performance<sup>61</sup>. In this case, the pink light used could potentially stimulate all receptor  
2746 types and thus truly affect the color vision system, contrarily to our red light (RGB: 255, 0, 0).  
2747 The fact that this was not the case suggests a minor effect, if any, of the red light in our color  
2748 discrimination experiments.

2749

## 2750 **Conclusion**

2751 Our results point towards deficits in attentional processes underlying color discrimination  
2752 whenever motion cues from the background were frontally available in our VR setup. In the  
2753 case of ventral motion cues, no interference of color learning was observed, yet, a distractive  
2754 effect on the time spent fixating the stimuli was detected during the test. Attention plays a  
2755 fundamental role in visual discrimination tasks achieved by bees and other insects<sup>68-71</sup>.  
2756 Attention is defined as the "*ability to focus our perception on one stimulus (or group of related*  
2757 *stimuli), while filtering out other simultaneous stimuli that are less relevant at any moment*"<sup>72</sup>.  
2758 Several studies focusing on color discrimination by bees have underlined the importance of  
2759 attention in this context. In particular, differential conditioning protocols –as the one used in  
2760 this work – are said to require more attention than absolute conditioning, the simple training of  
2761 a single stimulus<sup>73</sup>, in particular when the stimuli to be discriminated are similar<sup>34</sup>. The role of  
2762 attention in visual object recognition was studied by training bees to choose a colored target  
2763 disc among a variable number of differently colored distractor discs<sup>74</sup>. Accuracy and decision

2764 time were measured as a function of distractor number and color. For all color combinations,  
2765 decision time increased and accuracy decreased with increasing distractor number, whereas  
2766 performance improved when more targets were present.

2767         From this perspective, highly salient irradiance or motion cues from the background  
2768 may have interfered with attentional processes required to achieve the color cuboid  
2769 discrimination. Further experiments may explore strategies to reduce their salience and thus  
2770 enable their perceptual filtering in our VR landscape.

2771

## 2772 **Acknowledgements**

2773 We thank two anonymous reviewers for useful comments and suggestions on previous versions  
2774 of this article. This work was supported by an ERC Advanced Grant ('Cognibrains') to M.G,  
2775 who also thanks the Institut Universitaire de France (IUF), the CNRS and the University Paul  
2776 Sabatier/Fondation Catalyses for support. S.R.H. was supported by a post-doctoral fellowship  
2777 of the Fyssen Foundation.

2778

## 2779 **Contributions**

2780 M.G, A.A.-W and G.L. designed the experiment. G.L built the setup and wrote the VR software.  
2781 G.L performed all the behavioral experiments. S.R.H. contributed to the behavioral  
2782 experiments. Rodrigue Fouillet, Juliette Montet, Diane Sam Mine and Emma Giordanengo also  
2783 assisted with the behavioral experiments. Behavioral experiments were supervised by M.G.  
2784 and A.A.-W. Heat maps and analyses of displacements within the VR were performed by G.L.  
2785 and B.P. Statistical analyses were performed by A.A.-W, G.L. and MG. The manuscript was  
2786 written by M.G. who also obtained funding. All authors reviewed and approved the final version  
2787 of the manuscript.

2788

## 2789 **Ethics Declarations**

### 2790 **Competing interests**

2791 The authors declare no competing interests.

2792

2793 **References**

- 2794 1 Dombbeck, D. A. & Reiser, M. B. Real neuroscience in virtual worlds. *Curr Opin Neurobiol* **22**, 3-  
2795 10 (2012).
- 2796 2 Tarr, M. J. & Warren, W. H. Virtual reality in behavioral neuroscience and beyond. *Nat*  
2797 *Neurosci* **5 Suppl**, 1089-1092 (2002).
- 2798 3 Götz, K. G. Optomotorische Untersuchung des visuellen systems einiger Augenmutanten der  
2799 Fruchtfliege *Drosophila*. *Kybernetik* **2**, 77-92 (1964).
- 2800 4 Wolf, R. & Heisenberg, M. Visual orientation in motion-blind flies is an operant behaviour.  
2801 *Nature* **323**, 154-156 (1986).
- 2802 5 Wolf, R., Voss, A., Hein, S. & Heisenberg, M. Can a fly ride a bicycle? *Phil Trans R Soc Lond B*  
2803 **337**, 261-269 (1992).
- 2804 6 Brembs, B. & Heisenberg, M. The operant and the classical in conditioned orientation of  
2805 *Drosophila melanogaster* at the flight simulator. *Learn Mem* **7**, 104-115 (2000).
- 2806 7 Brembs, B. & Heisenberg, M. Conditioning with compound stimuli in *Drosophila*  
2807 *melanogaster* in the flight simulator. *J Exp Biol* **204**, 2849-2859 (2001).
- 2808 8 Kramer, E. in *Olfaction and Taste* Vol. V (eds D. Denton & J.D. Coghlan) 329-335 (Academic  
2809 Press, 1975).
- 2810 9 Kramer, E. The orientation of walking honeybees in odour fields with small concentration  
2811 gradients. *Physiol Entomol* **1**, 27-37 (1976).
- 2812 10 Dahmen, H., Wahl, V. L., Pfeffer, S. E., Mallot, H. A. & Wittlinger, M. Naturalistic path  
2813 integration of *Cataglyphis* desert ants on an air-cushioned lightweight spherical treadmill. *J*  
2814 *Exp Biol* **220**, 634-644 (2017).
- 2815 11 Goulard, R., Buehlmann, C., Niven, J. E., Graham, P. & Webb, B. A motion compensation  
2816 treadmill for untethered wood ants *Formica rufa*: evidence for transfer of orientation  
2817 memories from free-walking training. *J Exp Biol* **223**, jeb228601 (2020).
- 2818 12 Buatois, A. *et al.* Associative visual learning by tethered bees in a controlled visual  
2819 environment. *Sci Rep* **7**, 12903 (2017).
- 2820 13 Buatois, A., Flumian, C., Schultheiss, P., Avargues-Weber, A. & Giurfa, M. Transfer of visual  
2821 learning between a virtual and a real environment in honey bees: the role of active vision.  
2822 *Front Behav Neurosci* **12**, 139 (2018).
- 2823 14 Rusch, C., Roth, E., Vinauger, C. & Riffell, J. A. Honeybees in a virtual reality environment  
2824 learn unique combinations of colour and shape. *J Exp Biol* **220**, 3478-3487 (2017).
- 2825 15 Buatois, A., Laroche, L., Lafon, G., Avargues-Weber, A. & Giurfa, M. Higher-order  
2826 discrimination learning by honeybees in a virtual environment. *Eur J Neurosci* **51**, 681-694  
2827 (2020).
- 2828 16 Zwaka, H. *et al.* Learning and its neural correlates in a virtual environment for honeybees.  
2829 *Front Behav Neurosci* **12**, 279 (2018).
- 2830 17 Seelig, J. D. *et al.* Two-photon calcium imaging from head-fixed *Drosophila* during optomotor  
2831 walking behavior. *Nat Meth* **8**, 184-184 (2011).
- 2832 18 Seelig, J. D. & Jayaraman, V. Neural dynamics for landmark orientation and angular path  
2833 integration. *Nature* **521**, 186-191 (2015).
- 2834 19 Paulk, A. C. *et al.* Selective attention in the honeybee optic lobes precedes behavioral  
2835 choices. *Proc Natl Acad Sci U S A* **111**, 5006-5011 (2014).
- 2836 20 Peckmezian, T. & Taylor, P. W. A virtual reality paradigm for the study of visually mediated  
2837 behaviour and cognition in spiders. *Anim Behav* **107**, 87-95 (2015).
- 2838 21 Avargues-Weber, A., Mota, T. & Giurfa, M. New vistas on honey bee vision. *Apidologie* **43**,  
2839 244-268 (2012).
- 2840 22 Avargues-Weber, A., Deisig, N. & Giurfa, M. Visual cognition in social insects. *Annu Rev*  
2841 *Entomol* **56**, 423-443 (2011).
- 2842 23 Giurfa, M. & Menzel, R. Insect visual perception: complex abilities of simple nervous systems.  
2843 *Curr Opin Neurobiol* **7**, 505-513 (1997).

- 2844 24 Avarguès-Weber, A. & Mota, T. Advances and limitations of visual conditioning protocols in  
2845 harnessed bees. *J Physiol Paris* **110**, 107-118 (2016).
- 2846 25 Mota, T., Yamagata, N., Giurfa, M., Gronenberg, W. & Sandoz, J. C. Neural organization and  
2847 visual processing in the anterior optic tubercle of the honeybee brain. *J Neurosci* **31**, 11443-  
2848 11456 (2011).
- 2849 26 Mota, T., Gronenberg, W., Giurfa, M. & Sandoz, J. C. Chromatic processing in the anterior  
2850 optic tubercle of the honeybee brain. *J Neurosci* **33**, 4-16 (2013).
- 2851 27 Rusch, C., Alonso San Alberto, D. & Riffell, J. A. Visuo-motor feedback modulates neural  
2852 activities in the medulla of the honeybee, *Apis mellifera*. *J Neurosci* **41**, 3192-3203 (2021).
- 2853 28 Schultheiss, P., Buatois, A., Avargues-Weber, A. & Giurfa, M. Using virtual reality to study  
2854 visual performances of honeybees. *Curr Opin Insect Sci* **24**, 43-50 (2017).
- 2855 29 Jin, N., Paffhausen, B. H., Duer, A. & Menzel, R. Mushroom body extrinsic neurons in walking  
2856 bumblebees correlate with behavioral states but not with spatial parameters during  
2857 exploratory behavior. *Front Behav Neurosci* **14**, 590999 (2020).
- 2858 30 Paffhausen, B. H. *et al.* Neural correlates of social behavior in mushroom body extrinsic  
2859 neurons of the honeybee *Apis mellifera*. *Front Behav Neurosci* **14**, 62 (2020).
- 2860 31 Duer, A., Paffhausen, B. H. & Menzel, R. High order neural correlates of social behavior in the  
2861 honeybee brain. *J Neurosci Methods* **254**, 1-9 (2015).
- 2862 32 Reisenman, C. E. & Giurfa, M. Chromatic and achromatic stimulus discrimination of long  
2863 wavelength (red) visual stimuli by the honeybee *Apis mellifera*. *Arthropod Plant Interact* **2**,  
2864 137-146 (2008).
- 2865 33 Chittka, L. & Waser, N. M. Why red flowers are not invisible to bees. *Isr J Plant Sci* **45**, 169-  
2866 183 (1997).
- 2867 34 Avarguès-Weber, A., de Brito Sanchez, M. G., Giurfa, M. & Dyer, A. G. Aversive reinforcement  
2868 improves visual discrimination learning in free-flying honeybees. *PLoS One* **5**, e15370 (2010).
- 2869 35 de Brito Sanchez, M. G., Serre, M., Avargues-Weber, A., Dyer, A. G. & Giurfa, M. Learning  
2870 context modulates aversive taste strength in honey bees. *J Exp Biol* **218**, 949-959 (2015).
- 2871 36 Aguiar, J., Roselino, A. C., Sazima, M. & Giurfa, M. Can honey bees discriminate between  
2872 floral-fragrance isomers? *J Exp Biol* **221** (2018).
- 2873 37 Bestea, L. *et al.* Peripheral taste detection in honey bees: what do taste receptors respond  
2874 to? *Eur J Neurosci* (2021).
- 2875 38 R Development Core Team. *R: A Language and Environment for Statistical Computing*. (The R  
2876 Foundation for Statistical Computing, 2016).
- 2877 39 Bates, D., Mächler, M., Bolker, B. & Walker, S. Fitting linear mixed-effects models using lme4.  
2878 *J Stat Softw* **67**, 1-48 (2015).
- 2879 40 Gibson, J. J. Visually controlled locomotion and visual orientation in animals. *Br J Psychol* **49**,  
2880 182-194 (1958).
- 2881 41 Lee, D. N. The optic flow field: the foundation of vision. *Philos Trans R Soc Lond B Biol Sci* **290**,  
2882 169-179 (1980).
- 2883 42 Koenderink, J. J. Optic flow. *Vision Res* **26**, 161-179 (1986).
- 2884 43 Esch, H. E. & Burns, J. E. Honeybees use optic flow to measure the distance of a food source.  
2885 *Naturwissenschaften* **82**, 38-40 (1995).
- 2886 44 Esch, H. E. & Burns, J. E. Distance estimation by foraging honeybees. *J Exp Biol* **199**, 155-162  
2887 (1996).
- 2888 45 Esch, H. E., Zhang, S., Srinivasan, M. V. & Tautz, J. Honeybee dances communicate distances  
2889 measured by optic flow. *Nature* **411**, 581-583 (2001).
- 2890 46 Tautz, J. *et al.* Honeybee odometry: performance in varying natural terrain. *PLoS Biol* **2**, E211  
2891 (2004).
- 2892 47 Srinivasan, M. V., Zhang, S., Altwein, M. & Tautz, J. Honeybee navigation: nature and  
2893 calibration of the "odometer". *Science* **287**, 851-853 (2000).
- 2894 48 Lecoœur, J., Dacke, M., Floreano, D. & Baird, E. The role of optic flow pooling in insect flight  
2895 control in cluttered environments. *Sci Rep* **9**, 7707 (2019).

- 2896 49 Si, A., Srinivasan, M. V. & Zhang, S. Honeybee navigation: properties of the visually driven  
2897 'odometer'. *J Exp Biol* **206**, 1265-1273 (2003).
- 2898 50 Lehrer, M., Srinivasan, M. V., Zhang, S. W. & Horridge, G. A. Motion cues provide the bee's  
2899 visual world with a third dimension. *Nature* **332**, 356-357 (1988).
- 2900 51 Lehrer, M. & Srinivasan, M. V. Object detection by honeybees: Why do they land on edges? *J*  
2901 *Comp Physiol A* **173**, 23-32 (1993).
- 2902 52 Srinivasan, M. V., Lehrer, M., Kirchner, W. H. & Zhang, S. W. Range perception through  
2903 apparent image speed in freely flying honeybees. *Vis Neurosci* **6**, 519-535 (1991).
- 2904 53 Lehrer, M., Srinivasan, M. V. & Zhang, S. W. Visual edge-detection in the honeybee and its  
2905 chromatic properties. *Proc R Soc Lond B Biol Sci* **238**, 321-330 (1990).
- 2906 54 Srinivasan, M. V., Lehrer, M. & Horridge, G. A. Visual figure ground discrimination in the  
2907 honeybee - the role of motion parallax at boundaries. *Proc R Soc Lond B Biol Sci* **238**, 331-350  
2908 (1990).
- 2909 55 Zhang, S. W. & Srinivasan, M. V. Prior experience enhances pattern discrimination in insect  
2910 vision. *Nature* **368**, 330-332 (1994).
- 2911 56 Paulk, A. C., Phillips-Portillo, J., Dacks, A. M., Fellous, J. M. & Gronenberg, W. The processing  
2912 of color, motion, and stimulus timing are anatomically segregated in the bumblebee brain. *J*  
2913 *Neurosci* **28**, 6319-6332 (2008).
- 2914 57 Linander, N., Baird, E. & Dacke, M. How bumblebees use lateral and ventral optic flow cues  
2915 for position control in environments of different proximity. *J Comp Physiol A* **203**, 343-351  
2916 (2017).
- 2917 58 Portelli, G., Ruffier, F. & Franceschini, N. Honeybees change their height to restore their optic  
2918 flow. *J Comp Physiol A* **196**, 307-313 (2010).
- 2919 59 Portelli, G., Serres, J. R. & Ruffier, F. Altitude control in honeybees: joint vision-based learning  
2920 and guidance. *Sci Rep* **7**, 9231 (2017).
- 2921 60 Franceschini, N., Ruffier, F. & Serres, J. A Bio-Inspired Flying Robot Sheds Light on Insect  
2922 Piloting Abilities. *Curr Biol* **17**, 329-335 (2007).
- 2923 61 Frasnelli, E., Hempel de Ibarra, N. & Stewart, F. J. The dominant role of visual motion cues in  
2924 bumblebee flight control revealed through virtual reality. *Front Physiol* **9**, 1038 (2018).
- 2925 62 Portelli, G., Ruffier, F., Roubieu, F. L. & Franceschini, N. Honeybees' speed depends on dorsal  
2926 as well as lateral, ventral and frontal optic flows. *PLoS One* **6**, e19486 (2011).
- 2927 63 Giurfa, M., Zaccardi, G. & Vorobyev, M. V. How do bees detect coloured targets using  
2928 different regions of their compound eyes. *J Comp Physiol A* **185**, 591-600 (1999).
- 2929 64 Ronacher, B., Gallizzi, K., Wohlgemuth, S. & Wehner, R. Lateral optic flow does not influence  
2930 distance estimation in the desert ant *Cataglyphis fortis*. *J Exp Biol* **203**, 1113-1121 (2000).
- 2931 65 Wittlinger, M., Wehner, R. & Wolf, H. The ant odometer: Stepping on stilts and stumps.  
2932 *Science* **312**, 1965-1967 (2006).
- 2933 66 Wittlinger, M., Wehner, R. & Wolf, H. The desert ant odometer: a stride integrator that  
2934 accounts for stride length and walking speed. *J Exp Biol* **210**, 198-207 (2007).
- 2935 67 Pfeffer, S. E. & Wittlinger, M. Optic flow odometry operates independently of stride  
2936 integration in carried ants. *Science* **353**, 1155-1157 (2016).
- 2937 68 Avarguès-Weber, A. & Giurfa, M. Cognitive components of color vision in honey bees: how  
2938 conditioning variables modulate color learning and discrimination. *J Comp Physiol A* **200**, 449-  
2939 461 (2014).
- 2940 69 Heisenberg, M., Wolf, R. & Brembs, B. Flexibility in a single behavioral variable of *Drosophila*.  
2941 *Learn Mem* **8**, 1-10 (2001).
- 2942 70 Sareen, P., Wolf, R. & Heisenberg, M. Attracting the attention of a fly. *Proc. Natl. Acad. Sci.*  
2943 *U.S.A.* **108**, 7230-7235 (2011).
- 2944 71 van Swinderen, B. Attention in *Drosophila*. *Int Rev Neurobiol* **99**, 51-85 (2011).
- 2945 72 Miller, S. M., Ngo, T. T. & van Swinderen, B. Attentional switching in humans and flies: rivalry  
2946 in large and miniature brains. *Front Hum Neurosci* **5**, 188 (2012).

- 2947 73 Giurfa, M. Conditioning procedure and color discrimination in the honeybee *Apis mellifera*.  
2948 *Naturwissenschaften* **91**, 228-231 (2004).
- 2949 74 Spaethe, J., Tautz, J. & Chittka, L. Do honeybees detect colour targets using serial or parallel  
2950 visual search? *J Exp Biol* **209**, 987-993 (2006).
- 2951

## Chapter 2

2952

2953 **Visual learning in a virtual reality environment upregulates immediate early**  
2954 **gene expression in the mushroom bodies of honey bees**

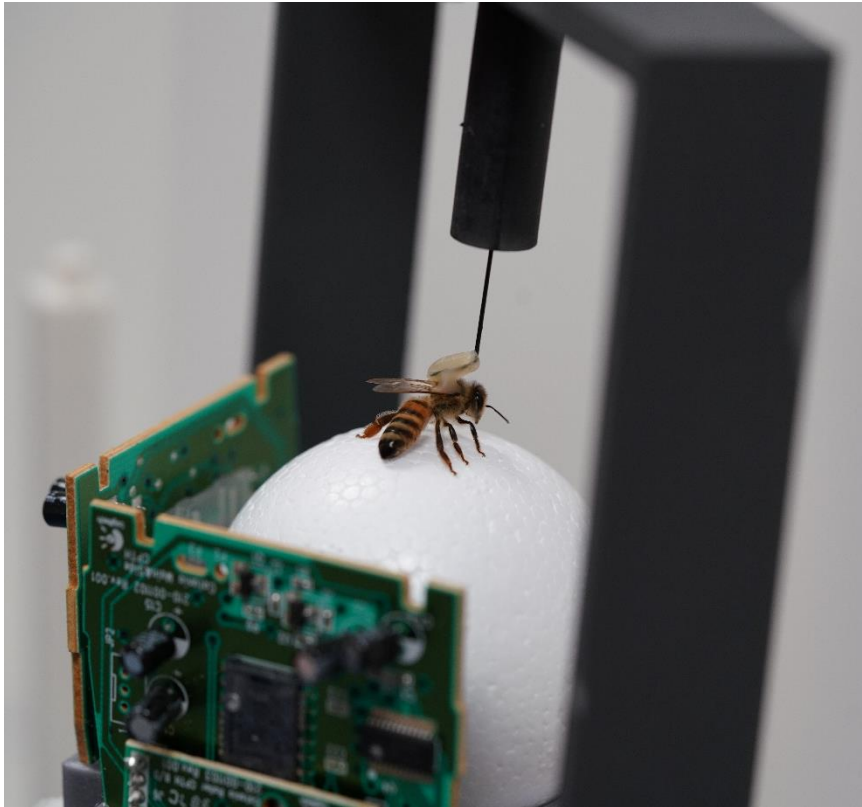

2955

2956

# communications biology

ARTICLE

<https://doi.org/10.1038/s42003-022-03075-8>

OPEN

## Visual learning in a virtual reality environment upregulates immediate early gene expression in the mushroom bodies of honey bees

Haiyang Geng<sup>1,2,5</sup>, Gregory Lafon<sup>1,5</sup>, Aurore Avarguès-Weber<sup>1</sup>, Alexis Buatois<sup>1,4,6</sup>, Isabelle Massou<sup>1,6</sup> & Martin Giurfa<sup>1,2,3,6</sup>✉

2957

2958 In the previous chapter, we established a protocol that allowed conditioning tethered bees  
2959 walking stationary to discriminate 3D colored stimuli. With this tool, we can train bees to solve  
2960 a visual task while providing to every insect the same visual experience during conditioning.  
2961 We decided to use our new setup to investigate the brain regions and visual pathways  
2962 underlying visual learning. To do so, we quantified the expression of immediate early genes  
2963 (IEGs) in different brain regions after conditioning. IEGs are considered as useful markers of  
2964 neural activity so that we compared their levels of expression between learners and non-  
2965 learners. Since every bee received the same visual experience in the VR, the main source of  
2966 variability should come from whether or not an individual learned the task. By focusing on  
2967 *kakusei*, *Hr38* and *Egr1*, three IEGs that have been related to bee foraging and orientation, we  
2968 found that, compared to non-learners, learners exhibited *Egr1* upregulation in the calyces of the  
2969 mushroom bodies. This indicates an involvement of mushroom body calyces in associative color  
2970 learning. and the usefulness of *Egr1* as a marker of neural activity induced by this phenomenon.

2971

2972  
 2973  
 2974  
 2975  
 2976  
 2977  
 2978  
 2979  
 2980  
 2981  
 2982  
 2983  
 2984  
 2985  
 2986  
 2987  
 2988  
 2989  
 2990  
 2991  
 2992  
 2993  
 2994  
 2995  
 2996

**Visual learning in a virtual reality environment upregulates immediate early gene expression in the mushroom bodies of honey bees**

**Haiyang Geng<sup>\*1,2</sup>, Gregory Lafon<sup>1\*</sup>, Aurore Avarguès-Weber<sup>1</sup>, Alexis Buatois<sup>1,‡,§</sup>, Isabelle Massou<sup>1,§</sup>, Martin Giurfa<sup>1,2,3§</sup>**

<sup>1</sup> Research Centre on Animal Cognition, Center for Integrative Biology, CNRS, University of Toulouse, 118 route de Narbonne, F-31062 Toulouse cedex 09, France.

<sup>2</sup> College of Animal Sciences (College of Bee Science), Fujian Agriculture and Forestry University, Fuzhou 350002, China.

<sup>3</sup> Institut Universitaire de France, Paris, France (IUF).

\* These authors contributed equally

§ These authors jointly supervised this work

‡ Present address: Institute of Neuroscience and Physiology, Department of Neurochemistry and Psychiatry, University of Gothenburg, Su Sahlgrenska, 41345 Göteborg, Sweden.

**Corresponding author:** Dr. Martin Giurfa

Research Centre on Animal Cognition, CNRS – UPS, 31062 Toulouse cedex 9, France

[martin.giurfa@univ-tlse3.fr](mailto:martin.giurfa@univ-tlse3.fr)

2997 **Subject Areas:** Behavior, Neuroscience

2998 **ABSTRACT**

2999 Free-flying bees learn efficiently to solve numerous visual tasks. Yet, the neural underpinnings  
3000 of this capacity remain unexplored. We used a 3D virtual reality (VR) environment to study  
3001 visual learning and determine if it leads to changes in immediate early gene (IEG) expression  
3002 in specific areas of the bee brain. We focused on *kakusei*, *Hr38* and *Egr1*, three IEGs that have  
3003 been related to bee foraging and orientation, and compared their relative expression in the  
3004 calyces of the mushroom bodies, the optic lobes and the rest of the brain after color  
3005 discrimination learning. Bees learned to discriminate virtual stimuli displaying different colors  
3006 and retained the information learned. Successful learners exhibited *Egr1* upregulation only in  
3007 the calyces of the mushroom bodies, thus uncovering a privileged involvement of these brain  
3008 regions in associative color learning and the usefulness of *Egr1* as a marker of neural activity  
3009 induced by this phenomenon.

3010

3011

3012 **Keywords:** Vision – Visual Learning – Virtual Reality – Honey Bee Brain – Immediate Early  
3013 Genes – *Kakusei* – *Hr38* – *Egr1* – Mushroom Bodies

3014

## 3015 INTRODUCTION

3016 Invertebrate models of learning and memory have proved to be extremely influential to  
3017 determine where and when such experience-dependent plasticity occurs in the nervous system<sup>1-</sup>  
3018 <sup>6</sup>. One of these models is the domestic honey bee *Apis mellifera*, which has been intensively  
3019 investigated for its visual and olfactory learning capacities<sup>5,7,8</sup>. Yet, the knowledge gained on  
3020 the mechanisms of these abilities is disparate. While an extensive body of research has  
3021 accumulated on the neural bases of olfactory learning and memory in bees<sup>9</sup>, practically nothing  
3022 is known about the neural and molecular underpinnings of their visual learning and memory<sup>10,11</sup>.  
3023 This asymmetry is due to the fact that olfactory learning protocols use harnessed bees that learn  
3024 to extend their proboscis to an odorant that has been forward-paired with sucrose water, while  
3025 visual learning protocols use free-flying bees trained to choose a visual target where they collect  
3026 sucrose reward<sup>5,10</sup>. Whilst the harnessing situation of olfactory-learning protocols facilitates the  
3027 use of invasive techniques to record neural activity, the use of bees that commute freely between  
3028 the hive and the experimental site precludes an equivalent access to visual neural circuits.

3029       Virtual-reality (VR) environments constitute a valuable tool to overcome this limitation.  
3030 In such environments, tethered bees walking stationary on a treadmill are exposed to a  
3031 controlled visual environment that allows studying decision making based on visual cues<sup>12-17</sup>.  
3032 Under these conditions, bees learn and memorize simple and higher-order visual discrimination  
3033 problems, which enables coupling the study of this visual learning with mechanistic analyses  
3034 of brain activity<sup>16,17</sup>. VR setups may differ according to the degree of variation introduced by  
3035 the bee movement into the visual environment. In closed-loop conditions, this variation is  
3036 contingent with the movements of a tethered bee, thus creating a more immersive environment.  
3037 In prior works, we introduced a 2D VR environment in which a tethered bee could displace  
3038 laterally (from left to right and vice versa) a color stimulus on a frontal screen according to its  
3039 association with sucrose reward of absence of reward<sup>12,14,18</sup>. Here we moved towards a more

3040 realistic 3D VR environment which allowed, in addition, for stimulus expansions and  
3041 retractions depending on forward or backward movements, respectively. In this arena, bees may  
3042 therefore learn to discriminate colors but can also explore in a less restricted way the virtual  
3043 world proposed to them.

3044         One way to detect brain regions and pathways activated in this scenario is the  
3045 quantification of immediate early genes (IEGs) in neural tissues<sup>19</sup>. IEGs are transcribed  
3046 transiently and rapidly in response to specific stimulations inducing neural activity without *de*  
3047 *novo* protein synthesis<sup>20</sup>. In mammals, IEGs such as *c-fos*, *zif268* and *Arc* are regularly used as  
3048 markers of neural activity during learning, memory and other forms of cellular plasticity such  
3049 as long-term potentiation<sup>21-23</sup>. In insects, the use of IEGs as neural markers is less expanded as  
3050 the number of candidate genes serving this goal is still reduced and the reliable detection of  
3051 their expression is sometimes difficult<sup>24</sup>. Three of the IEGs reported for the honey bee are  
3052 interesting as they have been related to a foraging context in which learning plays a fundamental  
3053 role. The first one, termed *kakusei* (which means ‘awakening’ in Japanese) is a nuclear non-  
3054 coding RNA transiently and strongly induced in the brain of European workers by seizures that  
3055 can be induced by awakening them from anesthesia<sup>25</sup>. It is also activated after the experience  
3056 of dancing in the hive following a foraging flight and in pollen foragers so that it seems related  
3057 to the neural excitation resulting from foraging activities<sup>26</sup>. This IEG is activated within a  
3058 subtype of Kenyon cells, the constitutive neurons of the mushroom bodies, which are a higher-  
3059 order center in the insect brain<sup>27</sup>. A second IEG is the hormone receptor 38 gene (*Hr38*), which  
3060 is a transcription factor conserved among insects and other species including humans<sup>28</sup>, and  
3061 which has been indirectly related to learning and memory in honey bees and other insects<sup>29,30</sup>.  
3062 *Hr38* is also upregulated by foraging experiences in honey bees<sup>29</sup> and bumblebees<sup>30</sup> and by  
3063 orientation activities upon hive displacement<sup>31</sup>. The third gene is the early growth response  
3064 gene-1 (*Egr1*), whose expression is induced in the brain of honey bees and bumble bees upon

3065 foraging<sup>29,30</sup> and orientation flights<sup>32</sup>, and which seems to be controlled by circadian timing of  
3066 foraging<sup>33</sup>. None of these IEGs has been studied so far in the context of associative learning  
3067 and memory formation in the honey bee.

3068 We thus focused on these IEGs to characterize neural activation induced by visual  
3069 learning in the brain of bees under 3D VR conditions. Bees had to learn to discriminate a  
3070 rewarded color from a punished color<sup>34-37</sup> and should retain this information in a short-term  
3071 retention test. Our goal was to determine if successful learning and retention activate  
3072 specifically certain regions in the brain, in particular the mushroom bodies, whose importance  
3073 for olfactory learning and memory has been repeatedly stressed<sup>5,38</sup>, yet with a dramatic lack of  
3074 equivalent evidence in the visual domain. Our results show that successful learners exhibited  
3075 *Egr1* upregulation only in the calyces of the mushroom bodies, thus uncovering a privileged  
3076 involvement of these brain regions in associative color learning.

## 3077 **RESULTS**

### 3078 **Color learning under 3D VR conditions**

3079 Honey bee foragers were captured at an artificial feeder to which they were previously trained  
3080 and brought to the laboratory where a tether was glued on their thorax. (Fig. 1A,B). They could  
3081 be then attached to a holder that allowed adjusting their position on a treadmill, a polystyrene  
3082 ball floating on a constant airflow produced by an air pump (see Methods for details). The VR  
3083 setup consisted of this treadmill placed in front of a semi-cylindrical semi-transparent screen  
3084 made of tracing paper (Fig. 1A). The movements of the walking bee on the treadmill were  
3085 recorded by two infrared optic-mouse sensors placed on the ball support perpendicular to each  
3086 other.

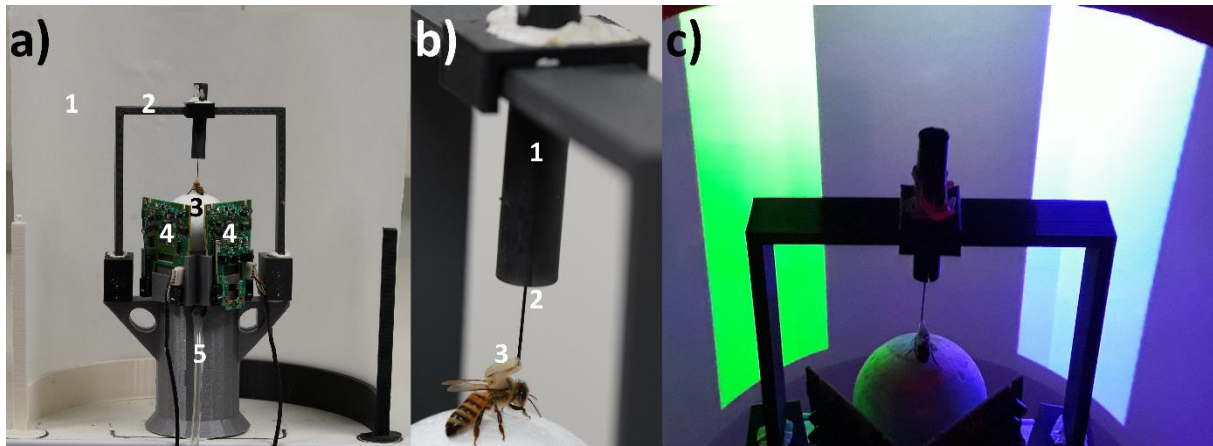

3087

3088 **Figure 1. Experimental setup and 3D environment. A) Global view of the VR system.** 1:  
 3089 Semicircular projection screen made of tracing paper. 2: Holding frame to place the tethered  
 3090 bee on the treadmill. 3: The treadmill was a Styrofoam ball positioned within a cylindrical  
 3091 support (not visible) floating on an air cushion. 4: Infrared mouse optic sensors allowing to  
 3092 record the displacement of the ball and to reconstruct the bee's trajectory. 5: Air arrival. The  
 3093 video projector displaying images on the screen from behind can be seen on top of the image.  
 3094 **B) The tethering system.** 1: Plastic cylinder held by the holding frame; the cylinder contained  
 3095 a glass cannula into which a steel needle was inserted. 2: The needle was attached to the thorax  
 3096 of the bee. 3: Its curved end was fixed to the thorax by means of melted bee wax. **C) Color**  
 3097 **discrimination learning in the VR setup.** The bee had to learn to discriminate two vertical  
 3098 cuboids based on their different color and their association with reward and punishment.  
 3099 Cuboids were green and blue on a dark background. Color intensities were adjusted to avoid  
 3100 phototactic biases independent of learning.

3101

3102 Bees were trained to discriminate a green from a blue vertical cuboid against a black  
 3103 background during ten conditioning trials (Fig. 1C; see Supplementary Fig. 1 for color  
 3104 characteristics). Training consisted in pairing one of the cuboids (CS+) with a rewarding 1 M  
 3105 sucrose solution and the other (CS-) with an aversive 3M NaCl solution<sup>39,40</sup> (Fig. 2). Bees  
 3106 performed equally irrespective of the color trained ( $z = -0.97$ ,  $p = 0.33$ ). They were subdivided  
 3107 according to their test performance to distinguish those which showed successful discrimination  
 3108 (i.e. choice of the CS+; “learners”) from those which did not (“non-learners”). This distinction  
 3109 allowed subsequent brain gene analyses according to learning success. Bees that were unable  
 3110 to choose a stimulus in at least 5 trials were excluded from the analysis. Acquisition was  
 3111 significant for learners ( $n = 17$ ) during conditioning trials (Fig. 3A; CS\**Trial* effect:  $\chi^2 = 33.68$ ,

3112 df:2,  $p < 0.0001$ ), confirming the occurrence of learning. Indeed, the percentages of bees  
3113 responding to the CS+ and to the CS- differed significantly along trials (CS+ vs. CS-: CS\*Trial;  
3114  $z = -5.46$ ,  $p < 0.0001$ ). Significant differences were also found when comparing the percentages  
3115 of non-responding bees against the CS+ responding bees and against the CS- responding bees  
3116 (NC vs. CS+: CS\*Trial;  $z = 8.14$ ,  $p < 0.0001$ ; NC vs. CS-: CS\*Trial;  $z = 4.59$ ,  $p < 0.0001$ ). *Non-*  
3117 *learners* ( $n = 18$ ) did also show a significant interaction (Fig. 3B; CS\*Trial effect:  $\chi^2 = 7.66$ , df:2,  
3118  $p = 0.02$ ), but this was introduced by the percentage of non-responding bees. These bees differed  
3119 significantly along trials both from the bees responding to the CS+ (NC vs. CS+: CS\*Trial;  
3120  $z = 6.10$ ,  $p < 0.0001$ ) and from the bees responding to the CS- (NC vs. CS-: CS\*Trial;  $z = 6.07$ ,  
3121  $p < 0.0001$ ). On the contrary, the percentages of bees responding to the CS+ and to the CS- did  
3122 not vary along trials (CS+ vs. CS-: CS\*Trial;  $z = -0.07$ ,  $p = 1$ ), consistently with the absence of  
3123 learning.

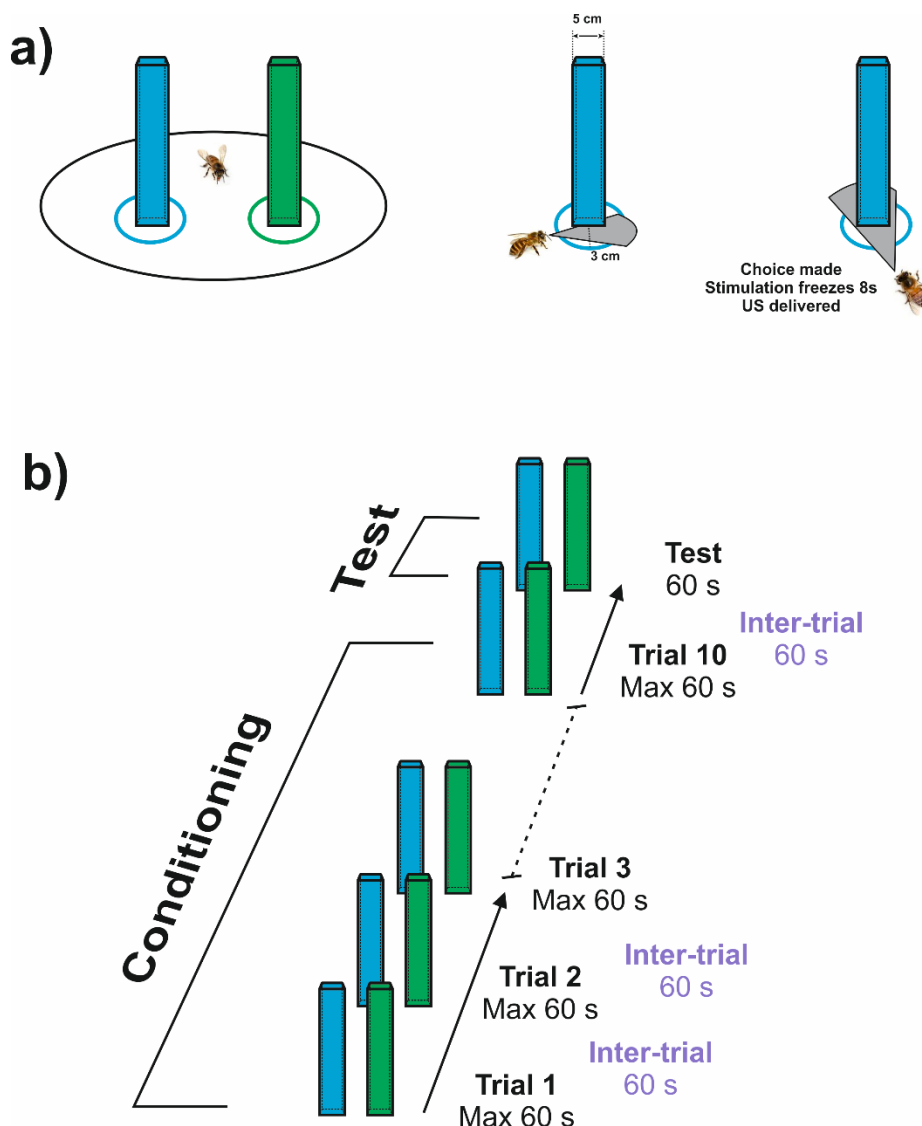

3124

3125 **Figure 2. Choice criterion and conditioning protocol for color discrimination learning. A)**  
 3126 **Choice criterion.** Left: A bee facing the two virtual cuboids. Center: A bee approaching a target  
 3127 cuboid; the cuboid has not yet been centered by the bee (gray area). Right: A bee having  
 3128 centered the target cuboid (gray area). A choice was recorded when the bee reached an area of  
 3129 a radius of 3 cm centered on the cuboid and fixed it frontally. The cuboid image was then frozen  
 3130 during 8 s and the corresponding reinforcement (US) was delivered. **B) Conditioning protocol.**  
 3131 Bees were trained along 10 conditioning trials that lasted a maximum of 1 min and that were  
 3132 spaced by 1 min (intertrial interval). After the end of conditioning, and following an additional  
 3133 interval of 1 min, bees were tested in extinction conditions with the two colored cuboids during  
 3134 1 min.

3135

3136 We next asked if differences between learners and non-learners could be due to  
 3137 differences in motor components. To answer this question, we analyzed for each conditioning  
 3138 trial the total distance walked, the walking speed, and the tortuosity of the trajectories.

3139 Tortuosity was calculated as the ratio between the total distance walked and the distance  
3140 between the first and the last point of the trajectory connected by an imaginary straight line.  
3141 When the ratio was 1, or close to 1, trajectories were straightforward while higher values  
3142 corresponded to sinuous trajectories. The distance travelled (Fig. 4A) did neither vary along  
3143 trials (*Trial*:  $\chi^2=0.24$ , *df*:1, *p*=0.62) nor between *learners* and *non-learners* (*Condition*:  $\chi^2=1.10$ ,  
3144 *df*:1, *p*=0.30; *Condition\*Trials*:  $\chi^2=0.71$ , *df*:1, *p*=0.40). Tortuosity (Fig. 4B) varied along trials  
3145 (*Trial*:  $\chi^2=14.53$ , *df*:1, *p*<0.001) but not between *learners* and *non-learners* (*Condition*:  
3146  $\chi^2=0.08$ , *df*:1, *p*=0.80; *Condition\*Trials*:  $\chi^2=0.42$ , *df*:1, *p*=0.52). Finally, the walking speed (Fig.  
3147 4C) increased significantly along trials (*Trial*:  $\chi^2=30.49$ , *df*:1, *p*<0.0001) but did not vary  
3148 between *learners* and *non-learners* (*Condition*:  $\chi^2=1.43$ , *df*:1, *p*=0.23); in this case, however,  
3149 the interaction between *Trial* and *Condition* was significant ( $\chi^2=4.68$ , *df*:1, *p*<0.05). This  
3150 suggests that *learners* were slower than *non-learners*, which is reminiscent of a speed-accuracy  
3151 trade off reported in numerous experiments in bees<sup>41-43</sup>.

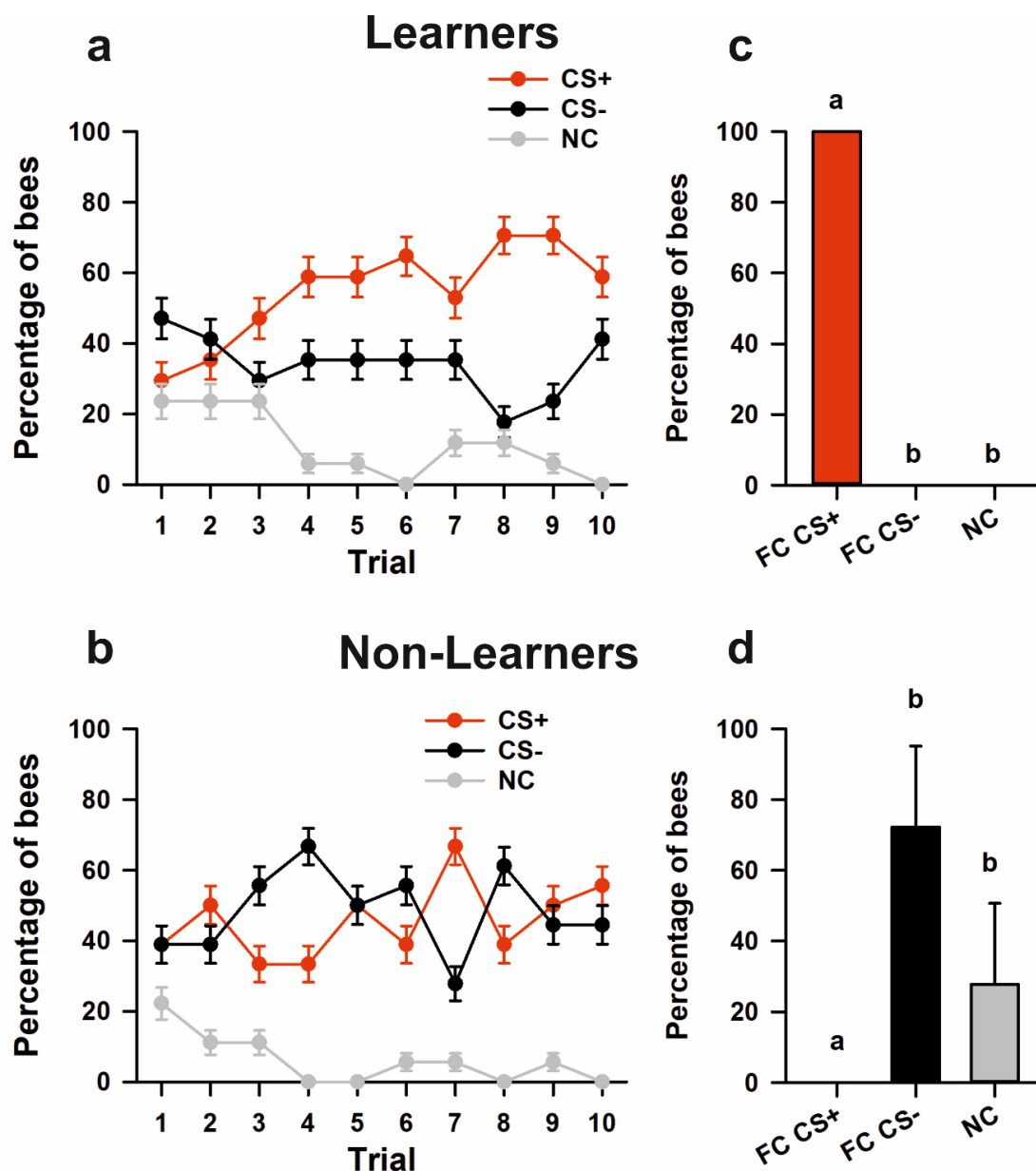

3152

3153 **Figure 3. Discrimination learning in the VR setup. A) Acquisition performance of learners**  
 3154 (i.e. percentage of bees that chose the CS+ in the non-reinforced test; n=17). The red, black and  
 3155 grey curves show the percentages of bees choosing the CS+, the CS- or not making a choice  
 3156 (NC), respectively. Bees learned the discrimination between CS+ and CS-. **B) Acquisition**  
 3157 **performance of non-learners** (i.e. percentage of bees that chose the CS- or did not make a  
 3158 choice in the non-reinforced test; n=18). These bees did not learn to discriminate the CS+ from  
 3159 the CS-. **C) Test performances of learners.** Percentage of bees choosing in their first choice  
 3160 the CS+ (FC CS+), the CS- (FC CS-) or not making a choice (NC). Per definition, *learners*  
 3161 chose the CS+ in this test. Different letters on top of bars indicate significant differences  
 3162 (GLMM;  $p < 0.05$ ). **D). Test performances of non-learners.** Percentage of bees choosing in  
 3163 their first choice the CS+ (FC CS+), the CS- (FC CS-) or not making a choice (NC). Per  
 3164 definition, *non-learners* did not choose the CS+. Different letters on top of bars indicate  
 3165 significant differences (GLMM;  $p < 0.05$ ). In all panels, error bars indicate the 95% confidence  
 3166 interval.

3167

3168           Finally, in the non-reinforced test, per definition *learners* (n=17; Fig. 3C) chose  
3169 correctly the CS+ (100% of the bees) while *non-learners* (n=18; Fig. 3D) did either chose the  
3170 CS- (72.22%) or did not perform any choice (27.78%). We thus focused on differences between  
3171 *learners* and *non-learners* in the subsequent IEG analyses to uncover possible changes in neural  
3172 activity induced by learning.

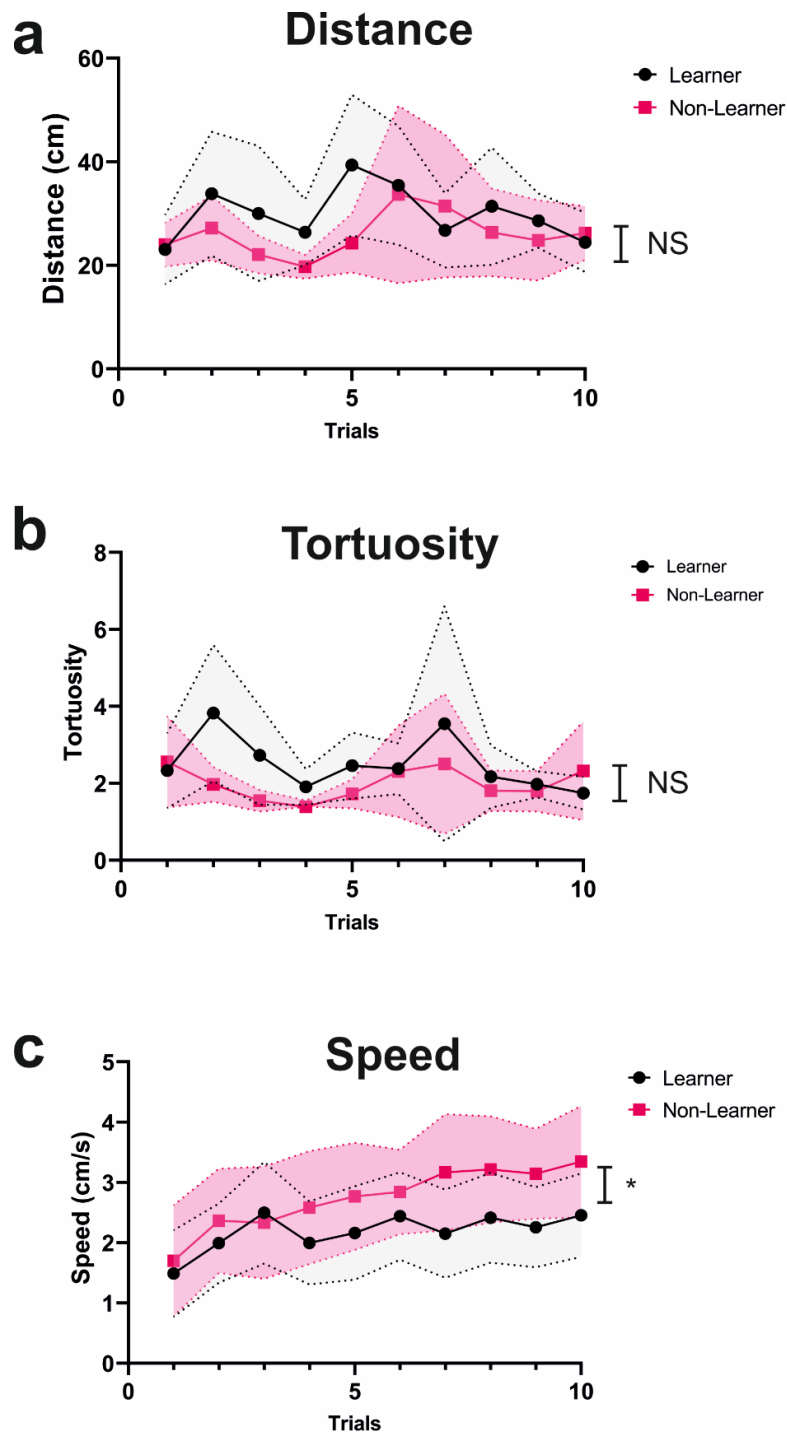

3173

3174

3175 **Figure 4. Motor components of learners (n=17) and non-learners (n = 18) in the VR setup**  
 3176 **during conditioning. A) Distance travelled (cm) during each conditioning trial. B) Tortuosity**  
 3177 **of the trajectories (see text for explanation) during each conditioning trial. C) Walking speed**  
 3178 **(cm/s) during each conditioning trial. The dashed lines above and below the curves represent**  
 3179 **the 95% confidence interval. Comparisons between curves refer to the significance of the**  
 3180 **interaction between the factors *Trial* (1 to 10) and *Condition* (*learners vs. non-learners*). All**  
 3181 **comparisons referring to *Condition* alone were non-significant. LMM; \*:  $p < 0.05$ ; NS: non-**  
 3182 **significant.**

3183

Type of gene	Target	Primer sequence 5' ➤3'	Amplicon length (bp)	E (%)	R <sup>2</sup>
Target genes	<i>Kakusei</i>	CTACAACGTCCTCTTCGATT (forward) CCTACCTTGGTATTGCAGTT (reverse)	149	96.4	0.991
	<i>Hr38</i>	TGAGATCACCTGGTTGAAAG (forward) CGTAGCAGGATCAATTTCCA (reverse)	118	106	0.995
	<i>Egr1</i>	GAGAAACCGTTCTGCTGTGA (forward) GCTCTGAGGGTGATTTCTCG (reverse)	138	109	0.991
Reference genes	<i>Efl</i> $\alpha$	AAGAGCATCAAGAGCGGAGA (forward) CACTC TTAATGACGCCACA (reverse)	148	106	0.993
	<i>Actin</i>	TGCCAACACTGTCCTTTCTG (forward) AGAATTGACCCACCAATCCA (reverse)	156	110	0.995

3184 **Table 1.** Primer sequences used to quantify RNA expression of genes of interest and reference  
3185 genes by RT-qPCR. Amplicon length (bp), efficiency (E, %) and the coefficient of correlation  
3186 obtained for the standard curve (R<sup>2</sup>) are also shown. *Hr38*: Hormone receptor 38 gene; *Egr1*:  
3187 Early growth response gene-1; *Efl*  $\alpha$ : Elongation factor 1  $\alpha$  gene.

3188

### 3189 IEG analyses in the honey bee brain following color learning under 3D VR conditions

3190 We aimed at determining if visual learning in VR induces post learning transcriptional changes,  
3191 which might participate in amplifying neural activity reflecting associative color learning. To  
3192 this end, we performed RT-qPCR in individual brains of *learners* and *non-learners*, which were  
3193 collected 1h after the retention test and placed in liquid nitrogen until brain dissection. We  
3194 analyzed relative expression levels of *kakusei*, *Hr38* and *Egr1* (see [Table 1](#)) in three main brain  
3195 regions<sup>44</sup> ([Fig. 5A](#)): the optical lobes (OL), the upper part of the mushroom bodies (i.e. the  
3196 mushroom-body calyces or MB Ca) and the remaining central brain (CB), which included  
3197 mainly the central complex, the subesophageal zone and the peduncula and lobes ( $\alpha$  and  $\beta$   
3198 lobes) of the mushroom bodies. Two reference genes were used for the normalization, *Efl*  $\alpha$   
3199 (E=106%) and *Actin* (E=110%), which proved to be the best choice for the normalization (see  
3200 [Table 1](#)). The Cq values of these reference genes for the different conditions of this experiment

3201 are shown in [Supplementary Fig. 2](#). Stability was granted for both genes and experimental  
3202 groups (*learners* and *non-learners*) for the MB and the CB. In the case of the OL, *Efl $\alpha$*  varied  
3203 significantly between groups. Thus, normalization used the product of the two reference genes  
3204 for MB and CB while only actin could be used to normalize OL data. No cross-comparisons  
3205 between brain regions or genes were performed.

3206 [Figure 5 B-D](#) shows the relative normalized expression of *kakusei* for the three brain  
3207 regions considered in the case of *learners* and *non-learners*. No significant variations of relative  
3208 expression were found between these two groups for the three regions considered (two-sample  
3209 t test; [Fig. 5B](#), OL:  $t_{29}=0.83$ ,  $p=0.42$ ; [Fig. 5C](#), MB:  $t_{29}=1.09$ ,  $p=0.29$ ; [Fig. 5D](#), CB:  $t_{29}=1.04$ ,  
3210  $p=0.31$ ). Thus, *kakusei* was unable to reveal learning-induced variations in neural activity under  
3211 our experimental conditions. The normalized expression of *Hr38* ([Fig. 5 E-G](#)) was also  
3212 insufficient to uncover learning related differences between *learners* and *non-learners* ([Fig. 5E](#),  
3213 OL:  $t_{29}=0.37$ ,  $p=0.72$ ; [Fig. 5F](#), MB:  $t_{29}=0.99$ ,  $p=0.33$ ; [Fig. 5G](#), CB:  $t_{29}=0.44$ ,  $p=0.67$ ). However,  
3214 a significant upregulation of *Egr1* expression was found in the mushroom bodies of *learners*  
3215 when compared to *non-learners* ([Fig. 5I](#),  $t_{29}=2.40$ ,  $p=0.02$ ). Differences in *Egr1* expression  
3216 between *learners* and *non-learners* were neither found in the OL ([Fig. 5H](#),  $t_{29}=1.48$ ,  $p=0.15$ )  
3217 nor in the CB ([Fig. 5J](#),  $t_{29}=0.17$ ,  $p=0.86$ ), thus showing that learning-dependent variation in IEG  
3218 expression was circumscribed to the calyces of the mushroom bodies and that *Egr1* was more  
3219 sensitive than both *Hr38* and *kakusei* to detect changes in neural activity induced by associative  
3220 learning.

3221

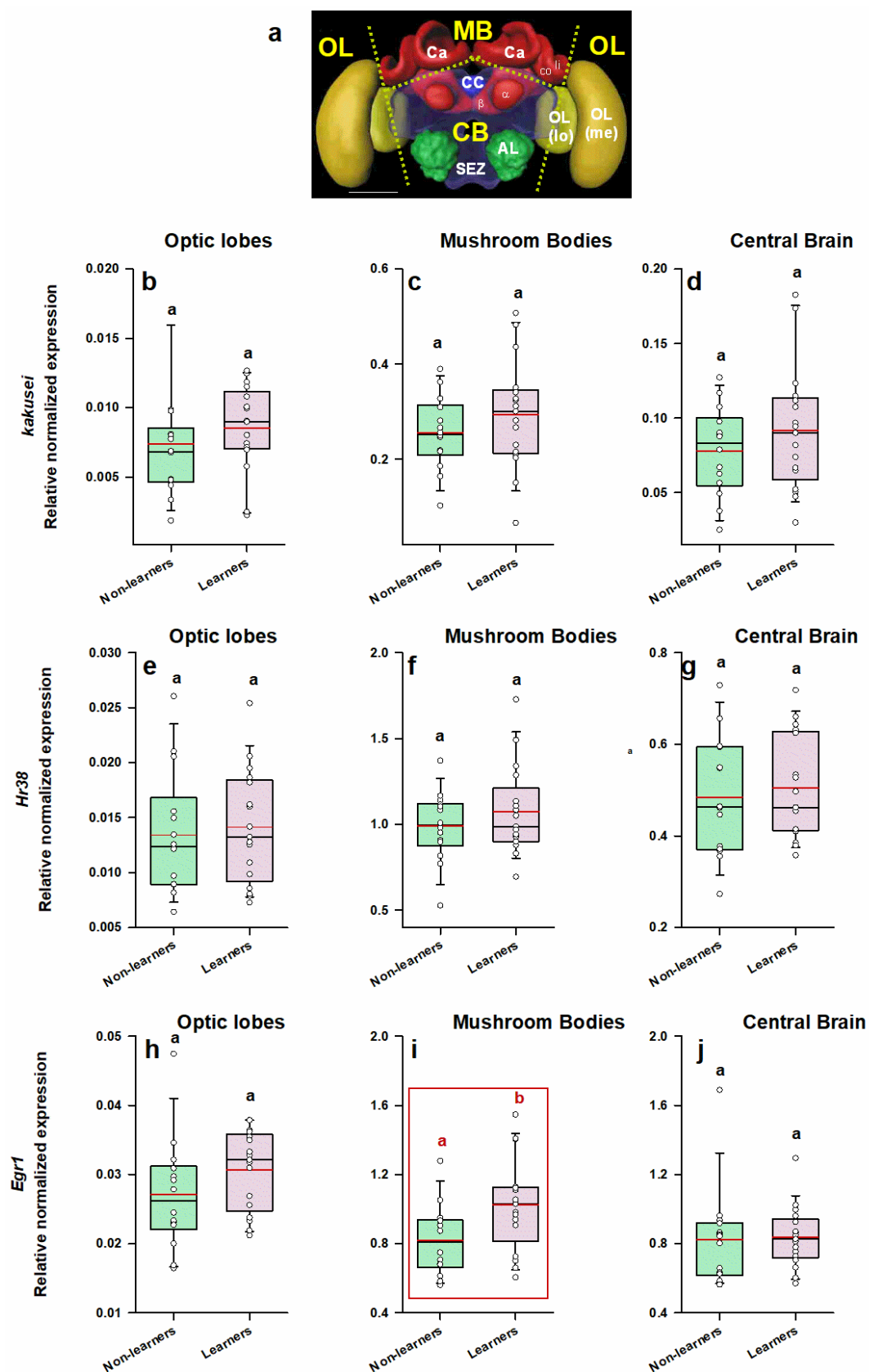

3222

3223 **Figure 5. *Egr1*, but neither *kakusei* nor *Hr38*, shows significant variation of relative**  
 3224 **expression in the mushroom bodies following visual associative learning in a 3D VR**  
 3225 **environment. A) Honey bee brain with sections used for quantifying IEG expression.**

3226 Yellow labels indicate the brain regions used for the analysis: MB: mushroom body; CB: central  
 3227 brain; OL: optic lobes. The dashed lines indicate the sections performed. Ca: calyx of the  
 3228 mushroom body; li: lip; co: collar; □ and □: □□ and □□ lobes of the mushroom body; CC:  
 3229 central complex; AL: antennal lobe; SEZ: subesophagic zone; OL: optic lobe; Me: medulla; lo:  
 3230 lobula. **(B-D) Relative normalized expression of *kakusei*, of *Hr38* (E-G) and of *Egr1* (H-J)**  
 3231 **in three main regions of the bee brain, the optic lobes (B, E, H), the calyces of the**  
 3232 **mushroom bodies (C, F, I) and the central brain (D, G, J).** The expression of each IEG was  
 3233 normalized to the expression of two genes of reference (*Actin* and *Ef1*) in the case of the MB  
 3234 and the CB, and of *Actin* alone in the case of the OL (see [Supplementary Figure 2](#)). The range  
 3235 of ordinates was varied between target genes to facilitate appreciation of data scatter. IEG  
 3236 expression was analyzed in individual brains of bees belonging to two categories: *learners*  
 3237 (conditioned bees that responded correctly and chose the CS+ in their first choice during the  
 3238 non-reinforced test; n=17) and *non-learners* (conditioned bees that did not choose the CS+ in  
 3239 their first choice during the non-reinforced test; n=14). The range of ordinates was varied  
 3240 between target genes to facilitate appreciation of data scatter. Box plots show the mean value  
 3241 in red. Error bars define the 10<sup>th</sup> and 90<sup>th</sup> percentiles. Red boxes indicate cases in which  
 3242 significant variations were detected. Different letters on top of box plots indicate significant  
 3243 differences (two-sample t test;  $p < 0.05$ ).

3244

## 3245 DISCUSSION

3246 Our work shows that visual discrimination learning under virtual-reality conditions leads to an  
 3247 enhancement of IEG expression in the case of *Egr1* in the calyces of the mushroom bodies in  
 3248 successful honey bee learners. Learning success did not correlate with differences in distance  
 3249 travelled or tortuosity of trajectories, i.e. with differences in exploratory drive ([Fig. 4](#)), but was  
 3250 correlated with differences in walking speed as *learners* tended to be slower than *non-learners*.  
 3251 Although strictly speaking the two categories did not differ with respect to this parameter, the  
 3252 significant interaction between *Trial* and *Condition* suggests a speed-accuracy trade off in  
 3253 which individuals taking more time to decide can improve the accuracy of their decisions<sup>41-43</sup>.  
 3254 Differences in *Egr1* expression were thus related to learning success and not to differences in  
 3255 exploratory components. For the other two IEGs analyzed, *kakusei* and *Hr38*, no learning-  
 3256 dependent changes could be detected in the different brain regions considered, even if prior  
 3257 reports indicated similar levels of expression for the three IEGs in the brain of bees engaged in

3258 foraging<sup>29,30,33,45</sup> and orienting around the hive<sup>29-31</sup>. Our work demonstrates therefore that this  
3259 similarity does not necessarily reflect a relationship with associative learning and memory as  
3260 only *Egr1* acted as *bona fide* marker of learning success in the bee brain under our experimental  
3261 conditions and revealed the implication of the calyces of the mushroom bodies in associative  
3262 visual learning and memory in honey bees.

3263

### 3264 **Differential expression of IEGs in the honey bee brain as related to visual learning**

3265 *Kakusei* did not vary in the brain regions considered, under the experimental conditions defined  
3266 in our work. This IEG does not have orthologous genes in other taxa and its role in honey bees  
3267 is unclear. It is induced by seizures following anesthesia<sup>25,27,45,46</sup> and thermal stimulation<sup>46</sup>, but  
3268 also by foraging and reorientation activity following hive displacement<sup>25,31,45</sup>. These  
3269 experiences increase *kakusei* expression in the mushroom bodies<sup>25</sup> but also in the optic  
3270 lobes<sup>25,27,45</sup> and the dorsal lobe<sup>27</sup>. Our results suggest that its enhanced expression in foragers  
3271 or in orienting bees is not necessarily related to learning occurring in these contexts.

3272         Differential expression of *kakusei* with respect to an inducing treatment (typically, an  
3273 induced seizure) starts around 15 min post treatment<sup>25,31,46</sup> but continues during longer periods  
3274 which may go beyond 60 min<sup>46</sup>. Thus, the waiting time of 60 min between test and brain  
3275 freezing in our experiments was appropriate to detect changes in *kakusei* as a result of  
3276 associative visual learning. However, as other temporal analyses of *kakusei* expression reported  
3277 a decay in expression beyond 30 min<sup>25</sup>, the possibility that our sampling period was too long to  
3278 capture changes in *kakusei* expression cannot be excluded.

3279         This concern does not apply to *Hr38* and *Egr1*, for which temporal expression analyses  
3280 showed a systematical increase at the time chosen for our experiments<sup>30</sup>. As in the case of  
3281 *kakusei*, no learning-related changes were detected in *Hr38* expression across the brain regions  
3282 considered. This hormone receptor gene has been indirectly related to learning and memory in  
3283 honey bees and other insects<sup>29,30</sup> and is also upregulated by foraging experiences in honey bees<sup>29</sup>

3284 and bumblebees<sup>30</sup> and by orientation activities upon hive displacement<sup>31</sup>. Despite its  
3285 involvement in these activities, it did not reveal learning-dependent changes in neural activity  
3286 in the experimental context defined by our setup and training protocol.

3287         Only *Egr1* reported a significant variation in the mushroom body calyces of *learners* in  
3288 relation to *non-learners* (Fig. 5). As for the two other IEGs, the expression of this early growth  
3289 response gene is enhanced in the brain of honey bees and bumblebees upon foraging<sup>29,30</sup> and  
3290 orientation flights<sup>32</sup>. Yet, in this case, *Egr1* was sensitive enough to report differences in neural  
3291 activity related to learning success in our experimental conditions. *Learners* and *non-learners*  
3292 were identical in their experience and handling all along the experiment and they only differed  
3293 in learning success. Thus, differences in *Egr1* expression demonstrate that associative color  
3294 learning is accompanied by increased neural activity in the calyces of the mushroom bodies.

3295

### 3296 **The role of mushroom bodies for visual learning and memory**

3297 Although the crucial role of mushroom bodies for the acquisition, storage and retrieval of  
3298 olfactory memories has been extensively documented in bees<sup>7,38,47</sup> and other insect species<sup>2,3,48</sup>,  
3299 less is known about their implication in visual learning and memory. In the honey bee, the fact  
3300 that visual learning was mainly studied using free-flying bees trained to choose visual targets  
3301 precluded its study at the cellular level<sup>13</sup>. The neural circuits for color processing are known in  
3302 the bee brain<sup>49-52</sup> but evidence about plasticity-dependent changes in these circuits remains  
3303 scarce. Such changes could occur at multiple stages, as is the case in olfactory circuits mediating  
3304 olfactory learning<sup>9</sup>. Upstream the mushroom bodies, inner-layer lobula and inner medulla  
3305 neurons project to both the mushroom bodies and the lateral protocerebrum<sup>49,50,53</sup> and exhibit  
3306 color sensitivity, color opponency and temporally complex patterns including adaptation and  
3307 entrainment<sup>49,53,54</sup>. These patterns are important for color coding and discrimination and could  
3308 be subjected to experience-dependent changes in activity<sup>55</sup>.

3309           The implication of mushroom bodies in visual learning and memory in the bee is  
3310 expected given the parallels between visual and olfactory inputs at the level of the calyces.  
3311 Whilst afferent projection neurons convey olfactory information to a subdivision of the calyces,  
3312 the lip<sup>56</sup>, afferent neurons from the lobula and the medulla, which are part of the optic lobes,  
3313 convey visual information to other calyx subdivisions, the collar and the basal ring<sup>50,57</sup>. In spite  
3314 of this similarity, studies addressing the role of mushroom bodies in honey bee visual learning  
3315 and memory remain rare. The recent development of protocols for the study of *aversive* visual  
3316 learning (association between a color light and an electric shock delivered to walking bees  
3317 enclosed in a box compartment)<sup>44,58</sup> has showed the possible implication of mushroom bodies  
3318 in this form of learning. In a pharmacological study, in which one half of a chamber was  
3319 illuminated with one color and paired with shock while the other half was illuminated with a  
3320 different color not paired with shock, bees learned to escape the shock-paired light and spent  
3321 more time in the safe light after a few trials<sup>59</sup>. When ventral lobe neurons of the mushroom  
3322 bodies were silenced by procaine injection, bees were no longer able to associate one light with  
3323 shock. By contrast, silencing one collar region of the mushroom body calyx did not alter  
3324 behavior in comparison with that of controls<sup>59</sup>. The latter result does not exclude a role for the  
3325 calyces in visual learning, as blocking one of four collar regions may not have a significant  
3326 impact on learning. In a different study, bees were trained to inhibit their spontaneous  
3327 phototaxis by pairing the attracting light with an electric shock<sup>44</sup>. In this case, learning induced  
3328 an increase in the dopaminergic receptor gene *Amdop1* in the calyces of the mushroom bodies,  
3329 consistently with the role of dopaminergic signaling for electric-shock representation in the bee  
3330 brain<sup>60,61</sup>.

3331           In the fruit fly, the study of the role of mushroom bodies for visual learning and memory  
3332 has yielded contradictory results. Flies suspended within a flight simulator learn to fly towards  
3333 unpunished visual landmarks to avoid heat punishment delivered to their thorax; mushroom

3334 body deficits do not affect learning so that these structures were considered dispensable for  
3335 visual learning and memory<sup>62</sup>. Similarly, learning to discriminate colors in a cylindrical  
3336 container made of a blue-lit and a yellow-lit compartment, one of which was associated with  
3337 aversive shaking, was not affected in mushroom body mutants<sup>63</sup>. Visual place learning by flies  
3338 walking within a cylindrical arena displaying landmarks can also take place in the absence of  
3339 functional mushroom bodies but requires the central complex<sup>64</sup>. Yet, the dispensability of  
3340 mushroom bodies for visual learning and memory in fruit flies has been questioned by  
3341 experiments in which appetitive and aversive color learning and discrimination were studied in  
3342 an arena in which blue and green colors were presented from below. Walking flies learned both  
3343 the appetitive (based on pairing one color with sugar) and the aversive discrimination (based  
3344 on pairing one color with electric shock) but failed if mushroom body function was blocked  
3345 using neurogenetic tools<sup>65</sup>. Thus, the role of mushroom bodies for visual learning and memory  
3346 in fruit flies may be both task- and learning specific. In addition, the dominance of olfactory  
3347 inputs to the mushroom bodies may overshadow their role for visual learning in *Drosophila*.

3348

### 3349 **IEG expression within the mushroom bodies in relation to visual learning**

3350 Kenyon cells are the constitutive neurons of the mushroom bodies. Their somata are located  
3351 both within the mushroom-body calyces and adjacent to them. Thus, our brain sectioning (see  
3352 [Fig. 4A](#)) collected them massively. Detecting IEG activation in the mushroom bodies upon  
3353 visual learning may be particularly difficult as learning-dependent changes in neural activity  
3354 may be subtle due to the characteristic sparse neural activity observed at the level of the calyces.  
3355 This reduced activity, which has been revealed in studies on olfactory coding<sup>66-68</sup> and odor-  
3356 related learning<sup>69</sup>, can also be a hallmark of visual processing and visual learning. Sparse neural  
3357 coding of odorants is in part due to GABAergic inhibition by feedback extrinsic mushroom-  
3358 body neurons acting on Kenyon cells<sup>70,71</sup>, the constitutive neurons of the mushroom bodies.

3359 These GABAergic neurons, present both in bees and flies<sup>70,72,73</sup>, suppress Kenyon cell activity  
3360 to maintain sparse, neural coding, and may render difficult detecting variations of IEG  
3361 expression in the calyces. Yet, we were able to find differences that were dependent on the  
3362 experience of the animals analyzed. Such differences might vary according to the difficulty of  
3363 the learning problem considered. For instance, higher GABAergic input is required in the  
3364 calyces to solve non-linear discriminations, in which subjects have to inhibit response  
3365 summation to the simultaneous presentation of stimuli A and B, which are rewarded when  
3366 presented alone but non-rewarded when presented together. Bees that learn to solve this  
3367 discrimination in the olfactory domain require inhibitory GABAergic feedback in the calyces  
3368 to this end<sup>47</sup>. Such a requirement could translate into a different form of IEG expression in this  
3369 brain region as a consequence of a more complex discrimination learning.

3370         Recent work on gene expression in the Kenyon-cells of honey bees revealed the  
3371 existence of various cell subtypes/populations with unique gene expression profiles and cell  
3372 body morphology<sup>74</sup>. Among these populations, small Kenyon cells (sKC)<sup>75</sup>, formerly called  
3373 inner Kenyon cells<sup>76</sup>, are found in the central, inner core of the MB calyces and express  
3374 preferentially three genes, *EcR*, *E74* and *Hr38*, the latter being higher in the brain of foragers  
3375 than in nurses<sup>74</sup>. Unfortunately, no information on *Egr1* was reported in this analysis. Yet,  
3376 another study that did not distinguished between Kenyon-cell subtypes reported that the  
3377 expression of *Egr1* is enriched in Kenyon cells compared to the rest of the brain<sup>32</sup> and that this  
3378 enrichment might be related to learning and memory given its association with the orientation  
3379 flights of bees<sup>32</sup> and with foraging activities<sup>29,30,77</sup>. However, the sensory cues and behavioral  
3380 programs participating in both foraging and orientation are multiple so that it is difficult to  
3381 sustain such a claim in the absence of a controlled learning experiment. For instance, *Egr1* is  
3382 also upregulated in the brain of honey bees upon seizure induction<sup>78</sup>, with no relation to foraging

3383 or orientation. Only specific experiments like the one performed in this work can reveal whether  
3384 increases in this and other IEGs reflect neural activity induced by associative learning.

3385 Consistently with the notion that sKCs may be particularly relevant for learning and  
3386 memory formation, phosphorylated (activated) cAMP-response element binding protein  
3387 (pCREB) is enriched in these sKCs in the honey bee<sup>79</sup>. CREB is a nuclear protein that modulates  
3388 the transcription of genes required for the cellular events underlying long-term memory (LTM)  
3389 formation in both invertebrates and vertebrates<sup>80-83</sup> and its activation leads also to the expression  
3390 of IEGs. It is thus possible that the increased expression of *Egr1* induced by visual learning and  
3391 memory formation is localized within sKCs, and that this increase results from CREB  
3392 activation. In our experiments, the reinforced tests were done shortly after the last conditioning  
3393 trial and only one hour elapsed since the end of the test and the collection of brains for IEG  
3394 analysis (a time necessary for the expression of the IEGs selected). This period does not  
3395 correspond with the temporal requirements for olfactory LTM formation in the standard view  
3396 of memory dynamics in the honey bee, where a protein-synthesis dependent LTM is expected  
3397 after 24-h post conditioning<sup>84</sup>. However, recent work on olfactory memory formation has shown  
3398 that protein-synthesis dependent memories arise much earlier and with less conditioning trials  
3399 than previously thought<sup>85</sup>. Whether our visual conditioning leads to protein-synthesis dependent  
3400 LTM, mediated by CREB activation, remains to be determined.

3401 Taken together, our results show both the implication of mushroom bodies in appetitive  
3402 visual learning in honey bees and the usefulness of *Egr1* as a marker of neural activity induced  
3403 by these phenomena under our experimental conditions. The learning success in our VR setup  
3404 was 50%, which contrasts with the higher learning rates observable for similar color  
3405 discriminations in the case of free-flying bees. This decrease may be due to several reasons  
3406 such as the impossibility to return to the hive between rewarded experiences, the tethering  
3407 conditions and the resulting reduction in active vision. As the tethering impedes, in part, free

3408 movements, it may affect the possibility of actively scanning the images perceived, impairing  
3409 thereby the possibility of extracting target information and learning. In spite of these  
3410 restrictions, our setup allowed to segregate between *learners* and *non-learners* and achieve  
3411 relevant analyses to answer questions on the neural and molecular underpinnings of associative  
3412 visual learning. It constitutes therefore a valuable tool for further studies on the mechanisms of  
3413 visual cognition in bees.

3414         The protocol used to train the bees in our work consisted in an elemental discrimination  
3415 between a rewarded and non-rewarded color. Yet, bees are well known for remarkable visual  
3416 performances, which include the non-elemental learning of concepts and relational rules<sup>86-88</sup>. It  
3417 is therefore possible that different forms of learning, which recruit different brain regions<sup>47</sup>,  
3418 may reveal experience-dependent neural activation through different IEGs and with different  
3419 temporal dynamics. Moreover, IEG upregulation may not always be the hallmark of successful  
3420 learning as in some cases inhibition of neural activity may be crucial for plastic changes in  
3421 behavior. Thus, addressing if IEG expression varies qualitatively and quantitatively according  
3422 to learning type and complexity is of fundamental importance. Furthermore, including different  
3423 intervals post conditioning is important to characterize possible activity changes related to the  
3424 formation of different memory phases in different regions of the bee brain. Last, but not least,  
3425 our results highlight the value of virtual-reality conditions for further explorations of the neural  
3426 and molecular underpinnings of visual learning and memory in bees.

3427

## 3428 **METHODS**

3429 Honey bee foragers (*Apis mellifera*) were obtained from colonies located in our apiary at the  
3430 University Paul Sabatier. Only foragers caught upon landing on a gravity feeder filled with a  
3431 0.9 M sucrose solution were used in our experiments to ensure high appetitive motivation.  
3432 Captured bees were brought to the laboratory where they were placed on ice for five minutes to

3433 anesthetize them and facilitate the fixation of a tether glued to their thorax by means of melted  
3434 wax (Fig. 1A). After being attached to the tether, each bee was placed on a small (49 mm  
3435 diameter) Styrofoam ball for familiarization with the treadmill situation. Bees were provided  
3436 with 5  $\mu$ l of 1.5 M sucrose solution and kept for 3 h in this provisory setup in the dark. They  
3437 were then moved to the VR arena and used for the experiments.

3438         Once in the VR setup, the bee was attached to a holder that allowed adjusting its position  
3439 on the treadmill (Fig. 1B), a polystyrene ball (diameter: 5 cm, weight: 1.07 g) held by a 3D-  
3440 printed support and floating on a constant airflow produced by an air pump (airflow: 555ml/s;  
3441 Aqua Oxy CWS 2000, Oase, Wasquehal, France).

3442

#### 3443 **VR setup**

3444 The VR setup consisted of the treadmill and of a half-cylindrical vertical screen made of semi-  
3445 transparent tracing paper, which allowed presentation of a 180° visual environment to the bee  
3446 (diameter: 268 mm, height: 200 mm, distance to the bee: 9 cm Fig. 1AB) and which was placed  
3447 in front of the treadmill. The visual environment was projected from behind the screen using a  
3448 video projector connected to a laptop (Fig. 1A). The video projector was an Acer K135 (Lamp:  
3449 LED, Definition: 1280 x 800, Brightness: 600 lumens, Contrast ratio: 10 000:1, Minimum  
3450 Vertical Sync: 50 Hz, Maximum Vertical Sync: 120 Hz, Minimum Horizontal Sync: 30.10<sup>3</sup> Hz,  
3451 Maximum Horizontal Sync: 100.10<sup>3</sup> Hz)<sup>14</sup>. The movements of the walking bee on the treadmill  
3452 were recorded by two infrared optic-mouse sensors (Logitech M500, 1000 dpi, Logitech,  
3453 Lausanne, Switzerland) placed on the ball support perpendicular to each other.

3454         Experiments were conducted under 3D closed-loop conditions, i.e. rotations of the ball  
3455 displaced the visual stimuli not only laterally but also towards the bee. To generate these  
3456 conditions, we developed a custom software by means of the Unity engine (version  
3457 2018.3.11f1). The open-source code is available at <https://github.com/G-Lafon/BeeVR>. The

3458 software updated the position of the bee within the VR every 0.017 s. A displacement of 1 cm  
3459 on the ball corresponds to an equivalent displacement in the VR landscape. Moving 1 cm on  
3460 the ball towards an object increased the visual angle of the object by ca. 1.7°. Based on the ball  
3461 movements, our software calculated the position of the walking bee and its heading, and  
3462 determined which object was centered on the screen.

3463

### 3464 **Visual stimuli**

3465 Bees had to discriminate two vertical cuboids ([Fig. 1C](#)) based on their different colors and  
3466 association with reward and punishment. The colors of the cuboids (see [Supplementary Fig. 1](#))  
3467 were blue (RGB: 0, 0, 255, with a dominant wavelength of 450 nm and an irradiance of 161000  
3468  $\mu\text{W}$ ) and green (RGB: 0, 100, 0, with a dominant wavelength of 530 nm and an irradiance of  
3469 24370  $\mu\text{W}/\text{cm}^2$ ). They were displayed on a black background (RGB: 0, 0, 0). These colors were  
3470 chosen based on previous work showing their successful learning in the VR setup<sup>14</sup>.

3471 Each cuboid had a 5×5 cm base and 1 m height so that it occupied the entire vertical  
3472 extent of the screen irrespective of the bee's position. The cuboids were positioned at -50° and  
3473 +50° from the bee's body axis at the beginning of each trial. Approaching a cuboid within an  
3474 area of 3 cm surrounding its virtual surface followed by direct fixation of its center was recorded  
3475 as a choice ([Fig. 2A](#)).

3476

### 3477 **Conditioning and testing at the treadmill**

3478 Bees were trained using a differential conditioning, which promotes better learning  
3479 performances owing to the presence of penalized incorrect color choice that result in an  
3480 enhancement of visual attention<sup>36</sup>.

3481 Bees were trained during 10 consecutive trials using a differential conditioning  
3482 procedure ([Fig. 2B](#)) in which one of the cuboids (i.e. one of the two colors, green or blue) was  
3483 rewarded with 1.5 M sucrose solution (the appetitive conditioned stimulus or CS+) while the

3484 other cuboid displaying the alternative color (the aversive conditioned stimulus or CS-) was  
3485 associated with 3 M NaCl solution. The latter was used to increase the penalty of incorrect  
3486 choices<sup>40,89,90</sup>. To avoid directional biases, the rewarded and the punished color cuboids were  
3487 swapped between the left and the right side of the virtual arena in a pseudo random manner  
3488 along trials. Moreover, a reconstruction of the trajectories of the bees analyzed did not show  
3489 side biases.

3490 A dark screen was shown initially to the bees. During training trials, each bee faced the  
3491 two cuboids. The bee had to choose the CS+ cuboid by walking towards it and centering it on  
3492 the screen. Colors were equally and randomly assigned to the CS+ and the CS- category during  
3493 training. If the bee reached the CS+ within an area of 3 cm in the virtual environment (i.e. if the  
3494 cuboid chosen by the bee subtended 53° in its horizontal extent) and centered it, the screen was  
3495 locked during 8 s to ensure fixation. This allowed the delivery of sucrose solution in case of a  
3496 correct choice, or of NaCl in case of an incorrect choice. Solutions were delivered for 3 s by  
3497 the experimenter who sat behind the bee and used a toothpick to this end. The toothpick touched  
3498 first the antennae and then the mouthparts during the 8 s in which the screen was locked on the  
3499 cuboid fixated by the bee. Each training trial lasted until the bee chose one of both stimuli or  
3500 for a maximum of 60 s (no choice). Trials were separated by an inter-trial interval of 60 s during  
3501 which the dark screen was presented. Bees that were unable to choose a stimulus (i.e. that did  
3502 not fulfill the criterion of a choice defined above) in at least 5 trials were excluded from the  
3503 analysis. From 216 bees trained, 75 were kept for analysis (~35%).

3504 After the last training trial, each bee was subjected to a non-reinforced test that lasted  
3505 60 s (Fig. 2B). Test performance allowed distinguishing *learners* (i.e. bees that chose the CS+  
3506 as their first choice in the test) from *non-learners* (i.e. bees that either chose the CS- in their  
3507 first test choice or that did not make any choice during the test). IEG expression was compared

3508 between these two groups, which had the same sensory experience in the VR setup and which  
3509 differed only in their learning success.

3510

### 3511 **Brain dissection**

3512 One hour after the test, bees were decapitated, and the head was instantly frozen in a nitrogen  
3513 solution. The period between post-test and brain collection was chosen to allow induction of  
3514 the three IEGS studied (typically, 15 or more min in the case of *kakusei*<sup>25,46</sup> and 30-60 min in  
3515 the case of *Hr38*<sup>31</sup> and *Egr1*<sup>30</sup>). The frozen bee head was dissected on dry ice under a  
3516 microscope. First, the antennae were removed and a window was cut in the upper part of the  
3517 head capsule, removing the cuticle between the compound eyes and the ocelli. Second, the  
3518 glands and tracheae around the brain were removed. Third, the retinas of the compound eyes  
3519 were also removed.

3520 The frozen brain was cut in three main parts for IEG analyses (Fig. 4A): the optic lobes  
3521 (OL), the upper part of the mushroom bodies (the mushroom-body calyces, MB Ca) and the  
3522 remaining central brain (CB), which included mainly the central complex (CC), the  
3523 subesophageal zone (SEZ) and the peduncula of the mushroom-bodies ( $\alpha$  and  $\beta$  lobes). Samples  
3524 were stored at -80 °C before RNA extraction. During the dissection process, one of these three  
3525 regions was lost in 4 *non-learners* brains. As only bees for which all regions were available were  
3526 kept in the analyses, the sample sizes of the *non-learners* differ between the behavioral (n=18)  
3527 and the molecular analyses (n=14).

3528

### 3529 **RNA extraction and reverse transcription**

3530 The RNAs from the three sections mentioned above (OL, MB Ca and CB) were extracted and  
3531 purified using the RNeasy Micro Kit (Qiagen). The final RNA concentration obtained was  
3532 measured by spectrophotometry (NanoDrop™ One, Thermo Scientific). A volume of 10  $\mu$ l

3533 containing 100 ng of the RNA obtained was used for reverse transcription following the  
3534 procedure recommended in the Maxima H Minus First Strand cDNA Synthesis kit  
3535 (Thermoscientific, 0.25  $\mu$ l of random hexamer primer, 1  $\mu$ l of 10 mM dNTP mix, 3.75  $\mu$ l of  
3536 nuclease free H<sub>2</sub>O, 4  $\mu$ l 5X RT Buffer and 1  $\mu$ l Maxima H Minus Enzyme Mix).

3537

### 3538 **Quantitative Polymerase Chain Reaction (RT-qPCR)**

3539 All the primers used for target and reference genes generated amplification products of  
3540 approximately 150 pb. The efficiencies of all reactions with the different primers used were  
3541 between 95 and 110 % (Table 1). Their specificity was verified by analyzing melting curves of  
3542 the qRT-PCR products (see Supplementary Fig. 2). Two reference genes (*Efl $\alpha$*  and *Actin*) were  
3543 used for normalization.

3544 Expression was quantified using a SYBR Green real-time PCR method. Real-time PCR  
3545 were carried out in 384-Well PCR Plates (Bio-Rad) cover with Microseal 'B' PCR Plate Sealing  
3546 Film (Bio-Rad). The PCR reactions were performed using the SsoAdvanced<sup>TM</sup> Universal  
3547 SYBR<sup>®</sup> Green Supermix (Bio-Rad) in a final volume of 10  $\mu$ l containing 5  $\mu$ l of 2X  
3548 SsoAdvanced<sup>TM</sup> Universal SYBR<sup>®</sup> Green Supermix, 2  $\mu$ l of cDNA template (1:3 dilution  
3549 from the reverse transcription reaction), 0.5  $\mu$ l of 10  $\mu$ mol of each primer and 2  $\mu$ l of ultrapure  
3550 water. The reaction conditions were as follows: 95 °C for 30 s followed by 40 cycles of 95 °C  
3551 for 10 s, 55 °C for 30 s and a final step at 95 °C for 10 s followed by a melt curve from 55 °C  
3552 to 95 °C with 0.5 °C per second. The reaction was performed in a CFX384 Touch Real-Time  
3553 PCR Detection System (Bio-Rad) and analyzed with the software Bio-Rad CFX Manager.

3554 Each sample was run in triplicates. If the triplicates showed too much variability (SD >  
3555 0.3), the furthest triplicate was discarded. If the two remaining triplicates still showed too much  
3556 variability (SD > 0.3) the sample was discarded. The samples were subjected to a relative  
3557 quantification and normalization. First for each sample and for each reference gene per brain

3558 region, the relative quantity ( $Q_r$ ) was computed using the difference between the mean Ct value  
3559 of each sample and the highest mean Ct value ( $\Delta Ct$ ), using the following formula:  $Q_r = (1+E)^{\Delta Ct}$   
3560 (with E= efficiency of the reaction). Then a normalization factor for each sample was obtained  
3561 computing the geometric mean of the relative quantities obtained for the reference genes in the  
3562 corresponding samples ( $\Delta\Delta Ct$ ).

3563

## 3564 **Data analysis and statistics**

### 3565 *Behavioral data*

3566 The first choice of the bees was recorded during the conditioning trials and the non-reinforced  
3567 test. In this way, we established for each trial and test the percentages of bees choosing first  
3568 each of the stimuli displayed or not choosing a stimulus ( $\pm$  95% confidence interval).

3569 Test percentages were analyzed within groups by means of a generalized linear mixed  
3570 model (GLMM) for binomial family in which the individual identity (Bee) was considered as  
3571 a random factor (individual effect) while the choice category (CS+, CS-, NC) was fitted as a  
3572 fixed effect; z values with corresponding degrees of freedom are reported throughout for this  
3573 kind of analysis.

3574 For each acquisition trial, we recorded motor variables such as the total distance walked,  
3575 the walking speed, and the tortuosity of the trajectories<sup>91</sup>. Tortuosity was calculated as the ratio  
3576 between the total distance walked and the distance between the first and the last point of the  
3577 trajectory connected by an imaginary straight line. When the ratio was 1, or close to 1,  
3578 trajectories were straightforward while higher values corresponded to sinuous trajectories<sup>91</sup>.  
3579 The analysis of these continuous variables was done using a linear mixed model (lmer function)  
3580 in which the individual identity (*Bee ID*) was a random factor and the experimental condition  
3581 (*Condition*) and trial number (*Trial*) were fixed factors<sup>91</sup>. Statistical analyses were performed  
3582 using with R 3.5.1<sup>92</sup>. The package lme4 was used for GLMMs and LMMs.

3583 *Gene expression data*

3584 Statistical differences in gene expression were assessed for reference genes to check for stability  
3585 and for target genes within a given brain region using One-Factor ANOVA for independent  
3586 groups in the case of multiple comparisons or two-sample t test in the case of dual comparisons.  
3587 Post hoc comparisons between groups were performed by means of a Tukey test following  
3588 ANOVA. No cross-comparisons between brain regions or genes were performed due to within-  
3589 area normalization procedures. Statistical analyses were done either with R 3.5.1 software<sup>92</sup> or  
3590 with Statistica 13 Software (TIBCO® Data Science).

3591

3592

### 3593 **REPORTING SUMMARY**

3594 Further information on research design is available in the Nature Research Reporting Summary  
3595 linked to this article.

3596

### 3597 **DATA AND CODE AVAILABILITY**

3598 The datasets generated during this study are available at figshare.com with the following  
3599 accession ID: <https://figshare.com/s/1e868800d08a17dc300e>

3600

### 3601 **ACKNOWLEDGMENTS**

3602 We thank three anonymous reviewers for constructive criticisms and Shiori Iino and Takeo  
3603 Kubo for providing useful information on the timing of IEG expression. We also thank  
3604 Benjamin H. Paffhausen, Marco Paoli and Dorian Champelovier for valuable discussions. This  
3605 work was supported by an ERC Advanced Grant ('Cognibrains') to M.G, who also thanks the  
3606 Institut Universitaire de France (IUF), the CNRS and the University Paul Sabatier for support.

3607

3608 **CONTRIBUTIONS**

3609 GL performed the behavioral experiments. HG dissected and sectioned the brains of the bees  
 3610 trained in the VR setup and performed all the molecular analyses. Behavioral experiments were  
 3611 supervised by AB, AAW and MG. Molecular experiments were supervised by IM and MG  
 3612 Statistical analyses on behavioral data were performed by GL and MG. Statistical analyses on  
 3613 gene-expression data were performed by HG and MG. The manuscript was written by MG who  
 3614 also obtained the funding. All authors reviewed and approved the final version of the  
 3615 manuscript.

3616

3617 **ETHICS DECLARATIONS**3618 **Competing interests**

3619 The authors declare no competing interests.

3620

3621

3622 **REFERENCES**

- 3623 1 Giurfa, M. Cognition with few neurons: higher-order learning in insects. *Trends in*  
 3624 *neurosciences* **36**, 285-294 (2013).
- 3625 2 Heisenberg, M. Mushroom body memoir: from maps to models. *Nat Rev Neurosci* **4**, 266-275  
 3626 (2003).
- 3627 3 Cognigni, P., Felsenberg, J. & Waddell, S. Do the right thing: neural network mechanisms of  
 3628 memory formation, expression and update in *Drosophila*. *Current opinion in neurobiology* **49**,  
 3629 51-58 (2018).
- 3630 4 Benjamin, P. R., Kemenes, G. & Kemenes, I. Non-synaptic neuronal mechanisms of learning  
 3631 and memory in gastropod molluscs. *Frontiers in bioscience : a journal and virtual library* **13**,  
 3632 4051-4057 (2008).
- 3633 5 Giurfa, M. Behavioral and neural analysis of associative learning in the honeybee: a taste  
 3634 from the magic well. *J Comp Physiol A* **193**, 801-824 (2007).
- 3635 6 Kandel, E. R. The molecular biology of memory storage: a dialogue between genes and  
 3636 synapses. *Science (New York, N.Y.)* **294**, 1030-1038 (2001).
- 3637 7 Menzel, R. Memory dynamics in the honeybee. *J Comp Physiol A* **185**, 323-340 (1999).
- 3638 8 Menzel, R. The honeybee as a model for understanding the basis of cognition. *Nature Rev*  
 3639 *Neurosci* **13**, 758-768 (2012).

- 3640 9 Giurfa, M. & Sandoz, J. C. Invertebrate learning and memory: fifty years of olfactory  
3641 conditioning of the proboscis extension response in honeybees. *Learning & memory (Cold*  
3642 *Spring Harbor, N.Y.)* **19**, 54-66 (2012).
- 3643 10 Avargues-Weber, A., Deisig, N. & Giurfa, M. Visual cognition in social insects. *Annual review*  
3644 *of entomology* **56**, 423-443 (2011).
- 3645 11 Avargues-Weber, A., Mota, T. & Giurfa, M. New vistas on honey bee vision. *Apidologie* **43**,  
3646 244-268 (2012).
- 3647 12 Buatois, A. *et al.* Associative visual learning by tethered bees in a controlled visual  
3648 environment. *Sci Reports* **7**, 127903 (2017).
- 3649 13 Schultheiss, P., Buatois, A., Avarguès-Weber, A. & Giurfa, M. Using virtual reality to study  
3650 visual performances of honeybees. *Curr Opin Insect Sci* **24**, 43–50 (2017).
- 3651 14 Buatois, A., Flumian, C., Schultheiss, P., Avargues-Weber, A. & Giurfa, M. Transfer of visual  
3652 learning between a virtual and a real environment in honey bees: the role of active vision.  
3653 *Front Behav Neurosci* **12**, 139 (2018).
- 3654 15 Rusch, C., Roth, E., Vinauger, C. & Riffell, J. A. Honeybees in a virtual reality environment  
3655 learn unique combinations of colour and shape. *J Exp Biol* **220**, 3478-3487 (2017).
- 3656 16 Zwaka, H. *et al.* Learning and its neural correlates in a virtual environment for honeybees.  
3657 *Front Behav Neurosci* **12**, 279 (2018).
- 3658 17 Rusch, C., Alonso San Alberto, D. & Riffell, J. A. Visuo-motor feedback modulates neural  
3659 activities in the medulla of the honeybee, *Apis mellifera*. *J Neurosci* **41**, 3192-3203 (2021).
- 3660 18 Buatois, A., Laroche, L., Lafon, G., Avargues-Weber, A. & Giurfa, M. Higher-order  
3661 discrimination learning by honeybees in a virtual environment. *The European journal of*  
3662 *neuroscience* **51**, 681-694 (2020).
- 3663 19 Clayton, D. F. The genomic action potential. *Neurobiol Learn Mem* **74**, 185-216 (2000).
- 3664 20 Bahrami, S. & Drablos, F. Gene regulation in the immediate-early response process. *Adv Biol*  
3665 *Regul* **62**, 37-49 (2016).
- 3666 21 Minatohara, K., Akiyoshi, M. & Okuno, H. Role of immediate-early genes in synaptic plasticity  
3667 and neuronal ensembles underlying the memory trace. *Frontiers in molecular neuroscience* **8**,  
3668 78 (2015).
- 3669 22 Gallo, F. T., Katche, C., Morici, J. F., Medina, J. H. & Weisstaub, N. V. Immediate early genes,  
3670 memory and psychiatric disorders: focus on *c-Fos*, *Egr1* and *Arc*. *Front Behav Neurosci* **12**, 79  
3671 (2018).
- 3672 23 He, Q., Wang, J. & Hu, H. Illuminating the activated brain: emerging activity-dependent tools  
3673 to capture and control functional neural circuits. *Neuroscience bulletin* **35**, 369-377 (2019).
- 3674 24 Sommerlandt, F. M. J., Brockmann, A., Roessler, W. & Spaethe, J. Immediate early genes in  
3675 social insects: a tool to identify brain regions involved in complex behaviors and molecular  
3676 processes underlying neuroplasticity. *Cell Mol Life Sci* **76**, 637-651 (2019).
- 3677 25 Kiya, T., Kunieda, T. & Kubo, T. Increased neural activity of a mushroom body neuron subtype  
3678 in the brains of forager honeybees. *PLoS One* **2**, e371 (2007).
- 3679 26 Kiya, T. & Kubo, T. Dance type and flight parameters are associated with different mushroom  
3680 body neural activities in worker honeybee brains. *PLoS One* **6**, e19301 (2011).
- 3681 27 Kiya, T., Kunieda, T. & Kubo, T. Inducible- and constitutive-type transcript variants of kakusei ,  
3682 a novel non-coding immediate early gene, in the honeybee brain. *Insect Mol Biol* **17**, 531-536  
3683 (2008).
- 3684 28 Fujita, N. *et al.* Visualization of neural activity in insect brains using a conserved immediate  
3685 early gene, Hr38. *Curr Biol* **23**, 2063-2070 (2013).
- 3686 29 Singh, A. S., Shah, A. & Brockmann, A. Honey bee foraging induces upregulation of early  
3687 growth response protein 1, hormone receptor 38 and candidate downstream genes of the  
3688 ecdysteroid signalling pathway. *Insect Mol Biol* **27**, 90-98 (2018).
- 3689 30 Iino, S. *et al.* Neural activity mapping of bumble bee (*Bombus ignitus*) brains during foraging  
3690 flight using immediate early genes. *Sci Rep* **10**, 7887 (2020).

- 3691 31 Ugajin, A. *et al.* Identification and initial characterization of novel neural immediate early  
3692 genes possibly differentially contributing to foraging-related learning and memory processes  
3693 in the honeybee. *Insect Mol Biol* **27**, 154-165 (2018).
- 3694 32 Lutz, C. C. & Robinson, G. E. Activity-dependent gene expression in honey bee mushroom  
3695 bodies in response to orientation flight. *J Exp Biol* **216**, 2031-2038 (2013).
- 3696 33 Shah, A., Jain, R. & Brockmann, A. Egr-1: A candidate transcription factor involved in  
3697 molecular processes underlying time-memory. *Frontiers in Psychology* **9** (2018).
- 3698 34 Giurfa, M. Conditioning procedure and color discrimination in the honeybee *Apis mellifera*.  
3699 *Naturwissenschaften* **91**, 228-231 (2004).
- 3700 35 Dyer, A. G. & Chittka, L. Fine colour discrimination requires differential conditioning in  
3701 bumblebees. *Naturwissenschaften* **91**, 224-227 (2004).
- 3702 36 Avarguès-Weber, A. & Giurfa, M. Cognitive components of color vision in honey bees: how  
3703 conditioning variables modulate color learning and discrimination. *J Comp Physiol A* **200**, 449-  
3704 461 (2014).
- 3705 37 Avarguès-Weber, A., de Brito Sanchez, M. G., Giurfa, M. & Dyer, A. G. Aversive reinforcement  
3706 improves visual discrimination learning in free-flying honeybees. *PLoS One* **5**, e15370 (2010).
- 3707 38 Menzel, R. The insect mushroom body, an experience-dependent recoding device. *Journal of*  
3708 *physiology, Paris* **108**, 84-95 (2014).
- 3709 39 de Brito Sanchez, M. G., Serre, M., Avarguès-Weber, A., Dyer, A. G. & Giurfa, M. Learning  
3710 context modulates aversive taste strength in honey bees. *J Exp Biol* **218**, 949-959 (2015).
- 3711 40 Aguiar, J., Roselino, A. C., Sazima, M. & Giurfa, M. Can honey bees discriminate between  
3712 floral-fragrance isomers? *J Exp Biol* **221** (2018).
- 3713 41 Dyer, A. G. & Chittka, L. Bumblebees (*Bombus terrestris*) sacrifice foraging speed to solve  
3714 difficult colour discrimination tasks. *J Comp Physiol A* **190**, 759-763 (2004).
- 3715 42 Ings, T. C. & Chittka, L. Speed-accuracy tradeoffs and false alarms in bee responses to cryptic  
3716 predators. *Curr Biol* **18**, 1520-1524 (2008).
- 3717 43 Burns, J. G. & Dyer, A. G. Diversity of speed-accuracy strategies benefits social insects. *Curr*  
3718 *Biol* **18**, R953-R954 (2008).
- 3719 44 Marchal, P. *et al.* Inhibitory learning of phototaxis by honeybees in a passive-avoidance task.  
3720 *Learning & memory (Cold Spring Harbor, N.Y.)* **26**, 412-423 (2019).
- 3721 45 Kiya, T. & Kubo, T. Analysis of GABAergic and non-GABAergic neuron activity in the optic  
3722 lobes of the forager and re-orienting worker honeybee (*Apis mellifera* L.). *PLoS One* **5**, e8833  
3723 (2010).
- 3724 46 Ugajin, A. *et al.* Detection of neural activity in the brains of Japanese honeybee workers  
3725 during the formation of a "hot defensive bee ball". *PLoS One* **7**, e32902 (2012).
- 3726 47 Devaud, J. M. *et al.* Neural substrate for higher-order learning in an insect: Mushroom bodies  
3727 are necessary for configural discriminations. *Proc Natl Acad Sci U S A* **112**, E5854-5862  
3728 (2015).
- 3729 48 Guven-Ozkan, T. & Davis, R. L. Functional neuroanatomy of *Drosophila* olfactory memory  
3730 formation. *Learning & memory (Cold Spring Harbor, N.Y.)* **21**, 519-526 (2014).
- 3731 49 Paulk, A. C., Phillips-Portillo, J., Dacks, A. M., Fellous, J. M. & Gronenberg, W. The processing  
3732 of color, motion, and stimulus timing are anatomically segregated in the bumblebee brain. *J*  
3733 *Neurosci* **28**, 6319-6332 (2008).
- 3734 50 Paulk, A. C., Dacks, A. M., Phillips-Portillo, J., Fellous, J. M. & Gronenberg, W. Visual  
3735 processing in the central bee brain. *J Neurosci* **29**, 9987-9999 (2009).
- 3736 51 Menzel, R. & Backhaus, W. in *Vision and Visual Dysfunction. The Perception of Colour.* (ed P.  
3737 Gouras) 262-288 (MacMillan Press, 1991).
- 3738 52 Mota, T., Yamagata, N., Giurfa, M., Gronenberg, W. & Sandoz, J. C. Neural organization and  
3739 visual processing in the anterior optic tubercle of the honeybee brain. *J Neurosci* **31**, 11443-  
3740 11456 (2011).
- 3741 53 Paulk, A. C., Dacks, A. M. & Gronenberg, W. Color processing in the medulla of the  
3742 bumblebee (Apidae: *Bombus impatiens*). *J Comp Neurol* **513**, 441-456 (2009).

- 3743 54 Paulk, A. C. & Gronenberg, W. Higher order visual input to the mushroom bodies in the bee,  
3744 *Bombus impatiens*. *Arthropod Struct Dev* **37**, 443-458 (2008).
- 3745 55 Dyer, A. G., Paulk, A. C. & Reser, D. H. Colour processing in complex environments: insights  
3746 from the visual system of bees. *Proc Biol Sci* **278**, 952-959 (2011).
- 3747 56 Kirschner, S. *et al.* Dual olfactory pathway in the honeybee, *Apis mellifera*. *J Comp Neurol*  
3748 **499**, 933-952 (2006).
- 3749 57 Ehmer, B. & Gronenberg, W. Segregation of visual input to the mushroom bodies in the  
3750 honeybee (*Apis mellifera*). *J Comp Neurol* **451**, 362-373 (2002).
- 3751 58 Kirkerud, N. H., Schlegel, U. & Giovanni Galizia, C. Aversive learning of colored lights in  
3752 walking honeybees. *Front Behav Neurosci* **11**, 94 (2017).
- 3753 59 Plath, J. A. *et al.* Different roles for honey bee mushroom bodies and central complex in  
3754 visual learning of colored lights in an aversive conditioning assay. *Front Behav Neurosci* **11**, 98  
3755 (2017).
- 3756 60 Vergoz, V., Roussel, E., Sandoz, J. C. & Giurfa, M. Aversive learning in honeybees revealed by  
3757 the olfactory conditioning of the sting extension reflex. *PLoS One* **2**, e288 (2007).
- 3758 61 Tedjakumala, S. R., Aimable, M. & Giurfa, M. Pharmacological modulation of aversive  
3759 responsiveness in honey bees. *Front Behav Neurosci* **7** (2014).
- 3760 62 Wolf, R. *et al.* *Drosophila* mushroom bodies are dispensable for visual, tactile, and motor  
3761 learning. *Learning & memory (Cold Spring Harbor, N.Y.)* **5**, 166-178 (1998).
- 3762 63 Heisenberg, M., Borst, A., Wagner, S. & Byers, D. *Drosophila* mushroom body mutants are  
3763 deficient in olfactory learning. *J Neurogenet* **2**, 1-30 (1985).
- 3764 64 Ofstad, T. A., Zuker, C. S. & Reiser, M. B. Visual place learning in *Drosophila melanogaster*.  
3765 *Nature* **474**, 204-U240 (2011).
- 3766 65 Vogt, K. *et al.* Shared mushroom body circuits underlie visual and olfactory memories in  
3767 *Drosophila*. *Elife* **3**, e02395 (2014).
- 3768 66 Szyszka, P., Ditzen, M., Galkin, A., Galizia, C. G. & Menzel, R. Sparsening and temporal  
3769 sharpening of olfactory representations in the honeybee mushroom bodies. *J Neurophysiol*  
3770 **94**, 3303-3313 (2005).
- 3771 67 Perez-Orive, J. *et al.* Oscillations and sparsening of odor representations in the mushroom  
3772 body. *Science* **297**, 359-365 (2002).
- 3773 68 Laurent, G. J. *et al.* Odor encoding as an active, dynamical process: experiments,  
3774 computation, and theory. *Annu Rev Neurosci* **24**, 263-297 (2001).
- 3775 69 Lin, A. C., Bygrave, A. M., de Calignon, A., Lee, T. & Miesenbock, G. Sparse, decorrelated odor  
3776 coding in the mushroom body enhances learned odor discrimination. *Nat Neurosci* **17**, 559-  
3777 568 (2014).
- 3778 70 Froese, A., Szyszka, P. & Menzel, R. Effect of GABAergic inhibition on odorant concentration  
3779 coding in mushroom body intrinsic neurons of the honeybee. *J Comp Physiol A* **200**, 183-195  
3780 (2014).
- 3781 71 Papadopoulou, M., Cassenaer, S., Nowotny, T. & Laurent, G. Normalization for sparse  
3782 encoding of odors by a wide-field interneuron. *Science* **332**, 721-725 (2011).
- 3783 72 Rybak, J. & Menzel, R. Anatomy of the mushroom bodies in the honey bee brain: The  
3784 neuronal connections of the alpha-lobe. *J Comp Neurobiol* **334**, 444-465 (1993).
- 3785 73 Zwaka, H., Bartels, R., Grunewald, B. & Menzel, R. Neural Organization of A3 Mushroom Body  
3786 Extrinsic Neurons in the Honeybee Brain. *Front Neuroanat* **12**, 57 (2018).
- 3787 74 Suenami, S., Oya, S., Kohno, H. & Kubo, T. Kenyon cell subtypes/populations in the honeybee  
3788 mushroom bodies: possible function based on their gene expression profiles, differentiation,  
3789 possible evolution, and application of genome editing. *Front Psychol* **9** (2018).
- 3790 75 Kaneko, K. *et al.* Novel middle-type Kenyon cells in the honeybee brain revealed by area-  
3791 preferential gene expression analysis. *PLoS One* **8**, e71732 (2013).
- 3792 76 Strausfeld, N. J. Organization of the honey bee mushroom body: representation of the calyx  
3793 within the vertical and gamma lobes. *J Comp Neurol* **450**, 4-33 (2002).

- 3794 77 Shah, A., Jain, R. & Brockmann, A. Egr-1: A Candidate transcription factor involved in  
3795 molecular processes underlying time-memory. *Front Psychol* **9** (2018).
- 3796 78 Ugajin, A., Kunieda, T. & Kubo, T. Identification and characterization of an Egr ortholog as a  
3797 neural immediate early gene in the European honeybee (*Apis mellifera* L.). *FEBS Letters* **587**,  
3798 3224-3230 (2013).
- 3799 79 Gehring, K. B., Heufelder, K., Kersting, I. & Eisenhardt, D. Abundance of phosphorylated *Apis*  
3800 *mellifera* CREB in the honeybee's mushroom body inner compact cells varies with age. *J*  
3801 *Comp Neurol* **524**, 1165-1180 (2016).
- 3802 80 Silva, A. J., Kogan, J. H., Frankland, P. W. & Kida, S. CREB and memory. *Annual review of*  
3803 *neuroscience* **21**, 127-148 (1998).
- 3804 81 Kandel, E. R. The molecular biology of memory: cAMP, PKA, CRE, CREB-1, CREB-2, and CPEB.  
3805 *Mol Brain* **5**, 14 (2012).
- 3806 82 Yin, J. C. P. & Tully, T. CREB and the formation of long-term memory. *Current opinion in*  
3807 *neurobiology* **6**, 264-268 (1996).
- 3808 83 Alberini, C. M. Transcription factors in long-term memory and synaptic plasticity.  
3809 *Physiological reviews* **89**, 121-145 (2009).
- 3810 84 Wüstenberg, D., Gerber, B. & Menzel, R. Long- but not medium-term retention of olfactory  
3811 memory in honeybees is impaired by actinomycin D and anisomycin. *The European journal of*  
3812 *neuroscience* **10**, 261-261 (1998).
- 3813 85 Villar, M. E., Marchal, P., Viola, H. & Giurfa, M. Redefining single-trial memories in the honey  
3814 bee. *Cell Reports* **30**, 2603-2613 (2020).
- 3815 86 Avarguès-Weber, A. & Giurfa, M. Conceptual learning by miniature brains. *Proc Biol Sci*  
3816 (2013).
- 3817 87 Giurfa, M. An Insect's Sense of Number. *Trends Cogn Sci* **23**, 720-722 (2019).
- 3818 88 Giurfa, M. Learning of sameness/difference relationships by honey bees: performance,  
3819 strategies and ecological context. *Curr Opin Behav Sci* **37**, 1-6 (2021).
- 3820 89 de Brito Sanchez, M. G., Serre, M., Avargues-Weber, A., Dyer, A. G. & Giurfa, M. Learning  
3821 context modulates aversive taste strength in honey bees. *J Exp Biol* **218**, 949-959 (2015).
- 3822 90 Bestea, L. *et al.* Peripheral taste detection in honey bees: what do taste receptors respond  
3823 to? *The European journal of neuroscience* (2021).
- 3824 91 Lafon, G., Howard, S. R., Paffhausen, B. H., Avarguès-Weber, A. & Giurfa, M. Motion cues  
3825 from the background influence associative color learning of honey bees in a virtual-reality  
3826 scenario. *Sci Rep* **11**, 21127 (2021).
- 3827 92 R Development Core Team. *R: A Language and Environment for Statistical Computing*. (The R  
3828 Foundation for Statistical Computing, 2016).
- 3829
- 3830

3831

3832

## Chapter 3

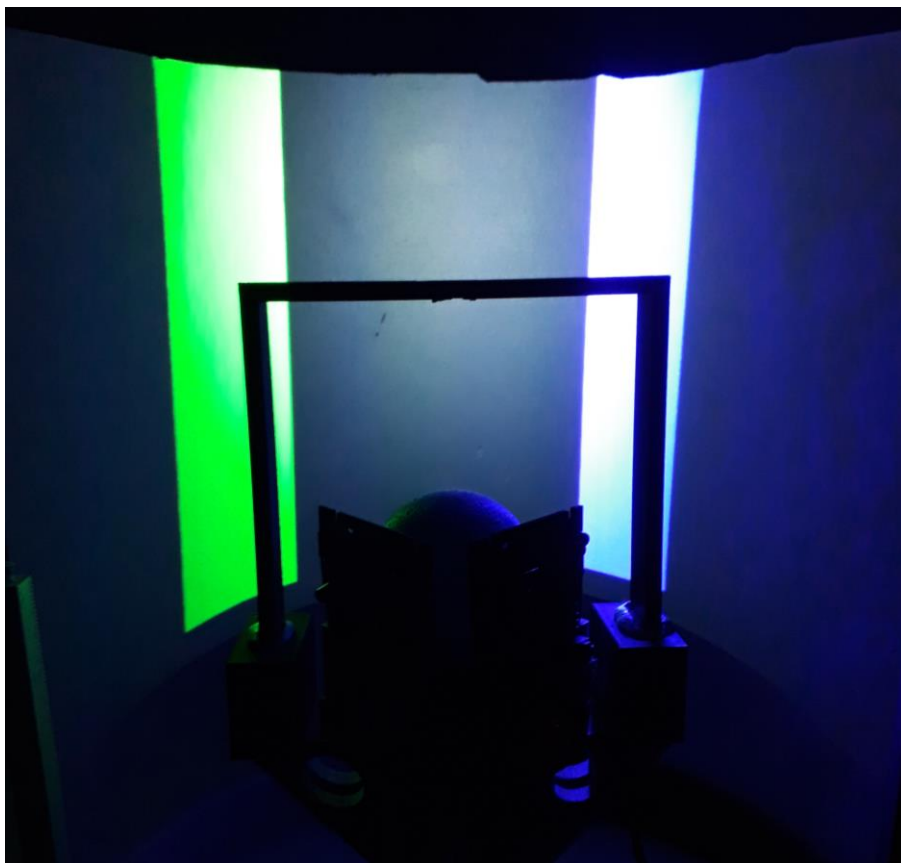
3833 **The neural signature of visual learning under restrictive virtual-reality**3834 **conditions**

3835

3836

3837



## The Neural Signature of Visual Learning Under Restrictive Virtual-Reality Conditions

Gregory Lafon<sup>1†</sup>, Haiyang Geng<sup>1,2†</sup>, Aurore Avarguès-Weber<sup>1</sup>, Alexis Buatois<sup>1†§</sup>, Isabelle Massou<sup>1§</sup> and Martin Giurfa<sup>1,2,3\*§</sup>

<sup>1</sup> Research Center on Animal Cognition, Center for Integrative Biology, CNRS, University of Toulouse, Toulouse, France, <sup>2</sup> College of Animal Sciences (College of Bee Science), Fujian Agriculture and Forestry University, Fuzhou, China, <sup>3</sup> Institut Universitaire de France, Paris, France

OPEN ACCESS

3838

3839 In the second chapter, we found that visual learning under 3D VR conditions led to an up-  
3840 regulation of *Egr1* in the calyces of the mushroom bodies. We thus asked a different question,  
3841 namely whether the constraints of the VR environmental impact on neural activation in a color  
3842 discrimination task. Specifically, we asked if learning the same color discrimination as in the  
3843 previous chapter, but this time in a 2D VR, which sets higher movement constraints, results in  
3844 similar IEG expression patterns as those detected in the 3D environment. Surprisingly, the  
3845 comparison between non-learners and learners revealed a completely different pattern of  
3846 activation from the one found in the second chapter. Here, *Egr1* was downregulated in the optic  
3847 lobes, while *Hr38* and *kakusei* were coincidentally downregulated in the mushroom body calyces.  
3848 In this chapter, we present these results and offer some possible explanations as to why 2D  
3849 conditioning leads to a different pattern of IEG expression. In particular, we interpret this  
3850 downregulation as a reflect of a higher neural inhibition in the 2D VR discrimination.

3851

3852 **The neural signature of visual learning under restrictive virtual-**  
3853 **reality conditions**

3854

3855 **Gregory Lafon<sup>1\*</sup>, Haiyang Geng<sup>\*1,2</sup>, Aurore Avarguès-Weber<sup>1</sup>, Alexis**  
3856 **Buatois<sup>1,¥,§</sup>, Isabelle Massou<sup>1,§</sup>, Martin Giurfa<sup>1,2,3§</sup>**

3857

3858 <sup>1</sup> Research Centre on Animal Cognition, Center for Integrative Biology, CNRS, University of Toulouse,  
3859 118 route de Narbonne, F-31062 Toulouse cedex 09, France.

3860 <sup>2</sup> College of Animal Sciences (College of Bee Science), Fujian Agriculture and Forestry University,  
3861 Fuzhou 350002, China.

3862 <sup>3</sup> Institut Universitaire de France, Paris, France (IUF).

3863

3864

3865 \* Equal contribution

3866 § Senior authorship shared

3867 ¥ Present address: Institute of Neuroscience and Physiology, Department of Neurochemistry and  
3868 Psychiatry, University of Gothenburg, Su Sahlgrenska, 41345 Göteborg, Sweden.

3869

3870 **Corresponding author:** Dr. Martin Giurfa

3871 Research Centre on Animal Cognition, CNRS – UPS, 31062 Toulouse cedex 9, France

3872 [martin.giurfa@univ-tlse3.fr](mailto:martin.giurfa@univ-tlse3.fr)

3873

3874 **Subject Areas:** Behavior, Neuroscience

3875

3876

**3877 Abstract**

3878 Honey bees are reputed for their remarkable visual learning and navigation capabilities. These  
3879 capacities can be studied in virtual reality (VR) environments, which allow studying  
3880 performances of tethered animals in stationary flight or walk under full control of the sensory  
3881 environment. Here we used a 2D VR setup in which a tethered bee walking stationary under  
3882 restrictive closed-loop conditions learned to discriminate vertical rectangles differing in color  
3883 and reinforcing outcome. Closed-loop conditions restricted stimulus control to lateral  
3884 displacements. Consistently with prior VR analyses, bees learned to discriminate the trained  
3885 stimuli. Ex vivo analyses on the brains of learners and non-learners showed that successful  
3886 learning led to a downregulation of three immediate early genes in the main regions of the visual  
3887 circuit, the optic lobes (OLs) and the calyces of the mushroom bodies (MBs). While *Egr1* was  
3888 downregulated in the OLs, *Hr38* and *kakusei* were coincidentally downregulated in the calyces  
3889 of the MBs. Our work thus reveals that color discrimination learning induced a neural signature  
3890 distributed along the sequential pathway of color processing that is consistent with an inhibitory  
3891 trace. This trace may relate to the motor patterns required to solve the discrimination task, which  
3892 are different from those underlying pathfinding in 3D VR scenarios allowing for navigation and  
3893 exploratory learning and which lead to IEG upregulation.

3894

**3895 Keywords**

3896 Vision – Visual Learning – Virtual Reality – Honey Bee Brain – Immediate Early Genes –  
3897 Mushroom Bodies – Optic Lobes

3898

## 3899 Introduction

3900 Learning relies on changes in neural activity and/or connectivity in the nervous system, which  
3901 underlie the acquisition of new, durable information based on individual experience.  
3902 Invertebrate models have proved to be extremely influential to characterize learning and  
3903 memory at multiple levels, not only because they allow determining where and when such  
3904 changes occur in the nervous system<sup>1-7</sup> but also because their behavioral performances can be  
3905 studied in standardized laboratory protocols that allow full control over the sensory variables  
3906 that animals should learn and memorize. A paradigmatic example is provided by the honey bee  
3907 *Apis mellifera*, where the study of olfactory learning and memory experienced significant  
3908 progresses thanks to the availability of a Pavlovian conditioning protocol that offers the  
3909 possibility of acquiring consistent behavioral data coupled with the simultaneous use of  
3910 invasive methods to record neural activity<sup>5, 8-10</sup>. In this protocol, termed the olfactory  
3911 conditioning of the proboscis extension reflex (PER), harnessed bees learn to associate an  
3912 odorant with a reward of sucrose solution<sup>10, 11</sup>. The immobility imposed to the trained bees and  
3913 the Pavlovian nature of the association learned (the odorant acts as the conditioned stimulus  
3914 and the sucrose reward as the unconditioned stimulus) allows a full control over the stimulations  
3915 provided and thus a fine characterization of behavioral changes due to learning and memory.

3916 In the case of visual learning by honey bees, this possibility is reduced as performances  
3917 are mostly studied in free-flying foragers<sup>5, 12</sup> under semi-natural conditions. Yet, virtual-reality  
3918 (VR) environments have been recently developed to overcome this limitation<sup>13</sup> as they provide  
3919 not only a full control over the visual surrounding of an experimental subject, be it tethered or  
3920 not, but also the delivery of physically impossible ambiguous stimuli, which give conflicting  
3921 visual information<sup>14</sup>. In one type of VR that we developed in the last years, a tethered bee walks  
3922 stationary on a treadmill while being exposed to a controlled visual environment displayed by  
3923 a video projector. Bees can then be trained with virtual targets that are paired with gustatory

3924 reward or punishment<sup>13, 15-19</sup>. To create an immersive environment, closed-loop visual  
3925 conditions are used in which the variations of the visual panorama are determined by the  
3926 walking movements of the bee on the treadmill. Under these conditions, bees learn and  
3927 memorize simple<sup>15, 19</sup> and higher-order<sup>20</sup> visual discriminations, which offers the potential for  
3928 mechanistic analyses of visually-oriented performances<sup>17, 18</sup>.

3929         We have used two different types of closed loop situation so far: a restrictive 2D  
3930 situation, in which bees can displace conditioned targets only frontally (i.e. from left to right  
3931 and vice versa)<sup>15, 19, 20</sup>, and a more realistic 3D situation which includes a depth dimension so  
3932 that targets expand upon approach and retract upon distancing<sup>21</sup>. Although bees learn to  
3933 discriminate color stimuli in both conditions, the processes underlying such learning may differ  
3934 given the different conditions imposed to the bees in terms of stimulus control. Indeed, while  
3935 in 3D scenarios movement translates into a displacement and a recognizable change in the  
3936 visual scene, which can then be computed against the available internal information about the  
3937 displacement, 2D scenarios are restricted to the execution of actions that are dependent on  
3938 reinforcement contingency. These two conditions may give rise to different mechanisms of  
3939 information acquisition.

3940         In a recent work, we studied color learning in the 3D scenario and quantified immediate  
3941 early genes (IEGs) in the brain of learners and non-learners to uncover the regions that are  
3942 involved in this discrimination learning<sup>22</sup>. IEGs are efficient markers of neural activity as they  
3943 are transcribed transiently and rapidly in response to specific stimulations inducing neural  
3944 activity without *de novo* protein synthesis<sup>23-25</sup>. Three IEGs were quantified on the basis of  
3945 numerous reports that associated them with foraging and orientation activities<sup>26-30</sup>: *kakusei*, a  
3946 nuclear non-coding RNA<sup>31</sup>, the hormone receptor 38 gene (*Hr38*), a component of the  
3947 ecdysteroid signalling pathway<sup>32</sup>, and the early growth response gene-1 (*Egr1*), which is a  
3948 major mediator and regulator of synaptic plasticity and neuronal activity<sup>33</sup>. We found that color

3949 learning in the 3D VR environment was associated with an *upregulation* of *Egr1* in the calyces  
3950 of the mushroom bodies<sup>22</sup>, a main structure of the insect brain repeatedly associated with the  
3951 storage and retrieval of olfactory memories<sup>2, 9</sup>. No other changes of IEG expression were  
3952 detected in other regions of the brain, thus underlining the relevance of mushroom bodies for  
3953 color learning and retention<sup>22</sup>.

3954         Here we asked if color learning in the more restrictive 2D VR environment induces  
3955 changes in IEG expression, both at the gene level and at the brain region level, similar to those  
3956 detected in the 3D VR system. Asking this question is important to determine if changes in IEG  
3957 expression differ according to the degrees of freedom of the VR system and the distinct motor  
3958 patterns that are engaged in either case. Despite the similarity in behavioral performance (bees  
3959 learn to discriminate colors in both scenarios), we reasoned that the processes underlying  
3960 learning may be different given the restrictive conditions of the 2D VR, which demand a tight  
3961 stimulus control while the 3D VR enables exploration of the virtual environment. We thus  
3962 studied color learning in the 2D VR environment and performed *ex vivo* analyses to map IEG  
3963 expression in brain areas of learners and non-learners, which had the same sensory experience  
3964 and only differed in terms of learning success.

3965

3966

## 3967 **Results**

### 3968 **Behavioral analyses**

3969 Honey bee foragers from a hive located in our apiary were captured at an artificial feeder to  
3970 which they were previously trained. They were enclosed in individual glass vials and brought  
3971 to the laboratory where they were prepared for the VR experiments. A tether was glued on their  
3972 thorax (Fig. 1A,B), which allowed to attach them to a holder to adjust their position on a  
3973 treadmill. The treadmill was a polystyrene ball that was suspended on an air cushion produced

3974 by an air pumping system (see Methods for details). The bee suspended from its tether could  
3975 walk stationary on the treadmill; its movements were recorded by two infrared optic-mouse  
3976 sensors placed on the ball support perpendicular to each other, which allowed to reconstruct the  
3977 trajectories and quantify motor parameters. A semi-cylindrical screen made of semitransparent  
3978 tracing paper was placed in front of the treadmill (i.e. of the walking bee; Fig. 1A). Images were  
3979 projected onto this screen by a video projector placed behind it.

3980 Bees were trained to discriminate a green from a blue vertical bar against a black  
3981 background during ten conditioning trials (Fig. 1C; see Supplementary Fig. 1 for color  
3982 characteristics). Experiments were performed under 2D closed-loop conditions so that the  
3983 movements of the walking bee displaced the bars laterally on the screen to bring them towards  
3984 or away from front of the bee. During training, one of the bars (CS+) was rewarded with 1 M  
3985 sucrose solution while the other bar (CS-) was punished with an aversive 3M NaCl solution<sup>34-</sup>  
3986 <sup>36</sup>. A choice was recorded when the bee moved one rectangle to the center of the screen (i.e.,  
3987 between  $-12.5^\circ$  and  $+12.5^\circ$  of the bee's central axis; see Fig. 1D, right).

3988 We segregated learners and non-learners according to the bees' performance in a  
3989 dedicated unrewarded test at the end of the training. Learners (n=23) were those bees that  
3990 showed successful discrimination in the test (i.e. which chose the CS+). Non-learners (n=17),  
3991 were those bees that did not succeed in the test (i.e. they either chose the CS- or did not make  
3992 a choice). Importantly, these bees have the same sensory experience in terms of exposure to the  
3993 color stimuli and reinforcements as our training procedure froze the CS+ or the CS- stimuli in  
3994 front of the bee during 8 s upon a choice and delivered the reinforcements accordingly. Bees  
3995 that did neither choose the CS+ nor the CS- in at least 5 trials were excluded from the analysis.

3996 Acquisition was significant for learners during conditioning trials (Fig. 2A; CS\**Trial*  
3997 effect:  $\chi^2=47.746$ , *df*:2,  $p<0.0001$ ), thus showing that the categorization made based on test  
3998 performance reflected well learning success. The percentages of bees responding to the CS+

3999 and to the CS- differed significantly along trials (CS+ vs. CS-: CS\*Trial;  $z=6.845$ ,  $p<0.0001$ ).  
4000 Significant differences were also found between the bees responding to the CS- and the non-  
4001 responders (CS- vs NC: CS\*Trial;  $z=3.541$ ,  $p=0.0004$ ) but not between bees responding to the  
4002 CS+ and non-responders (CS+ vs. NC: CS\*Trial;  $z=-1.201$ ,  $p=0.23$ ). Non-learners ( $n=17$ ) did  
4003 also show a significant CS\*Trial effect (Fig. 2B;  $\chi^2=9.8383$ ,  $df=2$ ,  $p=0.007$ ), but this effect was  
4004 introduced by the non-responders. These bees differed significantly along trials both from the  
4005 bees responding to the CS+ (CS+ vs. NC: CS\*Trial;  $z=2.356$ ,  $p=0.019$ ) and from the bees  
4006 responding to the CS- (CS- vs. NC: CS\*Trial;  $z=3.068$ ,  $p=0.002$ ). On the contrary, the  
4007 percentages of bees responding to the CS+ and to the CS- did not vary along trials (CS+ vs.  
4008 CS-: CS\*Trial;  $z=1.437$ ,  $p=0.2$ ), consistently with the absence of learning.

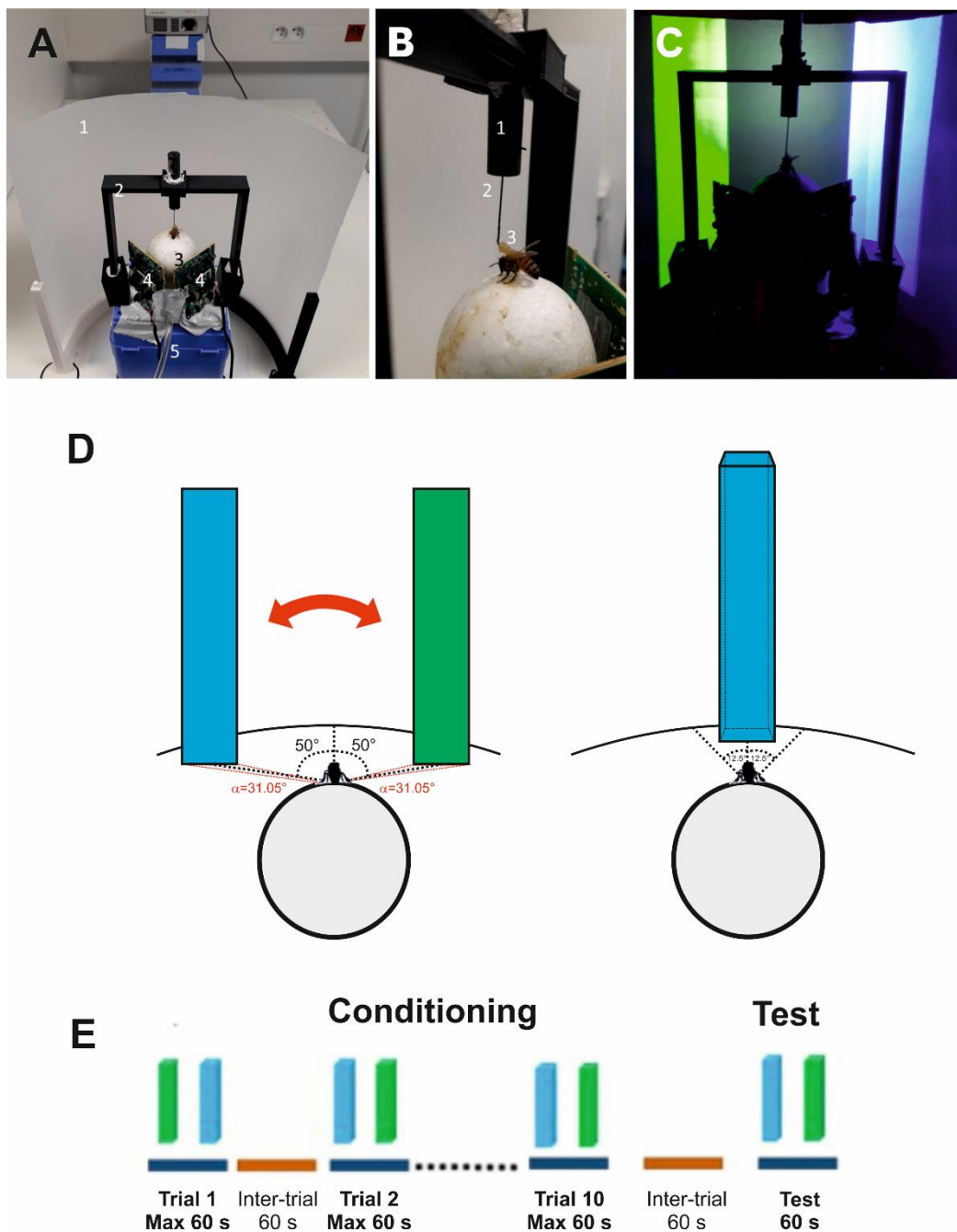

4009

4010 **Figure 1. Experimental setup, choice criterion and conditioning procedure.** A) **Global**  
 4011 **view of the setup.** 1: Semicircular projection screen made of tracing paper. 2: Holding frame  
 4012 to place the tethered bee on the treadmill. 3: The treadmill was a Styrofoam ball positioned  
 4013 within a cylindrical support (not visible) floating on an air cushion. 4: Infrared mouse optic  
 4014 sensors allowing to record the displacement of the ball and to reconstruct the bee's trajectory.  
 4015 5: Air arrival. The video projector displaying images on the screen from behind can be seen on  
 4016 top of the image. B) **The tethering system.** 1: Plastic cylinder held by the holding frame; the  
 4017 cylinder contained a glass cannula into which a steel needle was inserted. 2: The needle was  
 4018 attached to the thorax of the bee. 3: Its curved end was fixed to the thorax by means of melted  
 4019 bee wax. C) **Color discrimination learning in the VR setup.** The bee had to learn to  
 4020 discriminate two vertical bars based on their different color and their association with reward  
 4021 and punishment. Bars were green and blue on a dark background. Color intensities were  
 4022 adjusted to avoid phototactic biases independent of learning. Displacement of the bars was

4023 restricted to the 2D plane in front of the bee. **D) Left: view of the stimuli at the start of a trial**  
4024 **or test.** The green and the blue virtual bars were presented at  $-50^\circ$  and  $+50^\circ$  of the bee's  
4025 longitudinal axis of the bee. Stimuli could be only displaced by the bee from left to right and  
4026 vice versa (double red arrow). The red angles on the virtual surface indicate the visual angle  
4027 subtended by each bar at the bee position ( $\square = 31.05^\circ$ ). **Right: Choice of a bar.** A choice was  
4028 recorded when the bee kept the center of the object between  $-12.5^\circ$  and  $+12.5^\circ$  in front of it for  
4029 1 second. The bar image was then frozen during 8 s and the corresponding reinforcement (US)  
4030 was delivered. **E) Conditioning protocol.** Bees were trained along 10 conditioning trials that  
4031 lasted a maximum of 1 min and that were spaced by 1 min (intertrial interval). After the end of  
4032 conditioning, and following an additional interval of 1 min, bees were tested in extinction  
4033 conditions during 1 min.

4034

4035           Learners and non-learners did not differ in their motor activity during training, thus  
4036 excluding this factor as determinant of possible changes in neural activity. When walking  
4037 speeds and the distances travelled were compared between groups, no significant differences  
4038 were detected (*Distance*: Group;  $\chi^2=1.93$ , df:1,  $p=0.16$ ; *Speed*: Group;  $\chi^2=1.78$ , df:1,  $p=0.18$ ).

4039           In the non-reinforced test, per definition learners (Fig. 2C) chose correctly the CS+  
4040 (100% of the bees) while non-learners (Fig. 2D) did either chose the CS- (35%) or did not  
4041 perform any choice (65%). Learners spent more time fixating the CS+ than the CS- consistently  
4042 with the choice made during the test (Wilcoxon signed rank exact test:  $V=17$ ,  $p<0.0001$ ) while  
4043 non-learners did not differ in their fixation time for both stimuli in spite of a tendency to fixate  
4044 more the CS- ( $V=26$ ,  $p=0.05$ ).

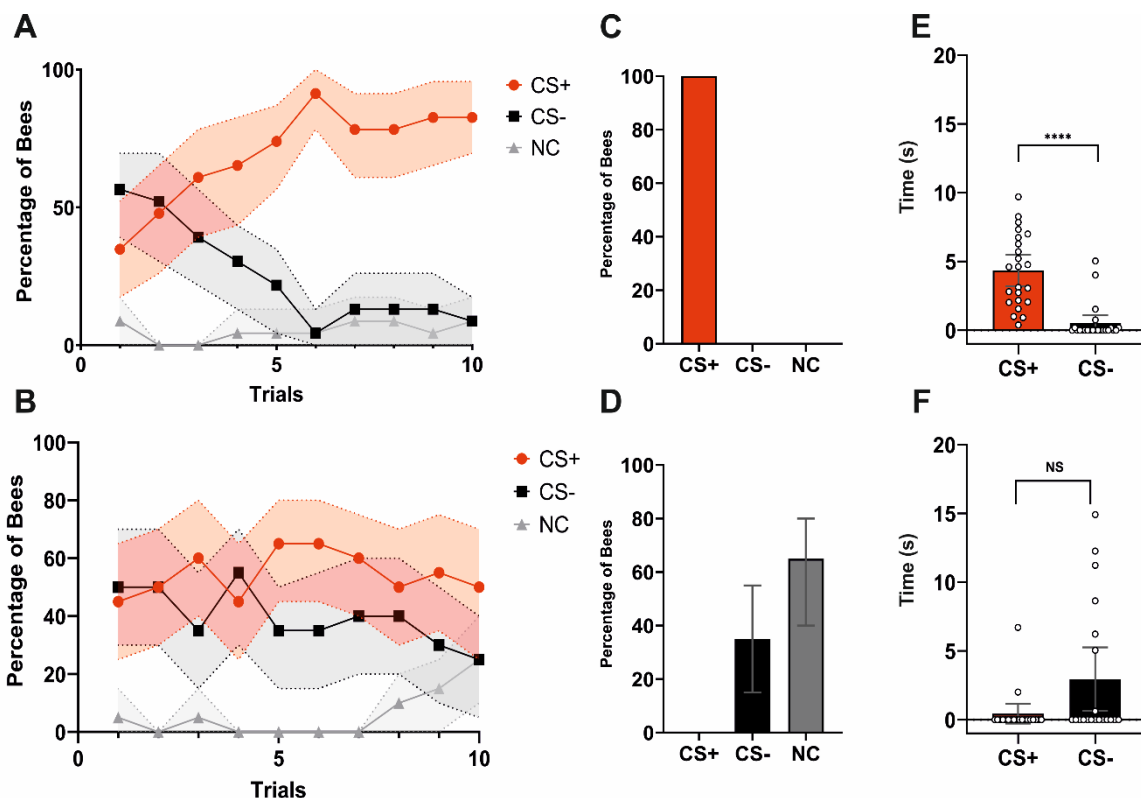

4045

4046 **Figure 2. Acquisition and test performances of learners and non-learners. A) Acquisition**  
 4047 **performance of learners** (i.e. bees that chose the CS+ in the non-reinforced test; n=23). The  
 4048 red, black and grey curves show the percentages of bees choosing the CS+, the CS- or  
 4049 not making a choice (NC), respectively. Bees learned the discrimination between CS+ and CS-. **B)**  
 4050 **Acquisition performance of non-learners** (i.e. bees that chose the CS- or did not make a  
 4051 choice in the non-reinforced test; n=17). These bees did not learn to discriminate the CS+ from  
 4052 the CS-. In **A)** and **B)** shaded areas around curves indicate the 95% confidence interval. **C) Test**  
 4053 **performance of learners** (% of bees choosing either the CS+, the CS- or not making a  
 4054 choice). Per definition these bees only chose the CS+ first. **D) Test performance of non-learners.** (%  
 4055 of bees choosing either the CS+, the CS- or not making a choice). Per definition these bees  
 4056 chose either the CS- or did not make a choice (NC). In **C)** and **D)**, error bars represent the 95%  
 4057 confidence interval. **E) Time (s) spent by learners fixating the CS+ and the CS- during the**  
 4058 **test.** Learners spent more time fixating the CS+ consistently with their stimulus choice. Bars  
 4059 represent the time spent keeping the object within  $-12.5^{\circ}/+12.5^{\circ}$  in front of the bee. Scatter plots  
 4060 represent individual fixation times. \*\*\*\*:  $p < 0.0001$ . **F) Time (s) spent by non-learners**  
 4061 **fixating the CS+ and the CS- during the test.** Non-learners did not differ in their fixation time  
 4062 of the CS+ and the CS-. Bars represent the time spent keeping the object within  $-12.5^{\circ}/+12.5^{\circ}$   
 4063 in front of the bee. Scatter plots represent individual fixation times. NS: non-significant. In **E)**  
 4064 and **F)**, error bars represent the 95% confidence interval.

4065

## 4066 **Molecular analyses**

4067 We aimed at determining if visual learning in the 2D VR induces transcriptional changes  
4068 revealing the neural trace of the associative learning described in the previous section. To this  
4069 end, we performed RT-qPCR in individual brains of learners (n=22; one learner brain was lost  
4070 during the dissection process) and non-learners (n=17), focusing on three main brain sections  
4071 (Fig. 3A): the optic lobes (OLs), the calyces of the mushroom bodies (MB) and the remaining  
4072 central brain (CB), which included mainly the central complex, the subesophageal zone and the  
4073 peduncula of the mushroom-bodies ( $\alpha$  and  $\beta$  lobes). Brains were collected one hour after the  
4074 retention test, which ensures that expression of all three genes was already induced (typically,  
4075 from 15 to 90 min in the case of *kakusei*<sup>31, 37</sup> and 30-60 min in the case of *Hr38* and *Egr1*<sup>28, 29</sup>).

4076 Two reference genes were used for the normalization (see Table 1): *Efla* (E=106%) and  
4077 *Actin* (E=110%)<sup>38</sup>. Within-brain structure analyses showed that reference genes did not vary  
4078 between learners and non-learners (t test; all comparisons NS; see Suppl Fig. 3) thus enabling  
4079 further comparisons between these two categories with respect to the three target IEGs. To this  
4080 end, the normalization procedure used the geometric mean of the two reference genes. No cross-  
4081 comparisons between brain regions or genes were performed.

4082 Figures 3 B-D, E-G, and H-J show the relative normalized expression of *kakusei*, *Hr38*  
4083 and *Egr1*, respectively, for the three brain regions considered in the case of *learners and non-*  
4084 *learners*. Significant variations of normalized expression between learners and non-learners  
4085 were found for the three IEGs: in the case of *kakusei* and *Hr38*, these differences were restricted  
4086 to the MBs (*kakusei*: Fig. 3C; two-sample t test;  $t = -2.23$ ;  $df:37$ ;  $p=0.03$ ; *Hr38*: Fig. 3F;  $t = -$   
4087  $2.39$ ;  $df:37$ ;  $p=0.02$ ) while in the case of *Egr1*, they were observed in the optic lobes (*Egr1*:  
4088 Fig. 3H;  $t = -2.32$ ;  $df:37$ ;  $p=0.03$ ). All other within-structure comparisons between learners and  
4089 non-learners were not significant ( $p>0.05$ ). Notably, in the three cases in which significant  
4090 variations of IEG expression were found, learners exhibited a *downregulation* of IEG

4091 expression with respect of non-learners. In addition, from the three cases, two referred to the  
4092 MB calyces, which indicates the important role of this region for visual learning and memory.  
4093

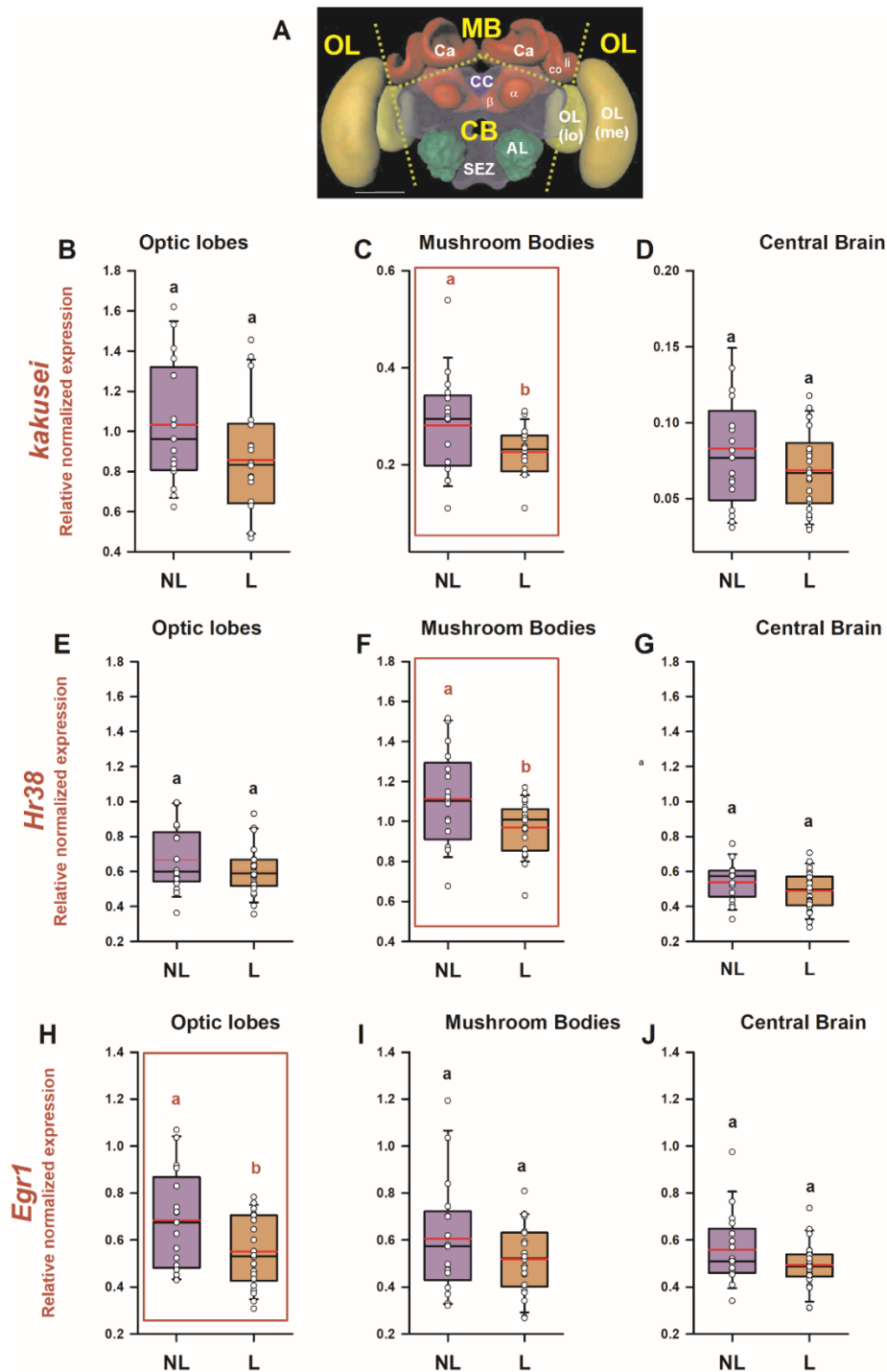

4094

4095 **Figure 3. Differential IEG expression as a consequence of associative color learning in a**  
 4096 **2D VR environment. (A) Honey bee brain with sections used for quantifying IEG**  
 4097 **expression.** Yellow labels indicate the brain regions used for the analysis: MB: mushroom  
 4098 **body; CB: central brain; OL: optic lobes.** The dashed lines indicate the sections performed. Ca:  
 4099 **calyx of the mushroom body; li: lip; co: collar; □ and □: □□ and □□lobes of the mushroom**  
 4100 **body; CC: central complex; AL: antennal lobe; SEZ: subesophagic zone; OL: optic lobe; Me:**  
 4101 **medulla; lo: lobula. Relative normalized expression of (B-D) *kakusei*, (E-G) *Hr38* and (H-**  
 4102 ***Egr1* in three main regions of the bee brain, the optic lobes (B, E, H), the calyces of the**  
 4103 **mushroom bodies (C, F, I) and the central brain (D, G, J). The expression of each IEG was**  
 4104 **normalized to the geometric mean of *Actin* and *Efla* (reference genes). IEG expression was**

4105 analyzed in individual brains of bees belonging to two categories: *learners* (L: conditioned bees  
 4106 that responded correctly and chose the CS+ in their first choice during the non-reinforced test)  
 4107 and *non-learners* (NL: conditioned bees that did not choose the CS+ in their first choice during  
 4108 the non-reinforced test). The range of ordinates was varied between panels to facilitate  
 4109 appreciation of data scatter. In all panels, n=22 for learners and n=17 for non-learners. Different  
 4110 letters on top of box plots indicate significant differences (two-sample t test;  $p < 0.05$ ). Box  
 4111 plots show the mean value in red. Error bars define the 10<sup>th</sup> and 90<sup>th</sup> percentiles. Red boxes  
 4112 indicate cases in which significant variations were detected.

Type of gene	Target	Primer sequence 5' >3'	Amplicon length (bp)	E (%)	R <sup>2</sup>
Target genes	<i>Kakusei</i>	CTACAACGTCCTCTTCGATT (forward)	149	96.4	0.991
		CCTACCTTGGTATTGCAGTT (reverse)			
	<i>Hr38</i>	TGAGATCACCTGGTTGAAAG (forward)	118	106	0.995
CGTAGCAGGATCAATTTCCA (reverse)					
Reference genes	<i>Egr1</i>	GAGAAACCGTTCTGCTGTGA (forward)	138	109	0.991
		GCTCTGAGGGTGATTTCTCG (reverse)			
	<i>Efl</i> □	AAGAGCATCAAGAGCGGAGA (forward)	148	106	0.993
CACTC TTAATGACGCCACA (reverse)					
	<i>Actin</i>	TGCCAACACTGTCCTTTCTG (forward)	156	110	0.995
		AGAATTGACCCACCAATCCA (reverse)			

4113 **Table 1.** Primer sequences used to quantify RNA expression of genes of interest and reference  
 4114 genes by RT-qPCR. Amplicon length (bp), efficiency (E, %) and the coefficient of correlation  
 4115 obtained for the standard curve (R<sup>2</sup>) are also shown. *Hr38*: Hormone receptor 38 gene; *Egr1*:  
 4116 Early growth response gene-1; *Efl* $\alpha$ : Elongation factor 1  $\alpha$  gene.  
 4117

## 4118 Discussion

4119 The present work studied visual learning under a restrictive 2D VR environment and confirmed  
4120 that bees can learn to discriminate visual stimuli based on their color under these artificial  
4121 conditions. Walking parameters did not differ between learners and non-learners so that  
4122 changes in IEG expression could be ascribed to learning success. We showed that associative  
4123 color learning leads to a downregulation of the three IEGs considered in different areas of the  
4124 visual circuit. While *Egr1* was downregulated in the optic lobes, *Hr38* and *kakusei* were  
4125 coincidentally downregulated in the MB calyces. Our work thus reveals that the neural trace of  
4126 associative color learning in the bee brain is distributed along the sequential pathway of color  
4127 processing and highlights the importance of MBs for color learning in bees.

4128

### 4129 IEG downregulation in the bee brain

4130 We observed an IEG *downregulation* both in the optic lobes and the calyces of the MBs. This  
4131 phenomenon is interesting as increased neural activity resulting from experience-dependent  
4132 phenomena is usually reflected by an *upregulation* of IEG expression<sup>24</sup>. Typically, upon neural  
4133 responses, a relatively rapid and transient pulse of gene expression may occur, which  
4134 corresponds to an experience-dependent activation of the underlying synaptic circuitry<sup>23, 39</sup>. In  
4135 our case, however, the downregulation observed indicates that a different form of experience-  
4136 dependent change in neural activity occurred as a consequence of learning. A possible  
4137 explanation for this phenomenon may put the accent on an inhibition of neural activity in key  
4138 visual areas – optic lobes and mushroom bodies - of the learner group.

4139 In the optic lobes, *Egr1* downregulation may correspond to an increased GABAergic  
4140 inhibitory activity associated with learning. The optic lobes exhibit multiple GABAergic fibers  
4141 distributed principally in the medulla and the lobula<sup>40</sup> so that neural activity in these regions is  
4142 subjected to intense GABAergic inhibitory signaling. Higher GABAergic activity has been

4143 reported in the optic lobes of forager bees *via* quantification of *Amgad*, the honey bee homolog  
4144 of the gene responsible for synthesizing the enzyme GAD<sup>41</sup>, which catalyzes the  
4145 decarboxylation of glutamate to GABA. This increase was accompanied by an increase in  
4146 *kakusei*<sup>41</sup>, which we did not observe. Yet, we did not study foraging behavior in a natural  
4147 context, but associative learning in a controlled laboratory context. Natural foraging may  
4148 involve multiple behavioral components and stimulations that may be responsible for the  
4149 increase of *kakusei* that was absent in our study. The interesting finding is, however, that *Amgad*  
4150 expression revealed higher GABAergic neuron activity in the optic lobes of foragers,  
4151 confirming the importance of inhibitory feedback for sustaining experience-dependent visual  
4152 responses. This conclusion is supported by observed increases of GABA titers in the honey bee  
4153 optic lobes upon restart of foraging activities<sup>42</sup> and by findings in fruit flies indicating that  
4154 GABA-ergic neurons in the optic lobes are involved in tuning the sensitivity and selectivity of  
4155 different visual channels<sup>43,44</sup>.

4156         In the calyces of the MBs, where coincident downregulation of *kakusei* and *Hr38* was  
4157 found, neural inhibition is provided by GABAergic feedback neurons (the so-called Av3  
4158 neurons)<sup>45</sup>, which are responsible for the sparse coding responses exhibited by Kenyon cells,  
4159 the constitutive neurons of the MBs. Similar GABAergic neurons exist in fruit flies, which  
4160 provide inhibitory feedback to the MBs. These neurons, termed APL (anterior paired lateral)  
4161 neurons, are necessary for discrimination learning of similar odorants. When flies are trained  
4162 to discriminate odorants in a simple differential conditioning, disrupting the Kenyon cell-APL  
4163 feedback loop decreases the sparseness of Kenyon cell odor responses, increases inter-odor  
4164 correlations and prevents flies from learning to discriminate similar, but not dissimilar, odors<sup>46</sup>.  
4165 Inhibitory feedback onto the calyces of honey bees is needed for solving patterning tasks in  
4166 which insects have to suppress summation of responses to single elements previously rewarded  
4167 when they are presented in an unrewarded compound<sup>47</sup> (i.e. animals have to learn to respond to

4168 the elements and not to the compound) or for reversal learning<sup>48</sup>. A similar conclusion applies  
4169 to fruit flies as GABAergic input to the MBs provided by APL neurons also mediates the  
4170 capacity to solve patterning tasks<sup>49</sup>. Increased feedback inhibition at the level of the MBs may  
4171 therefore appear as a hallmark of certain learning phenomena, which require enhanced neural  
4172 sparseness to decorrelate stimulus representations and thus memory specificity. In our  
4173 experiments, both *kakusei* and *Hr38* were subjected to downregulation in the MBs as a  
4174 consequence of learning, a phenomenon that may be due to plastic changes in GABAergic  
4175 signaling in the calyces of the MBs. Importantly, other visual areas such as the central  
4176 complex<sup>50</sup> or the anterior optic tuberculum<sup>51, 52</sup>, among others, could exhibit similar variations  
4177 undetectable for our methods as sectioning the frozen bee brain for molecular analyses does not  
4178 allow a fine dissection of these areas.

4179 IEG downregulation is not a common phenomenon as upregulation is usually reported  
4180 to indicate the presence of neural activation<sup>22</sup>. Our hypothesis on neural inhibition being the  
4181 cause for this downregulation requires, therefore, to be considered with caution. Further  
4182 experiments are necessary to validate it, using – for instance – electrophysiological recordings  
4183 in key areas of the visual circuits of learners to verify that neural activity is indeed sparser  
4184 therein compared to non-learners. In addition, quantifying IEG expression in preparations in  
4185 which neural inhibition has been characterized extensively at the cellular level such as in the  
4186 case of hippocampal and cerebellum slices exhibiting long-term depression (LTD)<sup>53</sup> could be  
4187 also important.

4188

### 4189 **The neural signature of associative learning differs between different forms of VR**

4190 While the main finding in our experiments refer to a downregulation of IEG genes in key  
4191 regions of the visual circuit, our previous work using a different 3D VR system yielded a  
4192 different result<sup>22</sup>. In this 3D VR, bees could explore the virtual surroundings around the stimuli

4193 to be learned (not bars, but cuboids that expanded upon forward movements of the bee) and  
4194 could displace these stimuli laterally and in depth. They explored and learned to discriminate  
4195 the color stimuli proposed to them and their learning success was comparable, yet slightly lower  
4196 than that observed in the 2D VR arena (50% vs. 55%, respectively). IEG analyses comparing  
4197 learners and non-learners in the 3D VR reported an *upregulation* of *Egr1* expression in the MB  
4198 calyces of learners but not of non-learners. No other change was detected for *kakusei* and *Hr38*  
4199 in the same three brain regions considered in the present work<sup>22</sup>.

4200         These differences are difficult to interpret as the 2D and the 3D VR experiments were  
4201 not done simultaneously but in different years, though in similar seasons. In both cases,  
4202 motivated foragers captured at a feeder were used for the experiments. The previous visual  
4203 experience of these foragers may have differed across individual and between years, thus  
4204 leading to differences in performances. This explanation seems, however, rather implausible  
4205 given that in bees rely on the most recent appetitive learning as the one guiding predominantly  
4206 actual choices. In addition, irrespective of differences in the VR environments and the resulting  
4207 difference in VR immersivity, the experiments were done under similar handling conditions  
4208 and using strictly the same behavioral criteria. Gene analyses were also performed under the  
4209 same conditions and using the same materials and methods. Thus, the contrasting results  
4210 obtained in the two VR scenarios may be due to the distinct constraints they imposed to achieve  
4211 discrimination learning and to the fact that the two scenarios may engage different acquisition  
4212 mechanisms for learning visual information. In the 3D scenario, bees explored both the stimuli  
4213 – the vertical color cuboids – and the imaginary empty surroundings; they could return to the  
4214 stimuli if they missed them and walk around them, which added an important exploratory  
4215 component that was absent in the 2D arena. In the latter case, although bees could also bring  
4216 back the stimuli if they missed them by walking too fast, such a control was restricted to the  
4217 frontal plane and did not allow for three-dimensional inspection. *Egr1* upregulation in the 3D

4218 VR upon learning may thus reflect the convergent effects of an exploratory drive and learning  
4219 in a non-constrained environment. It cannot be due to a pure exploration of the environment as  
4220 non-learners exhibited the same motor performances and did not show *Egr1* upregulation.

4221 In the 2D VR, bees were forced to control tightly the lateral displacements of the stimuli  
4222 – the color rectangles – without any further change allowed. This environment and task may  
4223 thus impose a higher stimulus and movement control and force the bee to focus exclusively and  
4224 artificially on lateral stimulus movements to gain access to sucrose reward and avoid aversive  
4225 saline solution. Although in both VR scenarios the background was empty and only the training  
4226 stimuli were visible, the 2D VR missed the expansion of the images upon approach and thus  
4227 lacked of immersivity. In this context, GABA-mediated inhibition may act as a gain control  
4228 mechanism that enhances response efficiency and stimulus control. In the primary visual cortex  
4229 (V1) of vertebrates, GABA inhibition has been proposed to play a fundamental role in  
4230 establishing selectivity for stimulus orientation and direction of motion<sup>54-56</sup>. As the latter is  
4231 particularly important in the 2D VR, enhanced GABA inhibition could be associated with  
4232 learning to master the visual discrimination in this context.

4233 In addition, a different, yet compatible explanation for the different patterns of IEG  
4234 expression found in the 3D and the 2D VR refers to a possible difference in the visual  
4235 acquisition mechanisms recruited by these two scenarios. In a navigation task, body movement  
4236 translates into a displacement and a recognizable change in the visual scene, which can then be  
4237 computed against the available internal information about the displacement<sup>57</sup>. These  
4238 pathfinding, closed-loop actions can be viewed as different from motor actions that are  
4239 contingent on reinforcement such as operant behaviors produced when a visual discriminative  
4240 stimulus is present<sup>58</sup>. In the latter case, vision is also engaged in discrimination learning but in  
4241 a context that is not navigational. Visual learning in the 2D VR could be seen as a form of  
4242 operant learning in which colors define the action to be produced to obtain the appropriate

4243 reinforcement. Thus, the observed difference in IEG expression between the two types of VR  
4244 may reflect a difference in the mechanisms used to reach the rewarded stimulus.

4245

### 4246 **The role of mushroom bodies for visual learning and memory**

4247 Our work highlights the participation of mushroom bodies in visual learning and short-term  
4248 visual retention. Numerous works have demonstrated the necessity of these brain structures for  
4249 the acquisition, storage and retrieval of olfactory memories in bees<sup>8, 59, 60</sup> and other insects<sup>2, 3,</sup>  
4250 <sup>61</sup>. Yet, less is known about their implication in visually-driven behavioral and neural  
4251 plasticity<sup>62, 63</sup>. In our study, the full control over sensory stimulation offered by the VR system  
4252 allowed a sound comparison between the brain of learners and non-learners, which revealed a  
4253 neural signature for visual learning that included the mushroom bodies.

4254         The implication of mushroom bodies in visual learning and memory in the bee is  
4255 expected given the parallels between visual and olfactory inputs at the level of the calyces.  
4256 While afferent projection neurons convey olfactory information to the lip, a subdivision of the  
4257 calyces<sup>64</sup>, afferent neurons from the lobula and the medulla, which are part of the optic lobes,  
4258 convey visual information to other calyx subdivisions, the collar and the basal ring<sup>65, 66</sup>. In spite  
4259 of this similarity, studies addressing the role of mushroom bodies in honey bee visual learning  
4260 and memory remain rare.

4261         Bees learning to associate color lights with the presence or absence of an electric shock  
4262 in a double-compartment box<sup>38, 67</sup> require the ventral lobe of the mushroom bodies to learn to  
4263 avoid the punished color and spend more time in the safe color<sup>68</sup>. In the same study,  
4264 pharmacological blockade of one of the four collars (two per MB) had no effect on  
4265 discrimination learning<sup>68</sup>, which does not exclude a participation of this MB region in this visual  
4266 learning given that the remaining three calyces could compensate for the loss of the blocked  
4267 one. In a different study, upregulation of the dopamine receptor *Amdop1* was found in the

4268 calyces of the MBs when bees were trained to inhibit positive phototaxis towards a colored  
4269 light<sup>38</sup>.

4270 More recently, the implication of MBs in visual navigation was shown in wood ants  
4271 *Formica rufa*, which are innately attracted to large visual cues (i.e. a large vertical black  
4272 rectangle) and which can nevertheless be trained to locate and travel to a food source placed at  
4273 a specific angle away from the attractive black rectangle<sup>69</sup>. When their MB calyces were  
4274 blocked by injection of procaine<sup>70, 71</sup>, ants reverted their trajectories towards the attractive  
4275 rectangle, which suggests a role for mushroom bodies in the dissociation between innate and  
4276 learned visual responses, and in navigational memory<sup>69</sup>. In another study involving the ant  
4277 *Myrmecia midas*, procaine was again used to block MB function *via* delivery into the vertical  
4278 lobes and evaluate the impact of this blockade in orientation in a familiar environment<sup>72</sup>.  
4279 Experienced forager with procaine-inactivated VLs had tortuous paths and were unable to find  
4280 their nest, whereas control ants were well directed and successful at returning home<sup>72</sup>. Overall,  
4281 these two studies on ant navigation indicate that the vertical lobes of MBs are necessary for  
4282 retrieving visual memories for successful view-based navigation.

4283 Studies on the role of MBs for visual learning and memory in fruit flies have yielded  
4284 contradictory findings. Mushroom body deficits do not affect learning success in the flight  
4285 simulator, a setup in which tethered flies in stationary flight learn to avoid quadrants associated  
4286 with specific visual landmarks based on the presence of an aversive heat beam pointed towards  
4287 their thorax<sup>73</sup>. Similarly, learning to discriminate colors in a cylindrical container made of a  
4288 blue-lit and a yellow-lit compartment, one of which was associated with aversive shaking of  
4289 the flies, was not affected in mushroom body mutants<sup>74</sup>. Spatial learning of a non-heated spot  
4290 in an otherwise heated cylindrical arena displaying surrounding visual landmarks is possible in  
4291 the absence of functional mushroom bodies but not of the central complex<sup>75</sup>. Although these  
4292 various results points toward a dispensability of MBs for visual learning in fruit flies<sup>73</sup>,

4293 experiments comparing appetitive and aversive color learning and discrimination question this  
4294 view<sup>76</sup>. When blue and green colors were presented from below in an arena, walking flies  
4295 learned both the appetitive (based on pairing one color with sugar) and the aversive  
4296 discrimination (based on pairing one color with electric shock) but failed if MB function was  
4297 blocked using neurogenetic tools<sup>76</sup>. Furthermore, MBs are required for visual context  
4298 generalization (e.g. generalizing landmark discrimination in a flight simulator in which  
4299 contextual light was switched from blue to green between training and test)<sup>77-79</sup>. Thus, MBs  
4300 participate in different forms of visual learning in fruit flies, although their involvement in these  
4301 phenomena seems to be less clear than in other insects.

4302         Taken together, our results revealed that learning a visual discrimination under a 2D  
4303 VR, in which closed-loop conditions restricted stimulus control to lateral displacements,  
4304 induced a neural signature that spanned the optic lobes and MB calyces and that was  
4305 characterized by IEG downregulation, consistent with an inhibitory trace. This trace may vary  
4306 and become excitatory in more permissive VR conditions in which closed-loop conditions allow  
4307 for 3D exploration during discrimination learning<sup>22</sup>.

4308

4309

## 4310 **Materials and Methods**

4311 Honey bees (*Apis mellifera*) were obtained from our apiary located at the campus of the  
4312 University Paul Sabatier – Toulouse III during September 2021. Only foragers caught upon  
4313 landing on a gravity feeder filled with a 0.9 M sucrose solution were used in our experiments  
4314 to ensure high appetitive motivation. Captured bees were enclosed in individual glass vials and  
4315 then transferred to small cages housing ten bees in average; caged bees had access to *ad libitum*  
4316 water and to 300 µl of 1.5 M sucrose solution. They were kept overnight in an incubator at 28  
4317 °C and 80% humidity. On the next day, they were placed on ice for five minutes to anesthetize

4318 them and facilitate the gluing of a tether to their thorax by means of melted wax (Fig. 1A). After  
4319 being attached to the tether, each bee was placed on a small (5 cm diameter) Styrofoam ball for  
4320 familiarization with the treadmill situation. Bees were provided with 5  $\mu$ l of 1.5 M sucrose  
4321 solution and kept for 3 h in this provisory setup in the dark. They were then moved to the VR  
4322 arena and used for the experiments.

4323         Once in the VR setup, the bee was attached to a holder that allowed adjusting its position  
4324 on the treadmill (Fig. 1B), a polystyrene ball (diameter: 5 cm, weight: 1.07 g) held by a 3D-  
4325 printed support and floating on a constant airflow produced by an air pump (airflow: 555ml/s;  
4326 Aqua Oxy CWS 2000, Oase, Wasquehal, France).

4327

#### 4328 **VR setup**

4329 The VR setup consisted of the treadmill and of a half-cylindrical vertical screen made of semi-  
4330 transparent tracing paper, which allowed presentation of a 180° visual environment to the bee  
4331 (diameter: 268 mm, height: 200 mm, distance to the bee: 9 cm Fig. 1ABC) and which was  
4332 placed in front of the treadmill. The visual environment was projected from behind the screen  
4333 using a video projector connected to a laptop (Fig. 1A). The video projector was an Acer K135  
4334 (Lamp: LED, Maximum Vertical Sync: 120 Hz, Definition: 1280 x 800, Minimum Vertical  
4335 Sync: 50 Hz, Brightness: 600 lumens, Maximum Horizontal Sync: 100.10<sup>3</sup> Hz, Contrast ratio:  
4336 10 000:1, Minimum Horizontal Sync: 30.10<sup>3</sup> Hz)<sup>15</sup>. The movements of the walking bee on the  
4337 treadmill were recorded by two infrared optic-mouse sensors (Logitech M500, 1000 dpi,  
4338 Logitech, Lausanne, Switzerland) placed on the ball support perpendicular to each other.

4339         Experiments were conducted under 2D closed-loop conditions, i.e. rotations of the ball  
4340 displaced the visual stimuli only laterally. To this end, we used a custom software developed  
4341 using the Unity engine (version 2018.3.11f1), open-source code available at

4342 <https://github.com/G-Lafon/BeeVR><sup>21</sup>. The software updated the position of the bee within the  
4343 VR every 0.017 s.

4344

### 4345 **Visual stimuli**

4346 Bees had to discriminate two vertical rectangles (Fig. 1C) based on their different colors and  
4347 association with reward and punishment. The colors of the rectangles (see supplementary Fig.  
4348 S1) were blue (RGB: 0, 0, 255, with a dominant wavelength of 450 nm and an irradiance of  
4349 161000  $\mu\text{W}$ ) and green (RGB: 0, 100, 0, with a dominant wavelength of 530 nm and an  
4350 irradiance of 24370  $\mu\text{W}/\text{cm}^2$ ). They were displayed on a black background (RGB: 0, 0, 0).  
4351 These colors were chosen based on previous work showing their successful learning in the VR  
4352 setup<sup>15, 21</sup>.

4353 Each rectangle had a 5 cm base and occupied the entire vertical extent of the screen. The  
4354 rectangles were positioned at  $-50^\circ$  and  $+50^\circ$  from the bee's body axis at the beginning of each  
4355 trial (Fig. 1D, left). Keeping the object within  $-12.5^\circ$  and  $+12.5^\circ$  in front of the central axis of  
4356 the bee continuously for 1 s was recorded as a choice (Fig. 1D, right).

4357

### 4358 **Conditioning and testing at the treadmill**

4359 Bees were trained using a differential conditioning, which promotes better learning  
4360 performances owing to the presence of penalized incorrect color choice that result in an  
4361 enhancement of visual attention<sup>80</sup>.

4362 Bees were trained during 10 consecutive trials using a differential conditioning  
4363 procedure (Fig. 1E) in which one of the rectangles (i.e. one of the two colors, green or blue)  
4364 was rewarded with 1.5 M sucrose solution (the appetitive conditioned stimulus or CS+) while  
4365 the other rectangle displaying the alternative color (the aversive conditioned stimulus or CS-)  
4366 was associated with 3 M NaCl solution. The latter was used to increase the penalty of incorrect

4367 choices<sup>34-36,81</sup>. To avoid directional biases, the rewarded and the punished color rectangles were  
4368 swapped between the left and the right side of the virtual arena in a pseudo random manner  
4369 along trials.

4370         At the beginning of the experiment, bees were presented with a dark screen. During  
4371 training trials, each bee faced the two rectangles (Fig. 1D, left). Choice of the CS+ rectangle  
4372 was recorded if the bee kept it at the center of the screen (between  $-12.5^\circ$  and  $+12.5^\circ$  of the  
4373 bee's central axis) during 1 s (Fig. 1D, right). Training was balanced in terms of color  
4374 contingencies (i.e. blue and green equally rewarded across bees) based on a random assignment  
4375 by the VR software. If the bee kept the CS+ in the center of the screen continuously during 1 s  
4376 (i.e. if it chose it), the screen was locked on that image for 8 s. This allowed the delivery of  
4377 sucrose solution in case of a correct choice, or of NaCl in case of an incorrect choice. Solutions  
4378 were delivered for 3 s by the experimenter who sat behind the bee and used a toothpick to this  
4379 end. The toothpick contacted first the antennae and then the mouthparts while the screen was  
4380 locked on the visual image fixated by the bee. A different toothpick was used for each tastant.  
4381 Each training trial lasted until the bee chose one of the two stimuli or until a maximum of 60 s  
4382 (no choice). Trials were separated by an inter-trial interval of 60 s during which the dark screen  
4383 was presented. Bees that were unable to choose a stimulus (i.e. that did not fulfill the criterion  
4384 of a choice defined above) in at least 5 trials were excluded from the analysis. From 50 bees  
4385 trained, 40 were kept for analysis (~80%).

4386         After the last training trial, each bee was subjected to a non-reinforced test that lasted  
4387 60 s (Fig. 1E). Test performance allowed distinguishing *learners* (i.e. bees that chose the CS+  
4388 as their first choice in the test) from *non-learners* (i.e. bees that either chose the CS- in their  
4389 first test choice or that did not make any choice during the test). IEG expression was compared  
4390 between these two groups, which had the same sensory experience in the VR setup and which  
4391 differed only in their learning success.

4392

**4393 Brain dissection**

4394 One hour after the test, the bee was sacrificed and its head was instantly frozen in a nitrogen  
4395 solution. The frozen head was dissected on dry ice under a binocular microscope. First, the  
4396 antennae were removed and a window was cut in the upper part of the head capsule, removing  
4397 the cuticle between the compound eyes and the ocelli. Second, the glands and tracheae around  
4398 the brain were removed. Third, the retinas of the compound eyes were also removed.

4399 The frozen brain was cut in three main parts for IEG analyses (Fig. 3A): the optic lobes  
4400 (OL), the upper part of the mushroom bodies (the mushroom-body calyces, MB Ca) and the  
4401 remaining central brain (CB), which included mainly the peduncula of the mushroom-bodies  
4402 ( $\alpha$  and  $\beta$  lobes), the central complex (CC), the antennal lobes (AL) and the subesophageal zone  
4403 (SEZ). Samples were stored at  $-80\text{ }^{\circ}\text{C}$  before RNA extraction. During the dissection process,  
4404 one *learner* brain was lost so that learner sample sizes differ between the behavioral ( $n=23$ ) and  
4405 the molecular analyses ( $n=22$ ).

4406

**4407 RNA extraction and reverse transcription**

4408 The RNAs from the three sections mentioned above (OL, MB Ca and CB) were extracted using  
4409 the RNeasy Micro Kit (Qiagen). The final RNA concentration obtained was measured by  
4410 spectrophotometry (NanoDrop™ One, Thermo Scientific). A volume of  $10\text{ }\mu\text{l}$  containing  $100$   
4411 ng of the RNA obtained was used for reverse transcription following the procedure  
4412 recommended in the Maxima H Minus First Strand cDNA Synthesis kit (Thermo Scientific,  
4413  $0.25\text{ }\mu\text{l}$  of random hexamer primer,  $1\text{ }\mu\text{l}$  of  $10\text{ mM}$  dNTP mix,  $3.75\text{ }\mu\text{l}$  of nuclease free  $\text{H}_2\text{O}$ ,  $4$   
4414  $\mu\text{l}$   $5\text{X}$  RT Buffer and  $1\text{ }\mu\text{l}$  Maxima H Minus Enzyme Mix).

4415

**4416 Quantitative Polymerase Chain Reaction (RT-qPCR)**

4417 All the primers used for target and reference genes generated amplification products of  
4418 approximately 150 bp. The efficiencies of all reactions with the different primers used were  
4419 between 95% and 110 % (Table 1). Their specificity was verified by analyzing melting curves  
4420 of the RT-qPCR products (see Supplementary Fig. S2). Two reference genes (*Efl  $\alpha$*  and *Actin*)  
4421 were used for normalization.

4422 Expression was quantified using a SYBR Green real-time PCR method. Real-time PCR  
4423 were carried out in 384-Well PCR Plates (Bio-Rad) cover with Microseal 'B' PCR Plate Sealing  
4424 Film (Bio-Rad). The PCR reactions were performed using the SsoAdvanced<sup>TM</sup> Universal  
4425 SYBR<sup>®</sup> Green Supermix (Bio-Rad) in a final volume of 10  $\mu$ l containing 5  $\mu$ l of 2X  
4426 SsoAdvanced<sup>TM</sup> Universal SYBR<sup>®</sup> Green Supermix, 2  $\mu$ l of cDNA template (1:3 dilution  
4427 from the reverse transcription reaction), 0.5  $\mu$ l of 10  $\mu$ mol of each primer and 2  $\mu$ l of ultrapure  
4428 water. The reaction conditions were as follows: 95 °C for 30 s followed by 40 cycles of 95 °C  
4429 for 10 s, 55 °C for 30 s and a final step at 95 °C for 10 s followed by a melt curve from 55 °C  
4430 to 95 °C with 0.5 °C per second. The reaction was performed in a CFX384 Touch Real-Time  
4431 PCR Detection System (Bio-Rad) and analyzed with the software Bio-Rad CFX Manager.

4432 Each sample was run in triplicates. If the triplicates showed too much variability ( $SD >$   
4433 0.3), the furthest triplicate was discarded. If the two remaining triplicates still showed too much  
4434 variability ( $SD > 0.3$ ) the sample was discarded. The samples were subjected to a relative  
4435 quantification and normalization. First for each sample and for each reference gene per brain  
4436 region, the relative quantity ( $Q_r$ ) was computed using the difference between the mean Ct value  
4437 of each sample and the highest mean Ct value ( $\Delta Ct$ ), using the following formula:  $Q_r = (1+E)^{\Delta Ct}$   
4438 (with E= efficiency of the reaction). Then a normalization factor for each sample was obtained  
4439 computing the geometric mean of the relative quantities obtained for the reference genes in the  
4440 corresponding samples ( $\Delta\Delta Ct$ ).

4441

4442 **Data analysis and statistics**4443 *Behavioral data*

4444 The first choice of the bees was recorded during the conditioning trials and the non-reinforced  
4445 test. In this way, we established for each trial and test the percentages of bees choosing first  
4446 each of the stimuli displayed or not choosing a stimulus ( $\pm$  95% confidence interval).

4447 Test percentages were analyzed within groups by means of a generalized linear mixed  
4448 model (GLMM) for binomial family in which the individual identity (Bee) was considered as  
4449 a random factor (individual effect) while the choice category (CS+, CS-, NC) was fitted as a  
4450 fixed effect; z values with corresponding degrees of freedom are reported throughout for this  
4451 kind of analysis.

4452 For the acquisition trials, we recorded motor variables such as the total distance walked  
4453 during a trial, and the walking speed. The analysis of these continuous variables was done using  
4454 a linear mixed model (lmer function) in which the individual identity (*Bee ID*) was a random  
4455 factor and the factors *Group* (i.e. learner or non-learner) and *Trial* were fixed.

4456 Statistical analyses were performed using with R 3.5.1<sup>82</sup>. The package lme4 was used  
4457 for GLMMs and LMMs.

4458

4459 *Gene expression data*

4460 Statistical differences in gene expression were assessed for reference genes to check for stability  
4461 and for target genes within a given brain region using One-Factor ANOVA for independent  
4462 groups in the case of multiple comparisons or two-sample T test in the case of dual comparisons.  
4463 Post hoc comparisons between groups were performed by means of a Tukey test following  
4464 ANOVA. No cross-comparisons between brain regions or genes were performed due to within-

4465 area normalization procedures. Statistical analyses were done either with R 3.5.1 software<sup>82</sup> or  
4466 with Statistica 13 Software (TIBCO® Data Science).

4467

### 4468 **Acknowledgements**

4469 We thank the valuable feedback of Profs. Takeo Kubo (University of Tokyo) and Hiroyuki  
4470 Okuno (Kagoshima University, Japan) on our IEG analyses. We also thank Shiori Iino, Hiroki  
4471 Kohno, Benjamin H. Paffhausen, Marco Paoli and Dorian Champelovier for valuable  
4472 discussions and support, and two anonymous reviewers for useful comments on a previous  
4473 version. This work was supported by an ERC Advanced Grant ('Cognibrains') to M.G, who  
4474 also thanks the Institut Universitaire de France (IUF), the CNRS and the University Paul  
4475 Sabatier for support.

4476

### 4477 **Contributions**

4478 The project was conceived by AB, AAW, IM and MG. GL performed all the behavioral  
4479 experiments. HG dissected and sectioned the brains of the bees trained in the VR setup and  
4480 performed all the molecular analyses. Behavioral experiments were supervised by AAW and  
4481 MG. Molecular experiments were supervised by IM and MG. Statistical analyses on behavioral  
4482 data were performed by GL. Statistical analyses on gene-expression data were performed by  
4483 HG and MG. The manuscript was written by MG and was corrected and discussed by all  
4484 authors. MG obtained the funding necessary for this work. All authors reviewed and approved  
4485 the final version of the manuscript.

4486

### 4487 **Ethics declarations**

### 4488 **Competing interests**

4489 The authors declare no competing interests.

4490

4491 **References**

- 4492 1. Giurfa, M., Cognition with few neurons: higher-order learning in insects. *Trends Neurosci* **2013**,  
4493 36 (5), 285-294.
- 4494 2. Heisenberg, M., Mushroom body memoir: from maps to models. *Nat. Rev. Neurosci.* **2003**, 4 (4),  
4495 266-275.
- 4496 3. Cognigni, P.; Felsenberg, J.; Waddell, S., Do the right thing: neural network mechanisms of  
4497 memory formation, expression and update in *Drosophila*. *Curr Opin Neurobiol* **2018**, 49, 51-58.
- 4498 4. Benjamin, P. R.; Kemenes, G.; Kemenes, I., Non-synaptic neuronal mechanisms of learning and  
4499 memory in gastropod molluscs. *Front Biosci* **2008**, 13, 4051-7.
- 4500 5. Giurfa, M., Behavioral and neural analysis of associative learning in the honeybee: a taste from  
4501 the magic well. *J. Comp. Physiol. A* **2007**, 193 (8), 801-824.
- 4502 6. Giurfa, M., Learning and cognition in insects. *Wiley Interdiscip. Rev. Cogn. Sci.* **2015**, 6 (4), 383-  
4503 395.
- 4504 7. Kandel, E. R., The molecular biology of memory storage: a dialogue between genes and  
4505 synapses. *Science* **2001**, 294 (5544), 1030-8.
- 4506 8. Menzel, R., Memory dynamics in the honeybee. *J. Comp. Physiol. A* **1999**, 185, 323-340.
- 4507 9. Menzel, R., The honeybee as a model for understanding the basis of cognition. *Nature Rev*  
4508 *Neurosci* **2012**, 13, 758-768.
- 4509 10. Giurfa, M.; Sandoz, J. C., Invertebrate learning and memory: fifty years of olfactory conditioning  
4510 of the proboscis extension response in honeybees. *Learn Mem* **2012**, 19 (2), 54-66.
- 4511 11. Bitterman, M. E.; Menzel, R.; Fietz, A.; Schäfer, S., Classical conditioning of proboscis extension  
4512 in honeybees (*Apis mellifera*). *Journal of comparative psychology (Washington, D.C. : 1983)*  
4513 **1983**, 97 (2), 107-119.
- 4514 12. Avargues-Weber, A.; Deisig, N.; Giurfa, M., Visual cognition in social insects. *Annu Rev Entomol*  
4515 **2011**, 56, 423-43.
- 4516 13. Schultheiss, P.; Buatois, A.; Avargues-Weber, A.; Giurfa, M., Using virtual reality to study visual  
4517 performances of honeybees. *Curr Opin Insect Sci* **2017**, 24, 43-50.
- 4518 14. Frasnelli, E.; Hempel de Ibarra, N.; Stewart, F. J., The dominant role of visual motion cues in  
4519 bumblebee flight control revealed through virtual reality. *Front. Physiol.* **2018**, 9, 1038.
- 4520 15. Buatois, A.; Flumian, C.; Schultheiss, P.; Avargues-Weber, A.; Giurfa, M., Transfer of visual  
4521 learning between a virtual and a real environment in honey bees: the role of active vision. *Front.*  
4522 *Behav. Neurosci.* **2018**, 12, 139.
- 4523 16. Rusch, C.; Roth, E.; Vinauger, C.; Riffell, J. A., Honeybees in a virtual reality environment learn  
4524 unique combinations of colour and shape. *J Exp Biol* **2017**, 220 (Pt 19), 3478-3487.
- 4525 17. Zwaka, H.; Bartels, R.; Lehfeldt, S.; Jusyte, M.; Hantke, S.; Menzel, S.; Gora, J.; Alberdi, R.;  
4526 Menzel, R., Learning and its neural correlates in a virtual environment for honeybees. *Front.*  
4527 *Behav. Neurosci.* **2018**, 12, 279.
- 4528 18. Rusch, C.; Alonso San Alberto, D.; Riffell, J. A., Visuo-motor feedback modulates neural activities  
4529 in the medulla of the honeybee, *Apis mellifera*. *J Neurosci* **2021**, 41 (14), 3192-3203.
- 4530 19. Buatois, A.; Pichot, C.; Schultheiss, P.; Sandoz, J. C.; Lazzari, C. R.; Chittka, L.; Avargues-  
4531 Weber, A.; Giurfa, M., Associative visual learning by tethered bees in a controlled visual  
4532 environment. *Sci. Rep.* **2017**, 7 (1), 12903.
- 4533 20. Buatois, A.; Laroche, L.; Lafon, G.; Avargues-Weber, A.; Giurfa, M., Higher-order discrimination  
4534 learning by honeybees in a virtual environment. *Eur J Neurosci* **2020**, 51 (2), 681-694.
- 4535 21. Lafon, G.; Howard, S. R.; Paffhausen, B. H.; Avarguès-Weber, A.; Giurfa, M., Motion cues from  
4536 the background influence associative color learning of honey bees in a virtual-reality scenario.  
4537 *Sci. Rep.* **2021**, 11 (1), 21127.
- 4538 22. Geng, H.; Lafon, G.; Avarguès-Weber, A.; Buatois, A.; Massou, I.; Giurfa, M., Visual learning in a  
4539 virtual reality environment upregulates immediate early gene expression in the mushroom  
4540 bodies of honey bees. *Commun Biol* **2022**, (in press).

- 4541 23. Clayton, D. F., The genomic action potential. *Neurobiol Learn Mem* **2000**, *74* (3), 185-216.
- 4542 24. Bahrami, S.; Drabløs, F., Gene regulation in the immediate-early response process. *Advances in*  
4543 *Biological Regulation* **2016**, *62*, 37-49.
- 4544 25. Minatohara, K.; Akiyoshi, M.; Okuno, H., Role of Immediate-Early Genes in Synaptic Plasticity  
4545 and Neuronal Ensembles Underlying the Memory Trace. *Front. Mol. Neurosci.* **2015**, *8* (78), 78.
- 4546 26. Kiya, T.; Kubo, T., Dance type and flight parameters are associated with different mushroom  
4547 body neural activities in worker honeybee brains. *PLoS One* **2011**, *6* (4), e19301.
- 4548 27. Singh, A. S.; Shah, A.; Brockmann, A., Honey bee foraging induces upregulation of early growth  
4549 response protein 1, hormone receptor 38 and candidate downstream genes of the ecdysteroid  
4550 signalling pathway. *Insect Mol Biol* **2018**, *27* (1), 90-98.
- 4551 28. Iino, S.; Shiota, Y.; Nishimura, M.; Asada, S.; Ono, M.; Kubo, T., Neural activity mapping of  
4552 bumble bee (*Bombus ignitus*) brains during foraging flight using immediate early genes. *Sci. Rep.*  
4553 **2020**, *10* (1), 7887.
- 4554 29. Ugajin, A.; Uchiyama, H.; Miyata, T.; Sasaki, T.; Yajima, S.; Ono, M., Identification and initial  
4555 characterization of novel neural immediate early genes possibly differentially contributing to  
4556 foraging-related learning and memory processes in the honeybee. *Insect Mol Biol* **2018**, *27* (2),  
4557 154-165.
- 4558 30. Shah, A.; Jain, R.; Brockmann, A., Egr-1: A candidate transcription factor involved in molecular  
4559 processes underlying time-memory. *Front. Psychol.* **2018**, *9* (865), 865.
- 4560 31. Kiya, T.; Kunieda, T.; Kubo, T., Increased neural activity of a mushroom body neuron subtype in  
4561 the brains of forager honeybees. *PLoS One* **2007**, *2* (4), e371.
- 4562 32. Fujita, N.; Nagata, Y.; Nishiuchi, T.; Sato, M.; Iwami, M.; Kiya, T., Visualization of neural activity  
4563 in insect brains using a conserved immediate early gene, Hr38. *Curr Biol* **2013**, *23* (20), 2063-70.
- 4564 33. Duclot, F.; Kabbaj, M., The Role of Early Growth Response 1 (EGR1) in Brain Plasticity and  
4565 Neuropsychiatric Disorders. *Front. Behav. Neurosci.* **2017**, *11* (35), 35.
- 4566 34. de Brito Sanchez, M. G.; Serre, M.; Avarguès-Weber, A.; Dyer, A. G.; Giurfa, M., Learning  
4567 context modulates aversive taste strength in honey bees. *J Exp Biol* **2015**, *218* (Pt 6), 949-59.
- 4568 35. Aguiar, J.; Roselino, A. C.; Sazima, M.; Giurfa, M., Can honey bees discriminate between floral-  
4569 fragrance isomers? *J Exp Biol* **2018**, *221* (Pt 14).
- 4570 36. Ayestaran, A.; Giurfa, M.; de Brito Sanchez, M. G., Toxic but drunk: gustatory aversive  
4571 compounds induce post-ingestional malaise in harnessed honeybees. *PLoS One* **2010**, *5* (10),  
4572 e15000.
- 4573 37. Ugajin, A.; Kiya, T.; Kunieda, T.; Ono, M.; Yoshida, T.; Kubo, T., Detection of neural activity in  
4574 the brains of Japanese honeybee workers during the formation of a "hot defensive bee ball".  
4575 *PLoS One* **2012**, *7* (3), e32902.
- 4576 38. Marchal, P.; Villar, M. E.; Geng, H.; Arrufat, P.; Combe, M.; Viola, H.; Massou, I.; Giurfa, M.,  
4577 Inhibitory learning of phototaxis by honeybees in a passive-avoidance task. *Learn Mem* **2019**, *26*  
4578 (10), 412-423.
- 4579 39. Okuno, H., Regulation and function of immediate-early genes in the brain: beyond neuronal  
4580 activity markers. *Neurosci Res* **2011**, *69* (3), 175-186.
- 4581 40. Schäfer, S.; Bicker, G., Distribution of GABA-like immunoreactivity in the brain of the honeybee. *J*  
4582 *Comp Neurol* **1986**, *246* (3), 287-300.
- 4583 41. Kiya, T.; Kubo, T., Analysis of GABAergic and non-GABAergic neuron activity in the optic lobes of  
4584 the forager and re-orienting worker honeybee (*Apis mellifera* L.). *PLoS One* **2010**, *5* (1), e8833.
- 4585 42. Chatterjee, A.; Bais, D.; Brockmann, A.; Ramesh, D., Search behavior of individual foragers  
4586 involves neurotransmitter systems characteristic for social scouting. *Front Insect Sci* **2021**, *1* (4).
- 4587 43. Keles, M. F.; Hardcastle, B. J.; Stadle, C.; Xiao, Q.; Frye, M. A., Inhibitory interactions and  
4588 columnar inputs to an object motion detector in *Drosophila*. *Cell Rep* **2020**, *30* (7), 2115-2124 e5.
- 4589 44. Keles, M. F.; Frye, M. A., Object-detecting neurons in *Drosophila*. *Curr Biol* **2017**, *27* (5), 680-687.
- 4590 45. Rybak, J.; Menzel, R., Anatomy of the mushroom bodies in the honey bee brain: The neuronal  
4591 connections of the alpha-lobe. *J Comp Neurobiol* **1993**, *334*, 444-465.

- 4592 46. Lin, A. C.; Bygrave, A. M.; de Calignon, A.; Lee, T.; Miesenbock, G., Sparse, decorrelated odor  
4593 coding in the mushroom body enhances learned odor discrimination. *Nat Neurosci* **2014**, *17* (4),  
4594 559-68.
- 4595 47. Devaud, J. M.; Papouin, T.; Carcaud, J.; Sandoz, J. C.; Grunewald, B.; Giurfa, M., Neural  
4596 substrate for higher-order learning in an insect: Mushroom bodies are necessary for configural  
4597 discriminations. *Proc Natl Acad Sci U S A* **2015**, *112* (43), E5854-62.
- 4598 48. Boitard, C.; Devaud, J.-M.; Isabel, G.; Giurfa, M., GABAergic feedback signaling into the calyces  
4599 of the mushroom bodies enables olfactory reversal learning in honey bees. *Front. Behav.*  
4600 *Neurosci.* **2015**, *9*.
- 4601 49. Durrieu, M.; Wystrach, A.; Arrufat, P.; Giurfa, M.; Isabel, G., Fruit flies can learn non-elemental  
4602 olfactory discriminations. *Proceedings of the Royal Society B: Biological Sciences* **2020**, *287*  
4603 (1938), 20201234.
- 4604 50. Honkanen, A.; Adden, A.; da Silva Freitas, J.; Heinze, S., The insect central complex and the  
4605 neural basis of navigational strategies. *J Exp Biol* **2019**, *222* (Pt Suppl 1), jeb188854.
- 4606 51. Mota, T.; Yamagata, N.; Giurfa, M.; Gronenberg, W.; Sandoz, J. C., Neural organization and  
4607 visual processing in the anterior optic tubercle of the honeybee brain. *J Neurosci* **2011**, *31* (32),  
4608 11443-11456.
- 4609 52. Mota, T.; Gronenberg, W.; Giurfa, M.; Sandoz, J. C., Chromatic processing in the anterior optic  
4610 tubercle of the honeybee brain. *J Neurosci* **2013**, *33*, 4-16.
- 4611 53. Massey, P. V.; Bashir, Z. I., Long-term depression: multiple forms and implications for brain  
4612 function. *TINS* **2007**, *30* (4), 176-184.
- 4613 54. Rose, D.; Blakemore, C., Effects of bicuculline on functions of inhibition in visual cortex. *Nature*  
4614 **1974**, *249* (455), 375-7.
- 4615 55. Sillito, A. M., Inhibitory mechanisms influencing complex cell orientation selectivity and their  
4616 modification at high resting discharge levels. *J. Physiol.* **1979**, *289*, 33-53.
- 4617 56. Tsumoto, T.; Eckart, W.; Creutzfeldt, O. D., Modification of orientation sensitivity of cat visual  
4618 cortex neurons by removal of GABA-mediated inhibition. *Exp Brain Res* **1979**, *34* (2), 351-63.
- 4619 57. von Holst, E.; Mittelstaedt, H., Das Reafferenzprinzip. *Naturwissenschaften* **1950**, *37* (20), 464-  
4620 476.
- 4621 58. Skinner, B. F., *The Behavior of Organisms. An Experimental Analysis*. Appleton-Century-Crofts:  
4622 New York, 1938; p 457.
- 4623 59. Menzel, R., The insect mushroom body, an experience-dependent recoding device. *J Physiol*  
4624 *Paris* **2014**, *108* (2-3), 84-95.
- 4625 60. Devaud, J. M.; Papouin, T.; Carcaud, J.; Sandoz, J. C.; Grünwald, B.; Giurfa, M., Neural  
4626 substrate for higher-order learning in an insect: Mushroom bodies are necessary for configural  
4627 discriminations. *Proc Natl Acad Sci U S A* **2015**, *112* (43), E5854-62.
- 4628 61. Guven-Ozkan, T.; Davis, R. L., Functional neuroanatomy of *Drosophila* olfactory memory  
4629 formation. *Learn Mem* **2014**, *21* (10), 519-26.
- 4630 62. Avargues-Weber, A.; Mota, T., Advances and limitations of visual conditioning protocols in  
4631 harnessed bees. *J Physiol Paris* **2016**, *110* (3 Pt A), 107-118.
- 4632 63. Avarguès-Weber, A.; Mota, T.; Giurfa, M., New vistas on honey bee vision. *Apidologie* **2012**, *1*-  
4633 25.
- 4634 64. Kirschner, S.; Kleineidam, C. J.; Zube, C.; Rybak, J.; Grünwald, B.; Rössler, W., Dual olfactory  
4635 pathway in the honeybee, *Apis mellifera*. *J Comp Neurol* **2006**, *499* (6), 933-952.
- 4636 65. Ehmer, B.; Gronenberg, W., Segregation of visual input to the mushroom bodies in the  
4637 honeybee (*Apis mellifera*). *J Comp Neurol* **2002**, *451* (4), 362-73.
- 4638 66. Paulk, A. C.; Dacks, A. M.; Phillips-Portillo, J.; Fellous, J. M.; Gronenberg, W., Visual processing  
4639 in the central bee brain. *J Neurosci* **2009**, *29* (32), 9987-99.
- 4640 67. Kirkerud, N. H.; Schlegel, U.; Giovanni Galizia, C., Aversive learning of colored lights in walking  
4641 honeybees. *Front. Behav. Neurosci.* **2017**, *11*, 94.

- 4642 68. Plath, J. A.; Entler, B. V.; Kirkerud, N. H.; Schlegel, U.; Galizia, C. G.; Barron, A. B., Different  
 4643 roles for honey bee mushroom bodies and central complex in visual learning of colored lights in  
 4644 an aversive conditioning assay. *Front. Behav. Neurosci.* **2017**, *11*, 98.
- 4645 69. Buehlmann, C.; Wozniak, B.; Goulard, R.; Webb, B.; Graham, P.; Niven, J. E., Mushroom Bodies  
 4646 Are Required for Learned Visual Navigation, but Not for Innate Visual Behavior, in Ants. *Curr Biol*  
 4647 **2020**, *30* (17), 3438-3443 e2.
- 4648 70. Devaud, J. M.; Blunk, A.; Poduffall, J.; Giurfa, M.; Grünewald, B., Using local anaesthetics to  
 4649 block neuronal activity and map specific learning tasks to the mushroom bodies of an insect  
 4650 brain. *Eur J Neurosci* **2007**, *26* (11), 3193-206.
- 4651 71. Muller, D.; Staffelt, D.; Fiala, A.; Menzel, R., Procaine impairs learning and memory  
 4652 consolidation in the honeybee. *Brain Res* **2003**, *977* (1), 124-127.
- 4653 72. Kamhi, J. F.; Barron, A. B.; Narendra, A., Vertical Lobes of the Mushroom Bodies Are Essential  
 4654 for View-Based Navigation in Australian Myrmecia Ants. *Curr Biol* **2020**, *30* (17), 3432-3437 e3.
- 4655 73. Wolf, R.; Wittig, T.; Liu, L.; Wustmann, G.; Eyding, D.; Heisenberg, M., *Drosophila* mushroom  
 4656 bodies are dispensable for visual, tactile, and motor learning. *Learn Mem* **1998**, *5* (1-2), 166-78.
- 4657 74. Heisenberg, M.; Borst, A.; Wagner, S.; Byers, D., *Drosophila* mushroom body mutants are  
 4658 deficient in olfactory learning. *J Neurogenet* **1985**, *2* (1), 1-30.
- 4659 75. Ofstad, T. A.; Zuker, C. S.; Reiser, M. B., Visual place learning in *Drosophila melanogaster*.  
 4660 *Nature* **2011**, *474* (7350), 204-U240.
- 4661 76. Vogt, K.; Schnaitmann, C.; Dylla, K. V.; Knapek, S.; Aso, Y.; Rubin, G. M.; Tanimoto, H., Shared  
 4662 mushroom body circuits underlie visual and olfactory memories in *Drosophila*. *Elife* **2014**, *3*,  
 4663 e02395.
- 4664 77. Liu, L.; Wolf, R.; Ernst, R.; Heisenberg, M., Context generalization in *Drosophila* visual learning  
 4665 requires the mushroom bodies. *Nature* **1999**, *400*, 753-756.
- 4666 78. Brembs, B.; Wiener, J., Context and occasion setting in *Drosophila* visual learning. *Learn. Mem.*  
 4667 **2006**, *13* (5), 618-628.
- 4668 79. Tang, S.; Guo, A., Choice behavior of *Drosophila* facing contradictory visual cues. *Science* **2001**,  
 4669 *294*, 1543-1547.
- 4670 80. Avarguès-Weber, A.; Giurfa, M., Cognitive components of color vision in honey bees: how  
 4671 conditioning variables modulate color learning and discrimination. *J. Comp. Physiol. A* **2014**, *200*  
 4672 (6), 449-461.
- 4673 81. Bestea, L.; Rejaud, A.; Sandoz, J. C.; Carcaud, J.; Giurfa, M.; de Brito Sanchez, M. G., Peripheral  
 4674 taste detection in honey bees: What do taste receptors respond to? *Eur J Neurosci* **2021**, *54* (2),  
 4675 4417-4444.
- 4676 82. R Development Core Team, *R: A Language and Environment for Statistical Computing*. The R  
 4677 Foundation for Statistical Computing: Vienna, Austria, 2016.

4678

4679

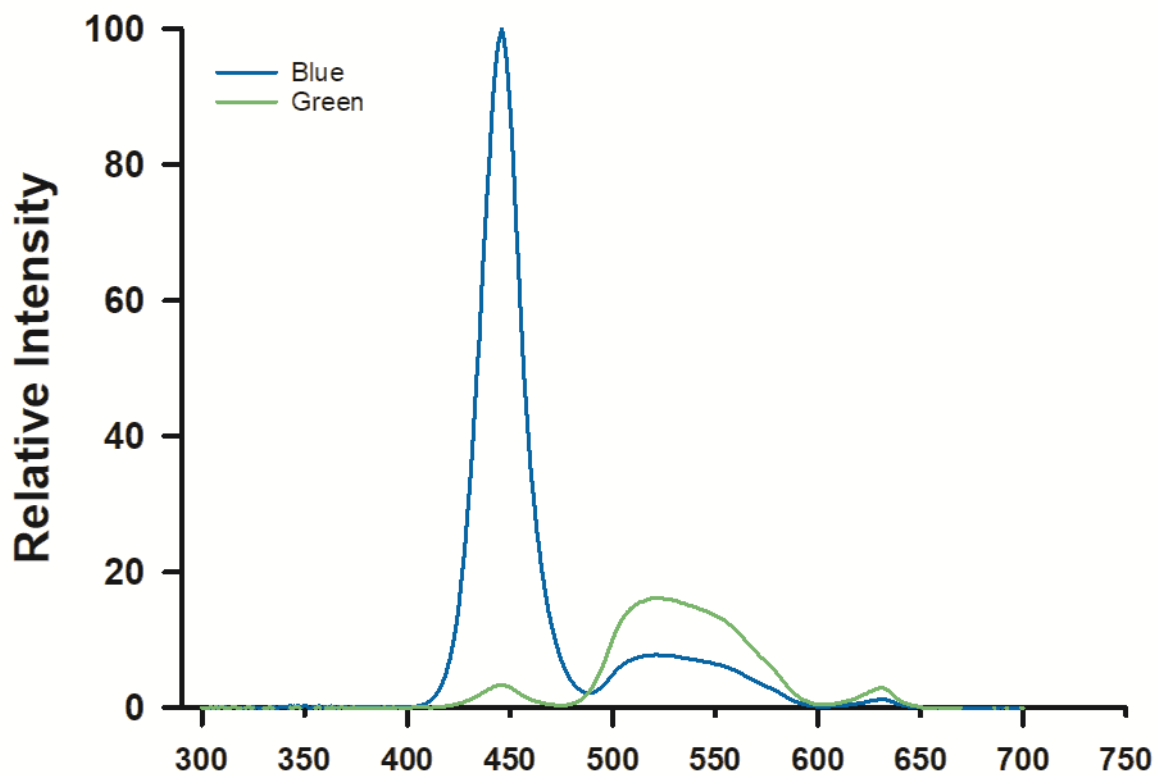
4680 **Supplementary Materials**

4681

4682 **Supplementary Figure 1.** Spectral distribution (relative intensity as a function of wavelength)  
4683 of the blue light (dominant wavelength 446 nm) and the green light (dominant wavelength 528  
4684 nm) used to train the bees in the color discrimination task.

4685

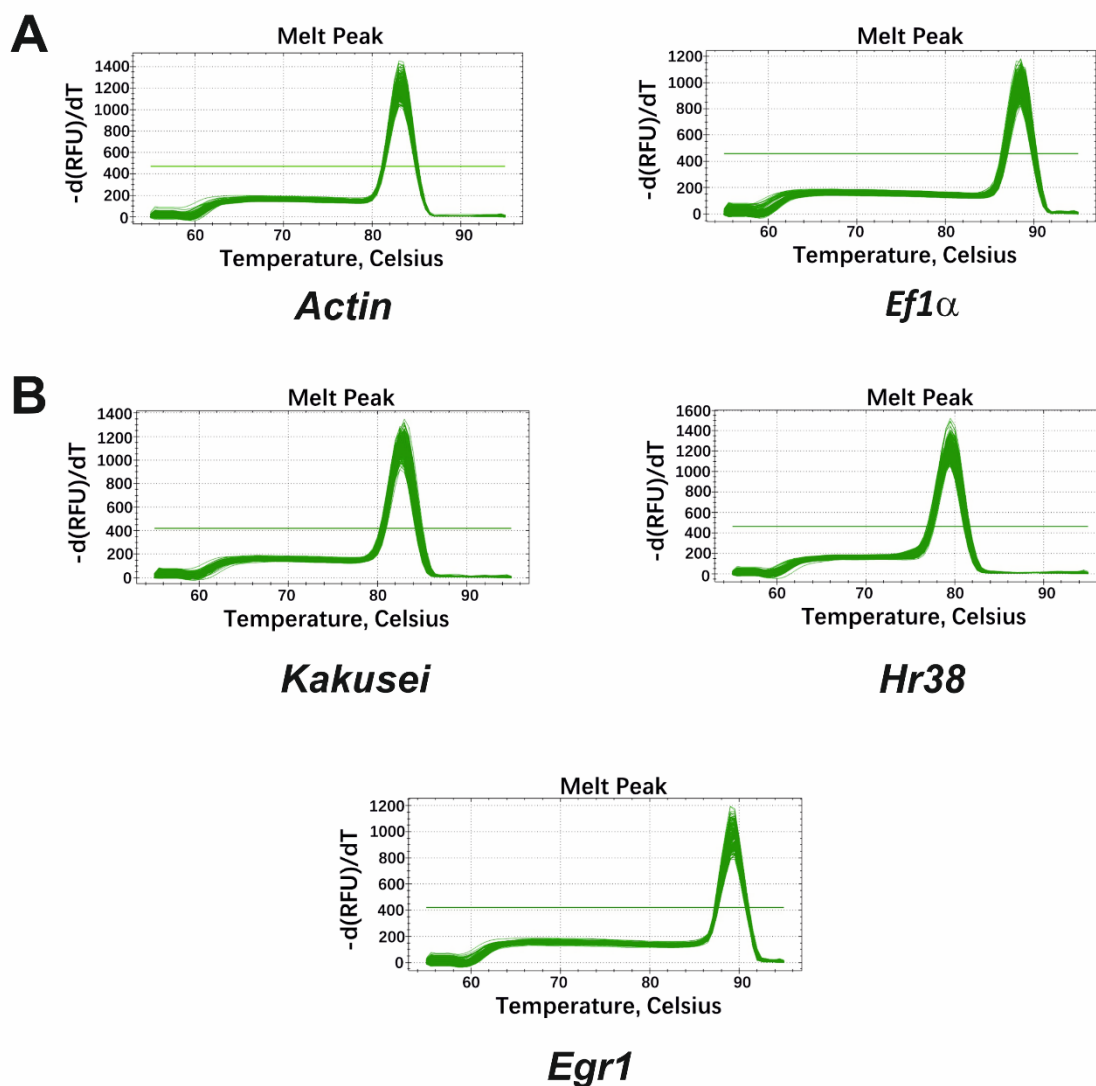

4686

4687 **Supplementary Figure 2. Validation selectivity of gene-specific primers.** Melting peaks of  
 4688 RT-qPCR. **A)** Reference genes. **B)** Target genes.

4689

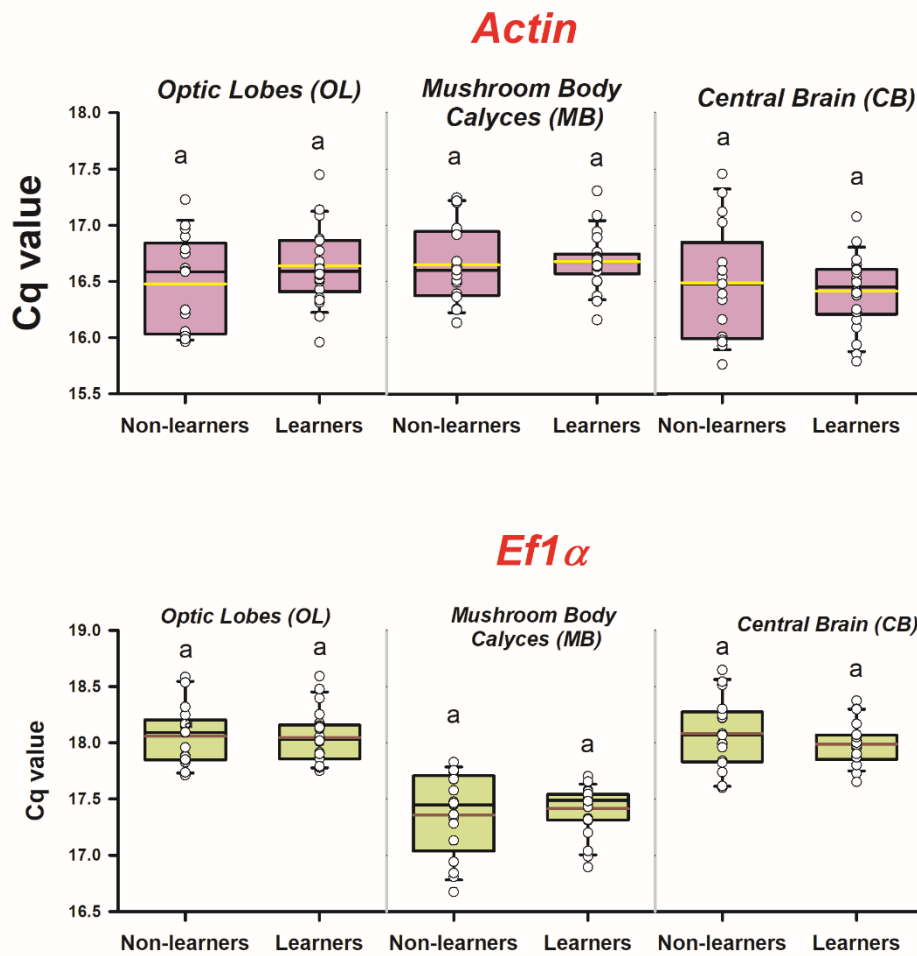

4690  
 4691 **Supplementary Figure 3. Expression levels (Cq values) of the reference genes *Actin* (upper**  
 4692 **row) and *Ef1 $\alpha$*  (lower row).** Expression levels in the brain regions considered (optic lobes,  
 4693 mushroom body calyces and central brain) of learners and non-learners (n=22 and n=17,  
 4694 respectively, for both genes). Box plots show the mean value in yellow (*Actin*) or red (*Ef1 $\alpha$* ).  
 4695 Sample sizes are indicated within parentheses below each group. Error bars define the 10<sup>th</sup> and  
 4696 90<sup>th</sup> percentiles. Same letters on top of box plots indicate absence of significant differences  
 4697 (two-sample t test; p < 0.05).

4698

4699

## Chapter 4

4700

4701 **Comparison of associative visual learning in a 3D virtual reality between**

4702

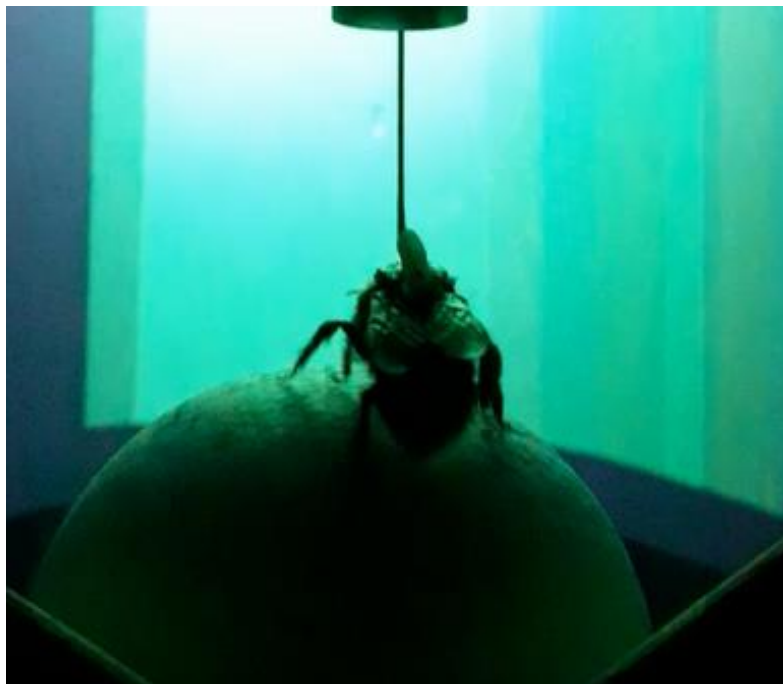
**bumblebees and honeybees**

4703

4704

4705 **Comparison of associative visual learning in a 3D virtual reality between**  
4706 **bumblebees and honey bees.**

4707 **Gregory Lafon<sup>1</sup>, Aurore Avarguès-Weber<sup>1</sup>, Martin Giurfa<sup>1,2,3</sup>**

4708 <sup>1</sup>Research Centre on Animal Cognition, Center for Integrative Biology, CNRS, University of Toulouse,  
4709 118 route de Narbonne, F-31062 Toulouse cedex 09, France.

4710 <sup>2</sup> College of Animal Sciences (College of Bee Science), Fujian Agriculture and Forestry University,  
4711 Fuzhou 350002, China.

4712 <sup>3</sup> Institut Universitaire de France, Paris, France (IUF).

4713

4714 In chapter 2 and 3 we found that color discrimination learning induced a neural signature  
4715 distributed along the sequential pathway of color processing by performing *ex vivo* analysis of  
4716 the brains of learner and non-learner bees. To push our investigations further, we believe it  
4717 would be interesting to use our VR setup for *in vivo* analysis. Preliminary experiments revealed  
4718 that honey bees engage less with the VR after brain surgery. In order to overcome this  
4719 limitation, we decided to investigate the possibility of using bumble bee in VR experiment.  
4720 Bumble bees are closely related to honey bees and known for being more resilient to surgery,  
4721 thus providing a good alternative model for our experiments. By conditioning bumble bees in  
4722 VR, we found that bumble bees are able to solve the color discrimination task with a success  
4723 rate comparable to honey bee. We also found that they engage more and make more choices  
4724 than honey bee, which leads to higher amount of useable data.

4725

4726 **Comparison of associative visual learning in a 3D virtual reality**  
4727 **between bumblebees and honeybees.**

4728

4729 **Gregory Lafon<sup>1</sup>, Aurore Avarguès-Weber<sup>1</sup>, Martin Giurfa<sup>1,2,3</sup>**

4730

4731 <sup>1</sup> Research Centre on Animal Cognition, Center for Integrative Biology, CNRS, University of Toulouse,  
4732 118 route de Narbonne, F-31062 Toulouse cedex 09, France.

4733 <sup>2</sup> College of Animal Sciences (College of Bee Science), Fujian Agriculture and Forestry University,  
4734 Fuzhou 350002, China.

4735 <sup>3</sup> Institut Universitaire de France, Paris, France (IUF).

4736

4737 **Corresponding author:** Dr. Martin Giurfa

4738 Research Centre on Animal Cognition, CNRS – UPS, 31062 Toulouse cedex 9, France

4739 [martin.giurfa@univ-tlse3.fr](mailto:martin.giurfa@univ-tlse3.fr)

4740

## 4741 Introduction

4742 Among insects, honeybees represent a valuable model system for cognitive research. Thanks to  
4743 a rich behavioral repertoire supported by a small brain, they allow easy access to the neural  
4744 correlate of cognitive processes like learning and memory (Giurfa, 2007). The last decades have  
4745 also seen the emergence of bumblebees as a model in cognition (Real, 1992; Dyer and Chittka,  
4746 2004; Worden et al., 2005; Kulahci et al., 2008)

4747 Bumblebees are eusocial central place forager that despite being closely related to honeybees  
4748 differ in a few important points (A. J. Riveros and Gronenberg, 2009). Labor division in  
4749 bumblebees is strongly influenced by size, with larger bees assuming the role of foragers while  
4750 smaller worker stay in the hives (Goulson, 2003). Bumblebees' colonies are smaller than  
4751 honeybees' with only between 200-400 worker instead of the tens of thousands typically found  
4752 in honeybees' hives. This contributes to bumblebees being more easily reared under laboratory  
4753 conditions (A. J. Riveros and Gronenberg, 2009). Bumblebees are solitary foragers, unlike  
4754 honeybees they do not share intentionally information about location and quality of potential  
4755 resources with their nest mates (Leadbeater and Chittka, 2005; Worden et al., 2005; Leadbeater  
4756 and Chittka, 2007) which makes them an interesting model to study foraging strategies  
4757 (Lihoreau et al., 2013).

4758 Related to their central place forager ecology, vision plays a central role in major aspects of  
4759 bumblebees' life histories, from navigation (Church and Plowright, 2006; Saleh and Chittka,  
4760 2007) to floral selection (Dukas and Waser, 1994; Laverty, 1994; Cnaani et al., 2006). In the  
4761 past decades, bumblebees have been extensively used to investigate cognitive processes under  
4762 free flight conditions (Heinrich et al., 1977; Real, 1992; Keasar et al., 1996; Chittka and  
4763 Thomson, 1997; Worden et al., 2005; Cnaani et al., 2006; Kulahci et al., 2008; A. J. Riveros  
4764 and Gronenberg, 2009; Leonard et al., 2011; Mertes et al., 2014; Foster et al., 2014; Robert et

4765 al., 2018; Li et al., 2018; Frasnelli et al., 2021). Bumblebees were also tested in harnessed  
4766 conditions with olfactory conditioning of the PER (Riddell and Mallon, 2006; Andre J. Riveros  
4767 and Gronenberg, 2009; A. J. Riveros and Gronenberg, 2009; Toda et al., 2009; Anfora et al.,  
4768 2011). Initially developed for honeybees (Bitterman et al., 1983), it allows a deep control of the  
4769 different experimental parameters and makes it possible to couple learning paradigms with  
4770 invasive neurobiological techniques (Giurfa and Sandoz, 2012). More recently, visual versions  
4771 of the PER conditioning have also been proposed (Riveros and Gronenberg, 2012; Lichtenstein  
4772 et al., 2015; Muth et al., 2018; Riveros et al., 2020). Not only can bumblebees successfully learn  
4773 in harnessed condition but they are also robust and reliable during electrophysiology recordings  
4774 (Skorupski et al., 2007; Spaethe et al., 2007; Paulk et al., 2008; Paulk and Gronenberg, 2008;  
4775 Skorupski and Chittka, 2010a, 2010b; Vähäkainu et al., 2013; Rusanen et al., 2017) or calcium  
4776 brain imaging (Mertes et al., 2021).

4777 We have recently developed a Virtual reality (VR) setup that allows to successfully train  
4778 restrained honeybees in a visual differential conditioning task (Buatois et al., 2017; Lafon et  
4779 al., 2021). Such a setup is intended to open up further possibilities to explore the underlying  
4780 mechanisms of visual learning by facilitating a live access to the brain of a behaving insect. In  
4781 that context, bumblebees appear like a very interesting model since they display some of the  
4782 rich behavioral repertoire of the honeybees but with a bigger brain and a more robust body  
4783 which make them more compatible with invasive protocols like electrophysiology and calcium  
4784 imaging.

4785 Here we assessed if and how the bumblebee *Bombus terrestris* can learn a visual discrimination  
4786 task under VR conditions. We measured bumblebee's performances during the learning phase  
4787 and a subsequent non-reinforced test and compared them with honeybees conditioned with the  
4788 same protocol. We also performed two conditioning experiments using either NaCl or Quinine  
4789 solutions as a punishment, to find the best way to negatively reinforce a stimulus. Since size

4790 plays an important role in bumblebees' labor division (Goulson, 2003), we could expect larger  
4791 bumblebees, that are usually foragers, to perform better in the color discrimination task than  
4792 smaller workers. Moreover, our 3D VR setup involves a significant motor component as bees  
4793 have to move in the virtual environment to reach the rewarded stimuli, so we hypothesize that  
4794 the insect's strength could impact bee's performances.

## 4795 **Materials and methods**

### 4796 **Study species and collection**

4797 Bumblebees were collected each morning around 9 am from twenty commercial colonies of *B.*  
4798 *terrestris*, sixteen for experiment 2, during July 2021, and four for experiment 3, during  
4799 November 2021 (Koppert, Cavaillon, France) by placing a glass vial at the entrance of the box  
4800 and collecting the workers that came out into the vial. Each colony contained about 200  
4801 workers, brood, and 1 queen. Bumblebees were maintained and tested in the laboratory at 25°C  
4802 and 30–40% relative humidity, under a 12:12 h light:dark photocyclus.

4803 Honey bee foragers (*Apis mellifera*) were obtained from the CRCA apiary located in the campus  
4804 of the University Paul Sabatier during July 2021. Foragers were captured the day before the  
4805 experiment at gravity feeders providing 0.88 M sucrose solution upon landing and before they  
4806 began feeding. Captured bees were enclosed in individual glass vials and then transferred to  
4807 small cages housing ten bees in average; where they had access to *ad libitum* water and 300 µl  
4808 of 1.5 M sucrose solution. They were then kept overnight in an incubator at 28°C and 80%  
4809 humidity.

4810 Bees, bumblebees and honeybees, were cooled on ice for 5 minutes to anesthetize them and  
4811 attach them to their tether. Bees were handled under red light, which ensured a dark  
4812 environment to the insects.

### 4813 Tethering procedure

4814 The tethering procedure was the same for both honeybees and bumblebees, referred to as bees  
4815 in the following paragraphs. The procedure followed the same protocol as described in chapter  
4816 1 (Lafon et al., 2021).

4817 Each bee was tethered by means of a 0.06 g steel needle, 0.5 mm in diameter and 40 mm in  
4818 length, which was fixed to the thorax by melted beeswax. The needle was placed within a 3D  
4819 printed resin tube (Black tough resin Prusa, Prusa Research a. s., Czech republic), 7 mm inner  
4820 diameter, 1 cm outer diameter and 55 mm in length, which was fixed on a holding frame placed  
4821 above the treadmill (Fig.1 A-B). This system allowed the bee to adjust its position in the vertical  
4822 axis once set on the ball, but did not allow rotational movements. The holding frame consisted  
4823 of a vertical black, plastic half frame made of two vertical rectangular supports, 105 mm in  
4824 length, connected to an upper, horizontal rectangular support, 120 mm in length. The latter held  
4825 the black cylinder in the middle (Fig. 1B). After being attached to its tether, each bee was placed  
4826 on a small (50 mm diameter) Styrofoam ball for familiarization to a provisory set-up and  
4827 provided with 5  $\mu$ l of 1.5 M sucrose solution. Each bee was held for 3 h in this provisory setup,  
4828 which was kept in the dark and without visual stimulations.

4829

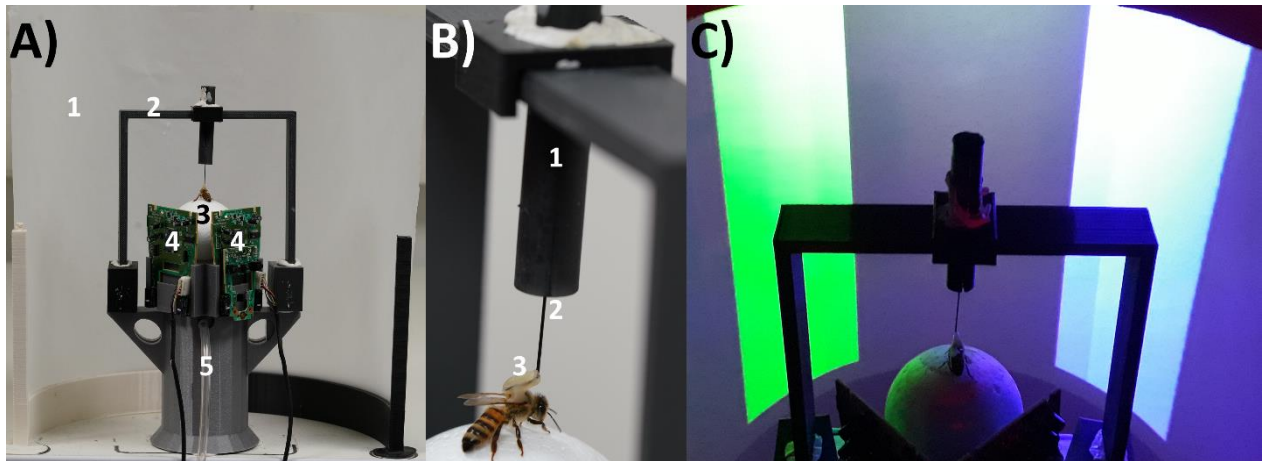

4830

4831 **Figure 1. Experimental setup and 3D environment. A) Global view of the VR system.** 1: Semicircular  
 4832 projection screen made of tracing paper. 2: Holding frame to place the tethered bee on the treadmill.  
 4833 3: The treadmill was a Styrofoam ball positioned within a cylindrical support (not visible) floating on  
 4834 an air cushion. 4: Infrared mouse optic sensors allowing to record the displacement of the ball and to  
 4835 reconstruct the bee's trajectory. 5: Air arrival. The video projector displaying images on the screen  
 4836 from behind can be seen on top of the image. **B) The tethering system.** 1: Plastic cylinder held by the  
 4837 holding frame; the cylinder contained a glass cannula into which a steel needle was inserted. 2: The  
 4838 needle was attached to the thorax of the bee. 3: Its curved end was fixed to the thorax by means of  
 4839 melted bee wax. **C) Color discrimination learning in the VR setup.** The bee had to learn to discriminate  
 4840 two vertical cylinders based on their different color and their association with reward and punishment.  
 4841 Cylinders were green and blue on a dark background. Color intensities were adjusted to avoid  
 4842 phototactic biases independent of learning.

4843

#### 4844 Virtual reality set-up

4845 The bee was then moved to the VR setup (Lafon et al., 2021). The VR relayed on a custom  
 4846 software developed using the Unity engine (version 2020.3.4f1), open-source code available at  
 4847 <https://github.com/G-Lafon/BeeVR>. The software updated the position of the bee within the  
 4848 VR every 0.017 s.

4849 The VR apparatus consisted of a spherical Styrofoam ball (diameter: 50 mm, weight 1.07 g),  
 4850 which acted as a treadmill. The ball was positioned within a 3D-printed, hollow, cylindrical  
 4851 support (cylinder: 50 mm high, 59 mm diameter). The cylinder allowed distributing an upwards  
 4852 air flow of 33 L.min<sup>-1</sup> produced by an AquaOxy 2000 aquarium pump, and released through a  
 4853 small hole at the base of the cylindrical support at a pressure of 1.221 bar. The movements of

4854 the ball were recorded by two infrared optic-mouse sensors (Logitech M500, 1000 dpi) placed  
4855 at a distance of 7 mm from the sphere and forming an angle of 90° angle relative to each other  
4856 (i.e. 45° from the bee body axis).

4857 The ball was positioned in front of a half-cylindrical vertical screen, 268 mm in diameter and  
4858 200 mm height, which was placed at 9 cm from the bee. The screen was made of semi-  
4859 transparent tracing paper, which allowed presentation of a 180° visual environment to the bee.  
4860 The visual environment was projected from behind the screen using a video projector connected  
4861 to a laptop. The video projector was an Acer K135 (Lamp: LED, Maximum Vertical Sync: 120  
4862 Hz, Definition: 1280 x 800, Minimum Vertical Sync: 50 Hz, Brightness: 600 lumens, Maximum  
4863 Horizontal Sync: 100.10<sup>3</sup> Hz, Contrast ratio: 10 000:1, Minimum Horizontal Sync: 30.10<sup>3</sup> Hz).  
4864 The lag between the motion of the bee and the update of the visual surrounding was of 18.00 ±  
4865 2.53 ms (mean ± S.E.; *n* =10) (Lafon et al., 2021).

#### 4866 **Experiment 1: Establishing a balanced pair of green and blue for bumblebee conditioning**

4867 In order to find a pair of colors that elicited the same amount of attraction we recorded the  
4868 spontaneous choice of bumblebee presented with two pairs of green and blue stimulus. One pair  
4869 called Green (R: 0, G:100, B:1.0; irradiance 24 370 μW/cm<sup>2</sup>) versus Bright Blue (R: 0, G:80,  
4870 B:254) and a second pair called Dark Green (R: 0, G:51,B:1.0) versus Blue (R: 0, G:0, B:255;  
4871 irradiance 161 000 μW/cm<sup>2</sup>).

4872 Each cylinder had a 5 cm diameter base and 1 m height so that it occupied the entire vertical  
4873 extent of the screen irrespective of the bumblebee's position. At the beginning of each test, it  
4874 subtended a horizontal visual angle of 6.5° and was positioned either to the left (-50°) or the  
4875 right (+50°) of the tethered insect. Approaching the cylinder resulted in an expansion of its  
4876 horizontal extent (1.7°/cm). A choice was recorded when the bumblebee approached the  
4877 cylinder within an area of 3 cm surrounding its virtual surface and directly faced its center (Fig.  
4878 2A).

4879 Each insect was subjected to two consecutive tests in non-reinforced conditions. One test for  
4880 each pair of colors, the order of presentation of the pairs was random. We recorded what color  
4881 the bumblebee chose first. Each test lasted 180 s and the inter-test interval was 10 s.

4882

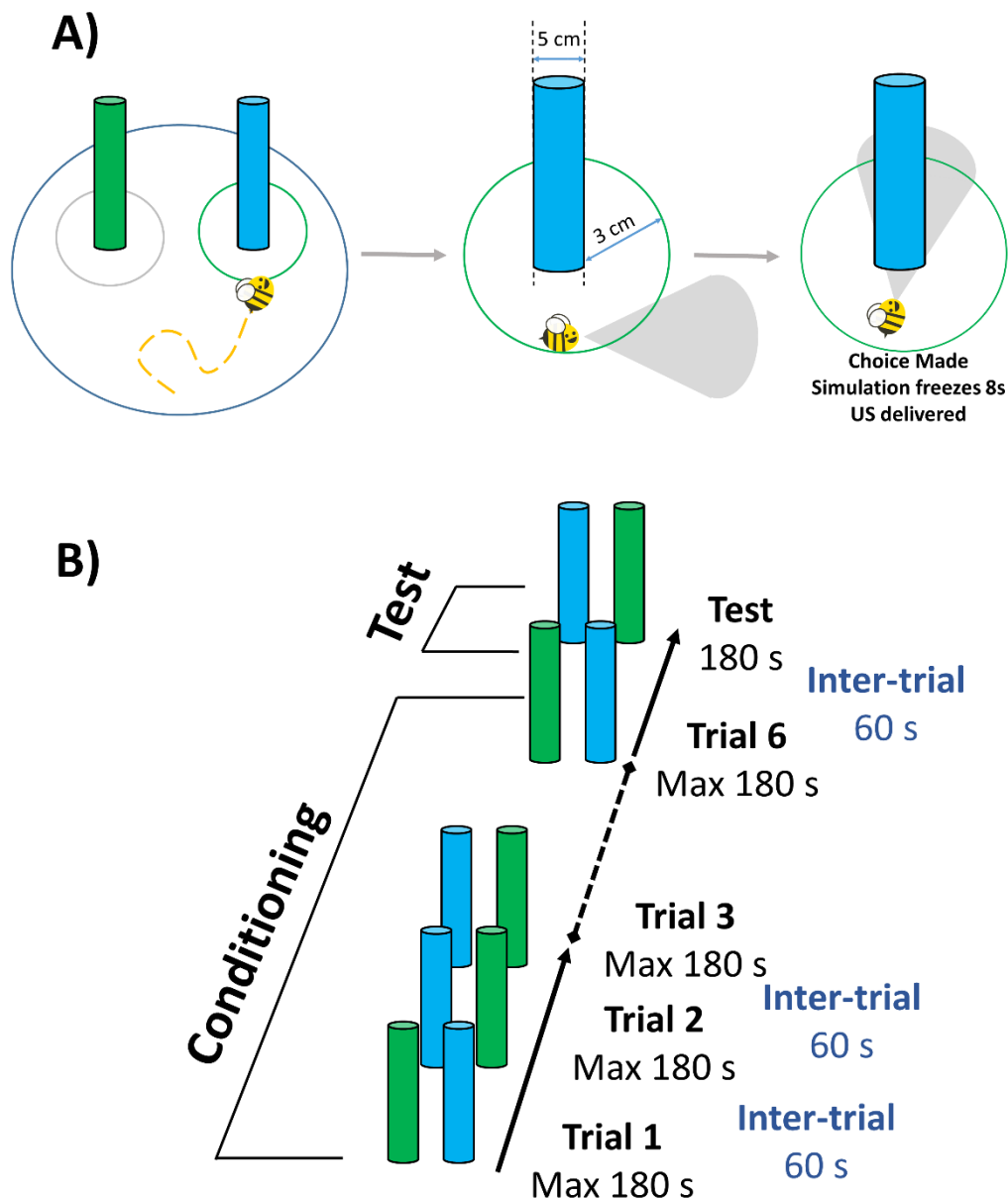

4883

4884 **Figure 2. Choice criterion and conditioning protocol for color discrimination learning. A) Choice**  
 4885 **criterion.** Left: A bee facing the two virtual cylinders. Center: A bee approaching a target cylinder; the  
 4886 cylinder has not yet been centered by the bee (gray area). Right: A bee having centered the target  
 4887 cylinder (gray area). A choice was recorded when the bee reached an area of a radius of 3 cm centered  
 4888 on the cylinder and fixed it frontally. The cylinder image was then frozen during 8 s for honeybees, or  
 4889 14 s for bumblebees, and the corresponding reinforcement (US) was delivered. **B) Conditioning**  
 4890 **protocol.** Bees were trained along 6 conditioning trials that lasted a maximum of 3 min and that were  
 4891 spaced by 1 min (inter-trial interval). After the end of conditioning, and following an additional interval  
 4892 of 1 min, bees were tested in extinction conditions with the two colored cylinders during 3 min.

4893

## 4894 Experiment 2: Comparing performances of bumblebees and honeybees in VR.

4895 Having chosen a pair of colors that elicited the same amount of spontaneous attraction in  
4896 bumblebees (see above), we trained bumblebees and honeybees, to discriminate between two  
4897 vertical colored cylinders, one rewarded and the other not (see *Training and testing procedure*  
4898 below). Both cylinders had the same dimensions of the cylinder employed in the previous  
4899 experiment. For honeybees, one was blue (RGB: 0, 0, 255, with a dominant wavelength of 446  
4900 nm) and the other green (RGB: 0, 51, 0, with a dominant wavelength at 528 nm). Their intensity,  
4901 measured at the level of the bee eye, was 161 000  $\mu\text{W}/\text{cm}^2$  (blue cylinder) and 24 370  $\mu\text{W}/\text{cm}^2$   
4902 (green cylinder). These values were shown to elicit the same level of spontaneous attraction  
4903 (Buatois et al., 2017; Lafon et al., 2021). For bumblebees we used the Dark Green (R: 0, G:51,  
4904 B:1.0) and Blue pair (RGB: 0, 0, 255, with a dominant wavelength of 446 nm) (see results from  
4905 experiment 1).

4906 The cylinders were positioned respectively at  $-50^\circ$  and  $+50^\circ$  from the bee's body axis at the  
4907 beginning of each trial. As in the previous experiment, approaching a cylinder within an area  
4908 of 3 cm surrounding its virtual surface followed by direct fixation of its center was recorded as  
4909 a choice (Fig. 2A).

## 4910 Experiment 3: Conditioning bumblebees with Quinine as punishment

4911 In this experiment we repeated the protocol from the experiment 2 on bumblebees using 1.2g.L<sup>-1</sup>  
4912 quinine solution (Dyer and Chittka, 2004) instead of 3 M NaCl as punishment. All other  
4913 parameters were the same.

## 4914 Training and testing procedure

4915 Both honeybees and bumblebees, were trained during 6 trials using a differential conditioning  
4916 procedure (Fig. 2B) in which one of the cylinders (i.e. one of the two colors, green or blue) was  
4917 rewarded with 1.5 M sucrose solution (the appetitive conditioned stimulus or CS+) while the

4918 other cylinder displaying the alternative color (the aversive conditioned stimulus or CS-) was  
4919 associated with either 3 M NaCl solution (experiment 2) or 1.2 g.L<sup>-1</sup> quinine solution  
4920 (experiment 3).

4921 At the beginning of the experiment, bees were presented with a dark screen for 60 s. During  
4922 training trials, each bee faced the virtual environment with the two cylinders in front of it. The  
4923 bee had to learn to choose the CS+ cylinder by walking towards it and centering it on the screen.  
4924 Training was balanced in terms of color contingencies (i.e. blue and green equally rewarded  
4925 across bees) based on a random assignment by the VR software. If the bee reached the CS+  
4926 within an area of 3 cm in the virtual environment (i.e. the chosen cylinder subtended a horizontal  
4927 visual angle of 53°) and centered, the screen was locked on that image for 8s for honeybees  
4928 (Lafon et al., 2021) or 14 s in case of bumblebees. The screen freezing was longer for  
4929 bumblebees as we found in pre-experiments that they need more time to take the reward from  
4930 the toothpick. This allowed the delivery of sucrose solution in case of a correct choice, or of  
4931 NaCl (experiment 2) or quinine (experiment 3) in case of an incorrect choice. Solutions were  
4932 delivered for 3 s by the experimenter who sat behind the bee and used a toothpick to this end.  
4933 The toothpick contacted first the antennae and then the mouthparts while the screen was locked  
4934 on the visual image fixated by the bee.

4935 Each training trial lasted until the bee chose one stimuli or until a maximum of 180 s (no choice).  
4936 Thus, a single choice (or a no choice) was recorded during each training trial. Trials were  
4937 separated by an inter-trial interval of 60 s during which the dark screen was presented. The bees  
4938 that were unable to choose a stimulus in at least 3 trials were excluded from the analysis. From  
4939 138 bumblebees trained in experiment 2, 123 were kept for analysis (~89%). From 77  
4940 honeybees trained, 31 were kept for analysis (~40%). In the experiment 3, out of 315 trained  
4941 bumblebees, 235 were kept for analysis (~75%). Every animal was frozen at -20°C after the  
4942 experiment to be later weighed and measured.

4943 After the last training trial, each bee was subjected to a non-reinforced test that contrary to  
4944 training trials had a fixed duration of 180 s. During this test, two variables were recorded: the  
4945 first choice (as defined above) and the time spent fixating the rewarded and the non-rewarded  
4946 stimulus. Both variables have been used in prior works performed in our VR setup to  
4947 characterize test performances as they may reveal different aspects of behavioral performances  
4948 (Buatois et al., 2020, 2018, 2017; Lafon et al., 2021). Fixation time (s) was defined as the time  
4949 spent by each cylinder at the center of the screen ( $\pm 2.5$  mm) where it was brought by the bee's  
4950 motor actions. We used the same ray-casting method as in Lafon et al. 2021 (Lafon et al., 2021).

### 4951 **Weight and size measuring**

4952 Size was assessed by measuring the distance between the two wing joints using the Toupview  
4953 software (ToupTek Photonics, Zhejiang, China). After size measurements insects were placed  
4954 in an oven at 70°C for 4 hours in order to evaporate all water from their bodies. Dry weigh was  
4955 measured with a precision scale (OHAUS, Nänikon, Switzerland).

### 4956 **Statistical analysis**

4957 Statistical analyses were performed using R software (R Core Team, 2020). In Experiment 1  
4958 (Color balancing), we counted the number of green and blue choices for each pair. We then  
4959 used a  $\chi^2$  test to compare the distribution of green and blue of each pair with a theoretical  
4960 distribution of 50% green and 50% blue. We report  $\chi^2$ , degrees of freedom and p-values for this  
4961 analysis.

4962 In Experiments 2 and 3, the first choice in each trial and test was categorized as choice of the  
4963 CS+, choice of the CS- or no choice (NC). Thus, a bee choosing the CS+ was recorded as (1,  
4964 0, 0) for choice of the CS+, choice of the CS- and NC, respectively. Data were bootstrapped to  
4965 plot the proportion of bees in each category with their corresponding 95% confidence interval.  
4966 Performances were analyzed using generalized mixed linear models (GLMM) with a binomial

4967 error structure-logit-link function (glmer function of R package lme4) (Bates et al., 2014). The  
4968 independent variables (fixed factors) were the species of bee (*Species*; Experiment 2), the trial  
4969 number (*Trial*), the choice category (*Choice*) and the color of the CS+ when applicable (*Color*:  
4970 Blue or Green). *Bee ID* was included as a random factor to account for the repeated-measure  
4971 design; z values with corresponding degrees of freedom are reported throughout for this kind  
4972 of analysis. Post-hoc ANOVA were performed on those models to assess the impact of each  
4973 factors. We report  $\chi^2$  with corresponding degrees of freedom throughout for this kind of  
4974 analysis.

4975 During the tests of Experiments 2 and 3, we also recorded the time spent fixating the test  
4976 alternatives (CS+ vs. CS-). Time values were compared using a Wilcoxon signed rank test.

4977 For the acquisition trials, we recorded motor variables such as the total distance walked during  
4978 a trial, and walking speed. In addition, we analyzed the latency to make a choice starting from  
4979 the beginning of a trial to the moment in which a choice (either for the CS+ or the CS-) was  
4980 recorded. NC data were excluded from the latency analysis. The analysis of these continuous  
4981 variables was done using a linear mixed model (lmer function of R package lme4) in which the  
4982 individual identity (*Bee ID*) was a random factor and the experimental condition (Condition)  
4983 and trial number (Trial) were fixed factors. Statistical analyses were performed using R version  
4984 4.0.2 (R Core Team, 2020).

## 4985 Results

### 4986 Experiment 1: Establishing a balanced pair of green and blue stimuli

4987 In a first experiment, we recorded the spontaneous choice of bumblebee presented with two  
4988 pairs of green and blue stimulus. One pair called Green (R: 0, G:100, B:1.0; irradiance 24 370  
4989  $\mu\text{W}/\text{cm}^2$ ) versus Bright Blue (R: 0, G:80, B:254) and a second pair called Dark Green (R: 0,  
4990 G:51, B:1.0) versus Blue (R: 0, G:0, B:254; irradiance 161 000  $\mu\text{W}/\text{cm}^2$ ). Each bee was

4991 presented once with both pair in a random order. There was no significant effect of the order  
4992 on the bees' choices ( $z = 1.094$ ,  $p = 0.27$ ). Thus we pooled the data of the two test sequences  
4993 and represented for both pair the number of bee choosing green or blue (Fig. 3).

4994 When presented with a choice between Dark green and Blue, the distribution of choices was  
4995 not significantly different from 50% (Green: 19, Blue: 23,  $\chi^2 = 0.38095$ ,  $df = 1$ ,  $p = 0.54$ ). By  
4996 contrast, with the Green versus Bright Blue pair, the distribution was significantly different  
4997 from a random choice (Green: 28, Blue: 11,  $\chi^2 = 7.41$ ,  $df:1$ ,  $p = 0.0065$ ) as the bees preferred  
4998 the green option. The results indicate that only the Dark Green/Blue pair elicited a balanced  
4999 spontaneous choice. We therefore chose to use this pair of colors in the subsequent experiments.

5000

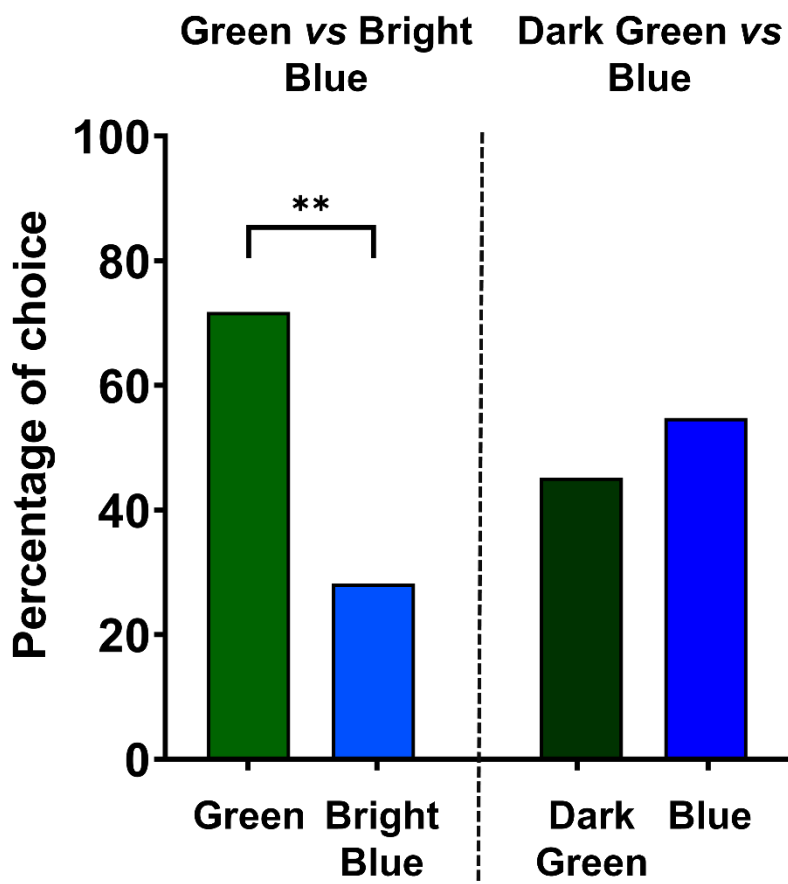

5001

5002 **Figure 3. Experiment 1 - Choosing a balanced pair of green and blue for bumblebee conditioning.**  
 5003 Quantification of the spontaneous phototactic responses of bumblebees ( $N = 51$ ) towards a blue or  
 5004 green cylinder (see Fig. 2A). Two pairs of color were assayed in a random order, one called Green (R:  
 5005 0, G:100, B:1.0; irradiance  $24\ 370\ \mu\text{W}/\text{cm}^2$ ) versus Bright Blue (R: 0, G:80, B:254) and a second pair  
 5006 called Dark Green (R: 0, G:51, B:1.0) versus Blue (R: 0, G:0, B:255; irradiance  $161\ 000\ \mu\text{W}/\text{cm}^2$ ). For  
 5007 each pair, the figure represents percentage of choice of each color. For subsequent experiments, the  
 5008 Dark Green vs Blue pair was used to condition bumblebees.

5009 **Experiment 2: Comparing performances of bumblebees and honeybees**

5010 **in VR**

5011 Bees had to learn to discriminate between a green and a blue cylinder presented against a dark  
 5012 uniform background. They could explore freely the virtual arena for 180 s and a choice was  
 5013 recorded when they got within 3 cm of one cylinder and centered it on the screen. Upon making  
 5014 a choice the bee received either 1.5 M sucrose solution as reward for choosing the CS+ or 3 M

5015 NaCl solution as a punishment associated with the CS-. Conditioning lasted for 6 trials followed  
5016 by one non-reinforced test.

### 5017 Comparing attendance between honeybees and bumblebees

5018 During conditioning we discarded animals that failed to make a choice in 3 trials. Following  
5019 that criterion, the proportion of discarded honeybee (59.74%) was significantly higher than the  
5020 proportion of discarded bumblebees (10,87%) (Fig. 4) ( $z = 6.963$ ,  $p < 0.0001$ ). Overall,  
5021 bumblebees made more choices and were discarded less than honeybees.

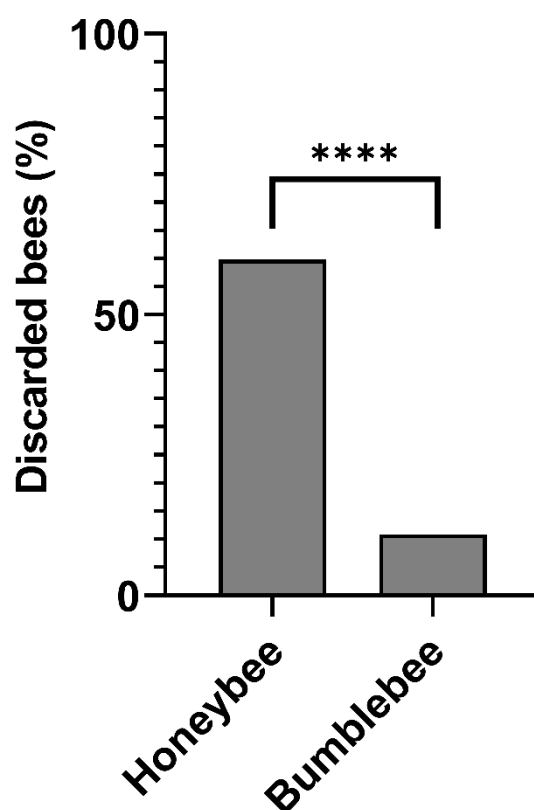

5022

5023 **Figure 4. Experiment 2 - Comparing attendance between honeybees and bumblebees.** Bee that did  
5024 not make a choice for at least 3 of the 6 training trials were discarded. 59.74% of honeybee were  
5025 discarded while only 10.78% bumblebees were. The difference is significant ( $z = 6.963$ ,  $p < 0.0001$ ).

5026

5027 **Discrimination learning during training**

5028 Figure 5 A-B shows the learning curves of both species of bees trained to discriminate the green  
 5029 from the blue cylinder under VR conditions and the cumulative heat maps displaying the  
 5030 locations of the bees in their trajectories during the six acquisition trials. Learning curves were  
 5031 obtained by recording the percentage of bees choosing correctly the CS+ or the CS- in their first  
 5032 choice, or not choosing any stimulus (NC) during each trial. No significant interaction between  
 5033 species, trial number and the bees' choice was found ( $\chi^2 = 4.78$ ,  $df:2$ ,  $p = 0.092$ ), showing that  
 5034 both species followed similar learning dynamic.

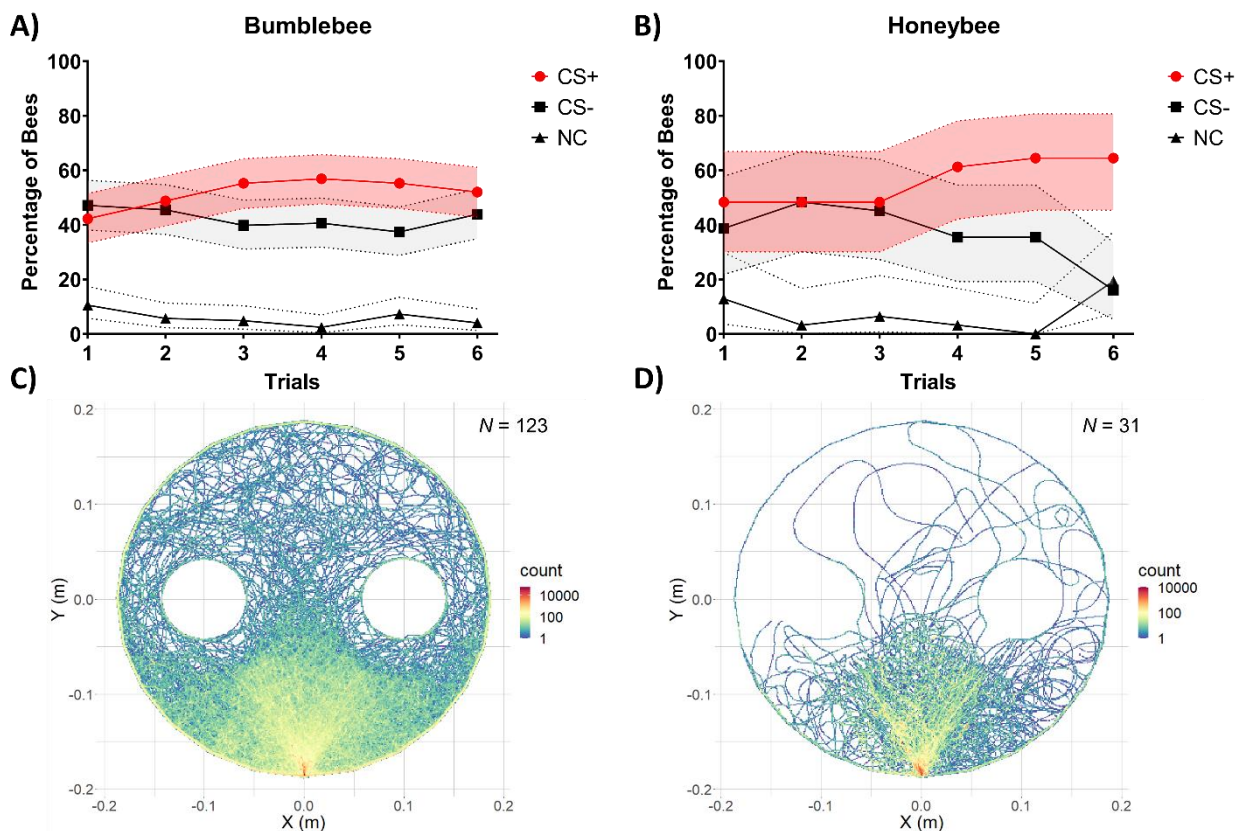

5035

5036 **Figure 5. Acquisition performances in a color discrimination learning task between bumblebees and**  
 5037 **honeybees. (Top)** Acquisition curves in terms of the percentage of bees responding to the CS+ (red),  
 5038 to the CS- (black) or not making any choice (NC; gray) during the six conditioning trials. The pink, light  
 5039 gray and gray areas around the curves represent the 95% confidence interval of CS+, CS- choices and  
 5040 NC, respectively. **(Bottom)** Heat maps of the cumulative coordinates occupied by the bees during the  
 5041 six training trials. Warmer colors depict locations more frequently occupied (see color bar). **A)** Learning  
 5042 curve of bumblebees ( $N = 123$ ). **B)** Learning curve of honeybees ( $N = 31$ ). **C)** Cumulative heat maps of  
 5043 bumblebees' trajectories ( $N = 123$ ). **D)** Cumulative heat maps of honeybees' trajectories ( $N = 31$ ).

#### 5044 Bumblebee learning performances

5045 The color of the CS+ had no effect on the learning of the bumblebees ( $\chi^2 = 0.48$ ,  $df:2$ ,  $p = 0.79$ ).  
5046 Data were thus represented as a CS+ vs. a CS- discrimination irrespective of color identity (Fig.  
5047 5 A). Bumblebees learned to respond more to the CS+ than to the CS- (Fig. 5A). The interaction  
5048 between trial number and bee choices was significant ( $\chi^2 = 7.51$ ,  $df:2$ ,  $p = 0.023$ ). In the course  
5049 of the 6 conditioning trials, the percentages of bees responding to the CS+ and that of bees  
5050 responding to the CS- evolved differently ( $z = 2.06$ ,  $p = 0.04$ ), thus showing successful  
5051 discrimination learning. Moreover, the dynamic of CS+ responding bees was also significantly  
5052 different from that of the non-responding (NC) bees ( $z = 2.31$ ,  $p = 0.021$ ) while the difference  
5053 between the dynamic of the CS- responding bees and the NC bees was not different ( $z = 1.083$ ,  
5054  $p = 0.29$ ). In the corresponding cumulative heat map (Fig. 5C), a clear V shape is visible,  
5055 indicating that the bees did interact with both sides in the VR and walked towards the cylinders.

#### 5056 Honeybee learning performances

5057 The color of the rewarded stimulus had no significant effect on honeybees 'ability to solve the  
5058 discrimination task ( $\chi^2 = 1.903$ ,  $df:2$ ,  $p = 0.39$ ). Data were thus pooled irrespective of the color  
5059 of CS+ (Fig. 5B).

5060 We found a significant interaction between the number of trials and the nature of the honeybees'  
5061 choice ( $\chi^2 = 8.89$ ,  $df:2$ ,  $p = 0.012$ ). Throughout the 6 trials the proportion of CS+ followed a  
5062 different trajectory from that of CS- ( $z = 2.903$ ,  $p = 0.0037$ ), showing that the bees were able to  
5063 successfully learn the discrimination (Fig. 5B). However, the dynamic of NC was neither  
5064 different from CS- ( $z = -1.504$ ,  $p = 0.133$ ) nor from CS+ ( $z = 0.467$ ,  $p = 0.641$ ). The cumulative  
5065 heat map representing the locations of the bees during their training trajectories (Fig. 5D) shows  
5066 that, as with bumblebees, honeybees walked and interacted with both sides in the VR.

## 5067 Motor and temporal components of bee trajectories during training

5068 We analyzed if there was any difference in the displacement of bees during the training trials  
5069 between bumblebees and honeybees (Fig. 6). To do so, we quantified the distance walked (Fig.  
5070 6A), and the walking speed (Fig. 6B) of the bees during each trial. We also measured the choice  
5071 latency in each trial (Fig. 6C), i.e. the time between the beginning of a trial and the first choice  
5072 of the animal.

5073 We found no significant interaction between the trial number and the species of the bees  
5074 (*Trial\*Species*:  $\chi^2$  0.7290, df:1,  $p = 0.40$ ) suggesting no difference in the evolution of distance  
5075 walked across trial between bumblebees and honeybees. The distance was, however,  
5076 significantly affected by the species of the bee (*Species*:  $\chi^2 = 10.91$ , df:1,  $p < 0.001$ ) as  
5077 bumblebees walked more than honeybees (Fig. 6A). But did not vary significantly over trials  
5078 (*Trial*:  $\chi^2 = 3.2609$ , df:1,  $p = 0.071$ ).

5079 The speed was significantly affected by the interaction between species and trials  
5080 (*Trial\*Species*:  $\chi^2$  6.2991, df:1,  $p = 0.012$ ) and by trials alone (*Trial*:  $\chi^2 = 32.5642$ , df:1,  $p <$   
5081  $0.0001$ ). Meaning that both honeybees and bumblebees increased their speed over trials but the  
5082 increase was steeper for honeybees (Fig. 6B). However, there was no speed difference between  
5083 species (*Species*:  $\chi^2 = 2.9235$ , df:1,  $p = 0.087$ ).

5084 The latency to choose decreased significantly across trials (Fig. 6C) (*Trial*:  $\chi^2 = 22.2383$ , df:1,  
5085  $p < 0.0001$ ) at a similar rate in both species (*Trial\*Species*:  $\chi^2$  0.1819, df:1,  $p = 0.6697$ ) and was  
5086 not significantly different overall between bumblebees and honeybees (*Species*:  $\chi^2 = 0.0009$ ,  
5087 df:1,  $p = 0.98$ ).

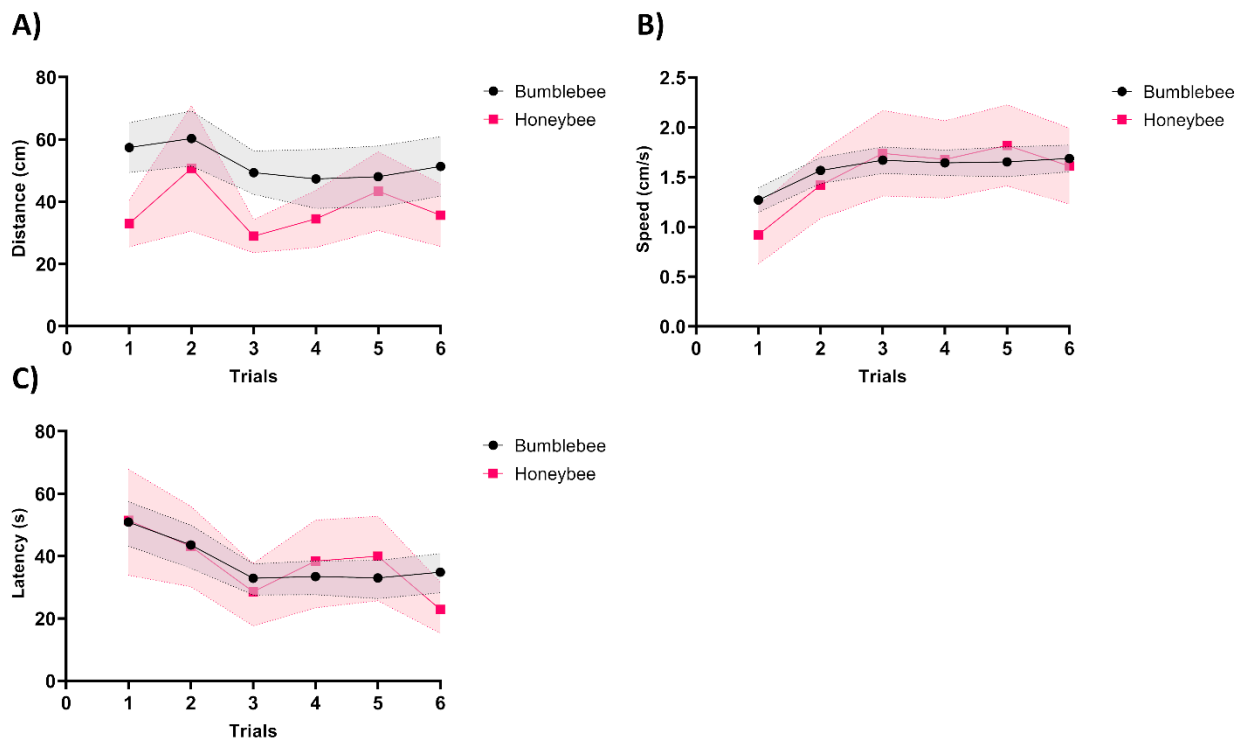

5088

5089 **Figure 6. Motor and temporal components of bee trajectories during the acquisition trials.** For both  
 5090 bumblebees ( $N = 123$ ) and Honeybees ( $N = 31$ ), the evolution of **A)** the distance walked, **B)** the walking  
 5091 speed, and **C)** the choice latency during training trials is shown. The dashed lines above and below the  
 5092 curves represent the 95% confidence interval.

### 5093 Test Performance

5094 After the last training trial, each bee was subjected to a test in which the green and the blue  
 5095 cylinders were presented in extinction conditions (no reinforcement provided). We recorded the  
 5096 percentage of bees choosing correctly the CS+ or the CS- in their first choice, or not choosing  
 5097 (NC) and the time spent fixating the CS+ and the CS- (Fig. 7). Similarly, to the learning phase  
 5098 bee species had no effect on the choices during the non-reinforced test ( $\chi^2 = 0.407$ ,  $df:2$ ,  $p =$   
 5099  $0.816$ ).

### 5100 Bumblebee test performances

5101 Contrary to the training phase, bumblebees' choice was affected by the color of the reward  
 5102 during the test (*Color*:  $\chi^2 = 9.532$ ,  $df:2$ ,  $p = 0.0085$ ). We thus analyzed test results according to  
 5103 the color of reward (Fig. 7A C).

5104 When blue was the rewarded color bumblebees (Fig. 7A) chose the CS+ significantly more than  
 5105 both CS- ( $z = 4.714$ ,  $p < 0.00001$ ) and NC ( $z = 5.882$ ,  $p < 0.00001$ ). The proportion of CS-  
 5106 choices was also superior to the proportion of NC ( $z = -2.575$ ,  $p = 0.01$ ). Bumblebees were thus  
 5107 able to solve the discrimination task during the test when the rewarded stimulus was blue (Fig.  
 5108 7A). However, they did not manage to choose correctly during the test when CS+ was green  
 5109 (Fig. 7C), as the proportion of CS+ was not significantly different from the proportion of CS-  
 5110 ( $z = 0.719$ ,  $p = 0.472$ ). The proportion of NC was significantly less than both CS+ ( $z = 4.643$ ,  
 5111  $p < 0.00001$ ) and CS- ( $z = 4.185$ ,  $p < 0.0001$ ). Similarly, bumblebees did fixate the CS+  
 5112 significantly longer than the CS- when blue was rewarded (Fig. 8A;  $V = 471$ ,  $p = 0.001$ ) but  
 5113 not when green was rewarded (Fig. 8C;  $V = 819$ ,  $p = 0.271$ ).

#### 5114 Honeybees test performances

5115 Contrary to the training phase, and similarly to bumblebees, color of the rewarded stimulus had  
 5116 an effect on honeybees' choice during the test (*Color*:  $\chi^2 = 15.143$ ,  $df:2$ ,  $p < 0.001$ ). We thus  
 5117 represented and analyzed green rewarded and blue rewarded separately (Fig.7B D).

5118 When the rewarded cylinder was blue (Fig.7B) bees chose CS+ significantly more than CS- ( $z$   
 5119  $= 3.238$ ,  $p = 0.001$ ). On the other hand, we found no significant difference neither between the  
 5120 proportion of NC and CS- ( $z = -0.007$ ,  $p = 0.99$ ) nor between NC and CS+ ( $z = 0.008$ ,  $p = 0.99$ ).

5121 When the reward was green (Fig.7D) we found no significant difference between any of the  
 5122 three options (CS+ vs CS-:  $z = -0.743$ ,  $p = 0.46$ ; NC vs CS-:  $z = -1.514$ ,  $p = 0.13$ ; NC vs CS+:  
 5123  $z = 0.819$ ,  $p = 0.41$ ). Thus, like bumblebees, honeybees were only able to solve the  
 5124 discrimination during the test when blue was the rewarded stimulus. When considering  
 5125 centering time (Fig. 8B D), honeybees did not spend significantly more time on CS+ in any of  
 5126 the conditions (Green rewarded: Fig. 8D;  $V = 39$ ,  $p = 0.41$ ; Blue rewarded: Fig.8B;  $V = 44$ ,  $p$   
 5127  $= 0.23$ ).

5128

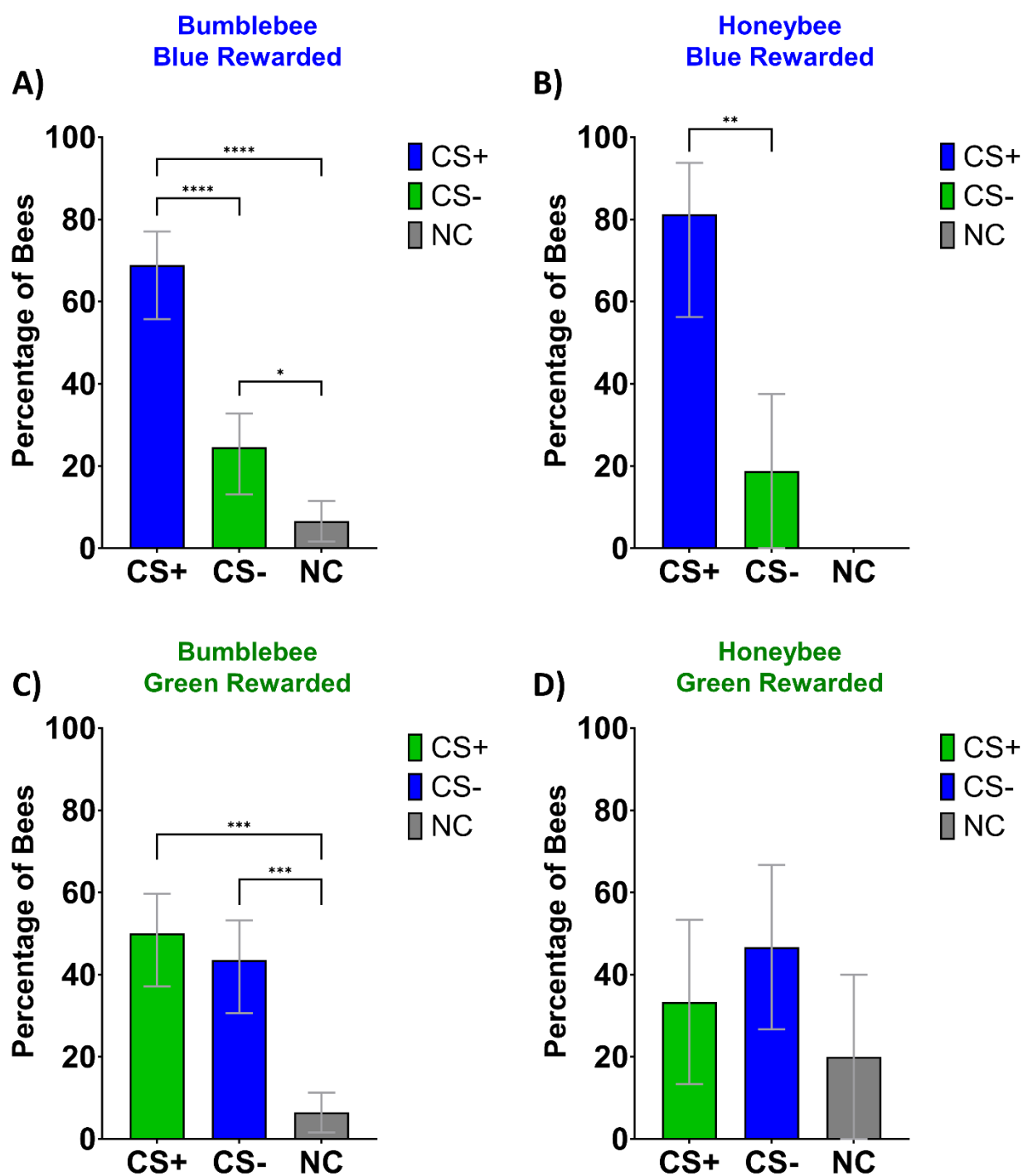

5129

5130 **Figure 7. Test performances in a color discrimination learning task for bumblebees and honeybees.**  
 5131 Percentages of bees choosing each stimulus (CS+: rewarded, CS-: punished, NC: no choice) during the  
 5132 non-reinforced test. Results are represented according to the color of the rewarded stimulus. **Left**  
 5133 Shows 1<sup>st</sup> choices from bumblebees ( $N = 123$ ) when **A)** blue was rewarded ( $N = 61$ ) and when **C)** green  
 5134 was rewarded ( $N = 62$ ). **Right** Shows 1<sup>st</sup> choices from honeybees ( $N = 31$ ) when **B)** blue was rewarded  
 5135 ( $N = 16$ ) and when **D)** green was rewarded ( $N = 15$ ).

5136

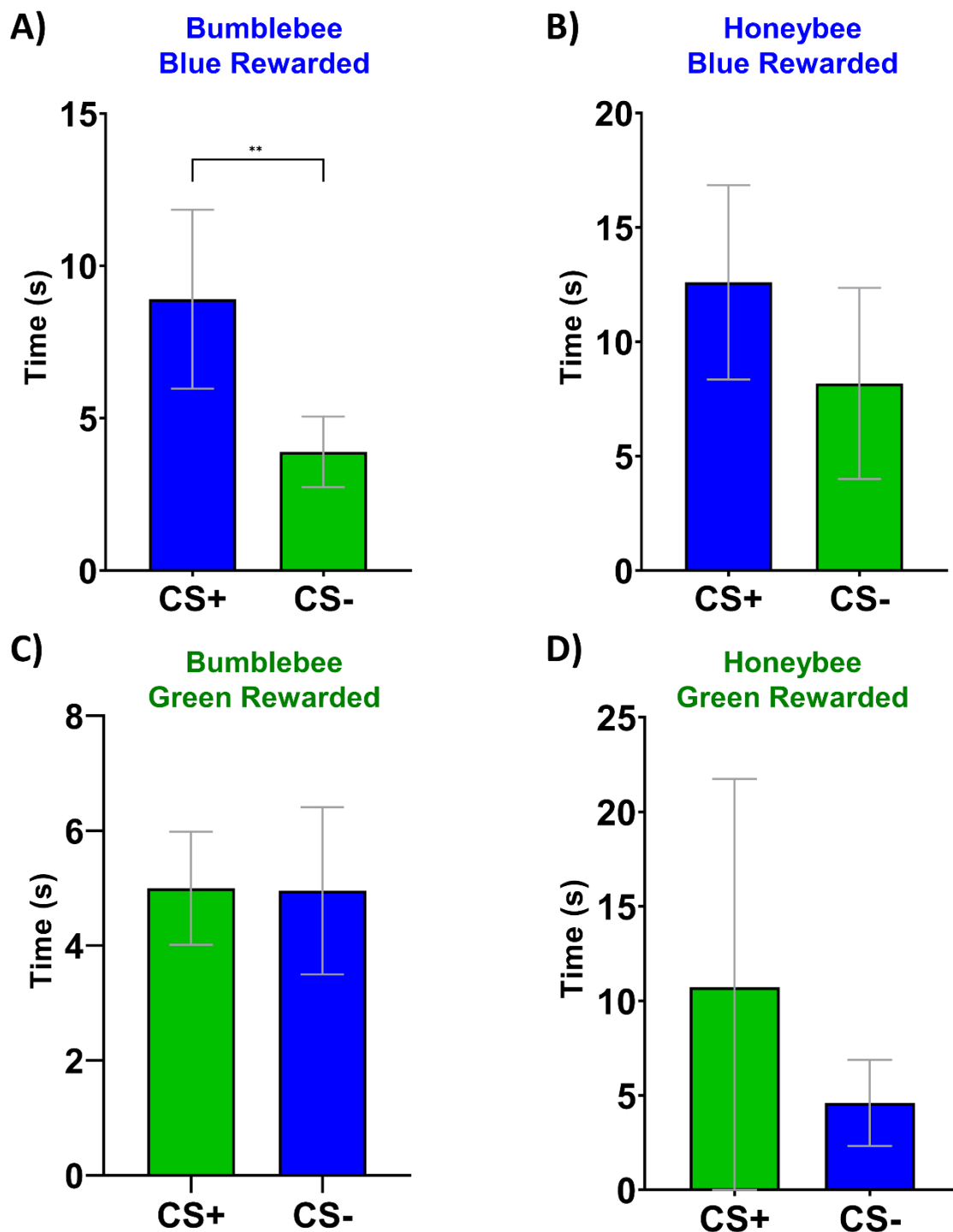

5137

5138 **Figure 8. Fixation time during the non-reinforced test.** Time spent fixating either the CS+ or the CS-  
 5139 during the test. Bars represent the mean fixation time. Error bar represent the 95% confidence interval.  
 5140 Results are represented according to the color of the rewarded stimulus. **Left** Shows time from  
 5141 bumblebees ( $N = 123$ ) when **A)** blue was rewarded ( $N = 61$ ) and when **C)** green was rewarded ( $N = 62$ ).  
 5142 **Right** Shows times from honeybees ( $N = 31$ ) when **B)** blue was rewarded ( $N = 16$ ) and when **D)** green  
 5143 was rewarded ( $N = 15$ ).

5144

5145 **Insect dimensions and performances during the test**

5146 After training we measure the inter wing distance and the dry weight of every bee. When then  
5147 explored if and how did the dimensions of the insects affected their performances during the  
5148 test (Fig. 9, 10, 11). Larger bumblebees walked further than smaller ones (Fig. 9A), as distance  
5149 walked was positively correlated with the size of the insect ( $F = 6.4756$ ,  $df:1$ ,  $p = 0.012$ ) but  
5150 not with weight (Fig. 10A) ( $F = 0.3171$ ,  $df:1$ ,  $p = 0.57$ ). On the other hand, distance walked  
5151 correlated neither with size (Fig. 9B;  $F = 1.0977$ ,  $df:1$ ,  $p = 0.30$ ) nor with weight (Fig. 10B;  $F$   
5152  $= 1.1189$ ,  $df:1$ ,  $p = 0.30$ ) in honeybees. Larger bumblebees also walked faster than smaller ones  
5153 (Fig. 9C) as speed was positively correlated with size in bumblebees ( $F = 6.4179$ ,  $df:1$ ,  $p =$   
5154  $0.013$ ) but not with weight (Fig.10C;  $F = 0.2985$ ,  $df:1$ ,  $p = 0.59$ ) and neither with size (Fig. 9D;  
5155  $F = 1.0942$ ,  $df:1$ ,  $p = 0.30$ ) nor with weight (Fig. 10D;  $F = 1.1113$ ,  $df:1$ ,  $p = 0.3$ ) in honeybees.  
5156 Coherent with the effect observed on speed, bumblebees' latency to choose was negatively  
5157 correlated with both size (Fig. 9E;  $F = 19.496$ ,  $df:1$ ,  $p < 0.0001$ ) and weight (Fig. 10E;  $F =$   
5158  $6.8365$ ,  $df:1$ ,  $p = 0.01$ ). Meaning that bigger bumblebees made their first choice faster, which  
5159 makes sense considering they also walked faster (Fig.9 A). For honeybees however, we found  
5160 no clear effect of size (Fig. 9F) or weight (Fig. 10F) on the latency to choose (*Size*:  $F = 0.8738$ ,  
5161  $df:1$ ,  $p = 0.36$ ; *Weight*:  $F = 0.1025$ ,  $df:1$ ,  $p = 0.75$ ). It is likely that the weight and size variations  
5162 in honeybees are too small to significantly impact motor performances.

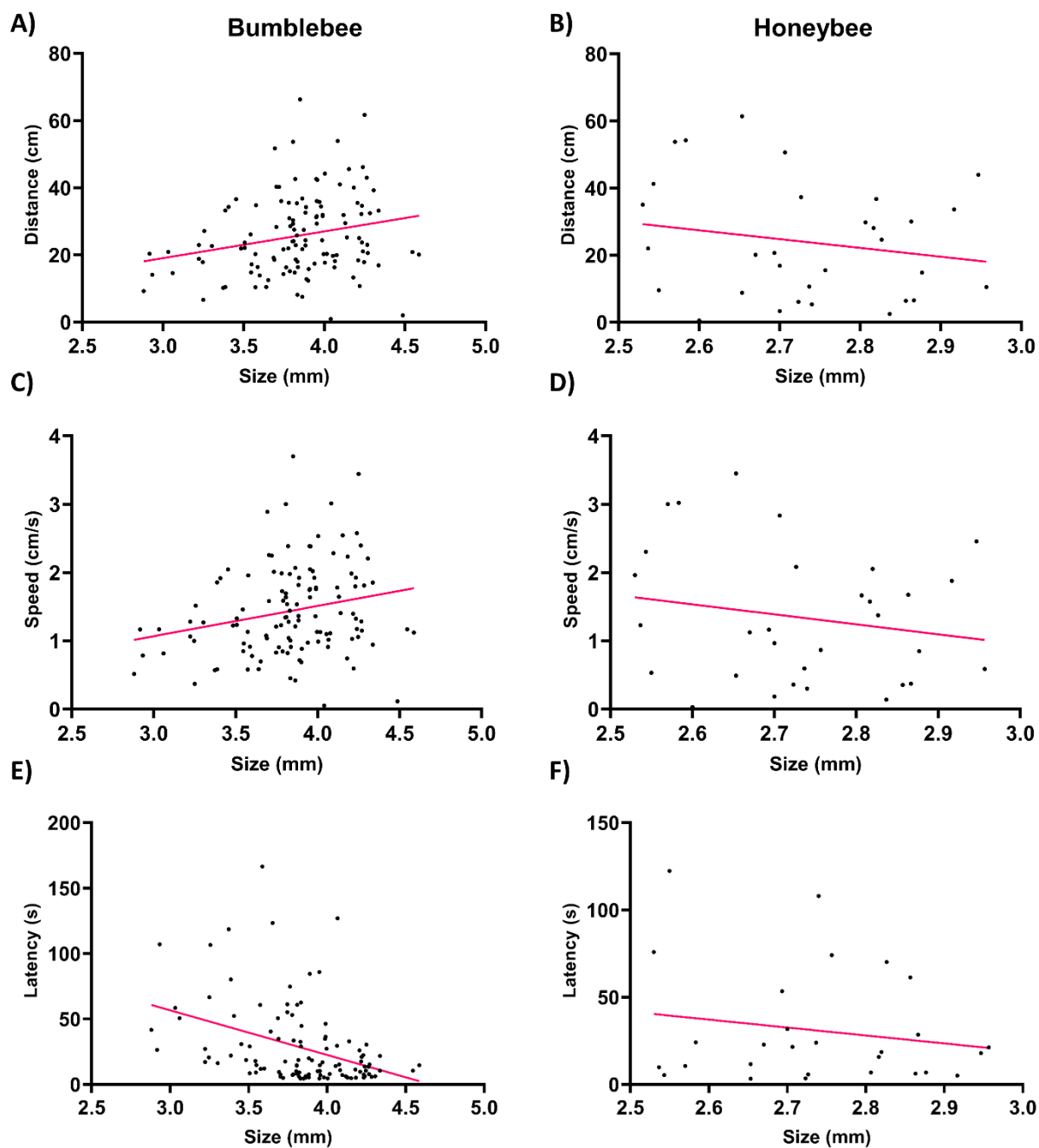

5163

5164 **Figure 9. Impact of insect's size on the motor and temporal performances of the bees during the**  
 5165 **test.** After the last trial we measured the inter wing distance for each bee, reported here as *Size*. This  
 5166 figure show the various parameter measured during the test, distance walked, speed and latency to  
 5167 choose as a function of insect's size. Each point is a bee and the pink line shows the linear regression.  
 5168 **A C E)** Show bumblebees value ( $N = 123$ ). **B D F)** Show honeybee values ( $N = 31$ ). **A B)** Distance  
 5169 walked. **C D)** Walking speed. **E F)** Latency to make a choice.

5170

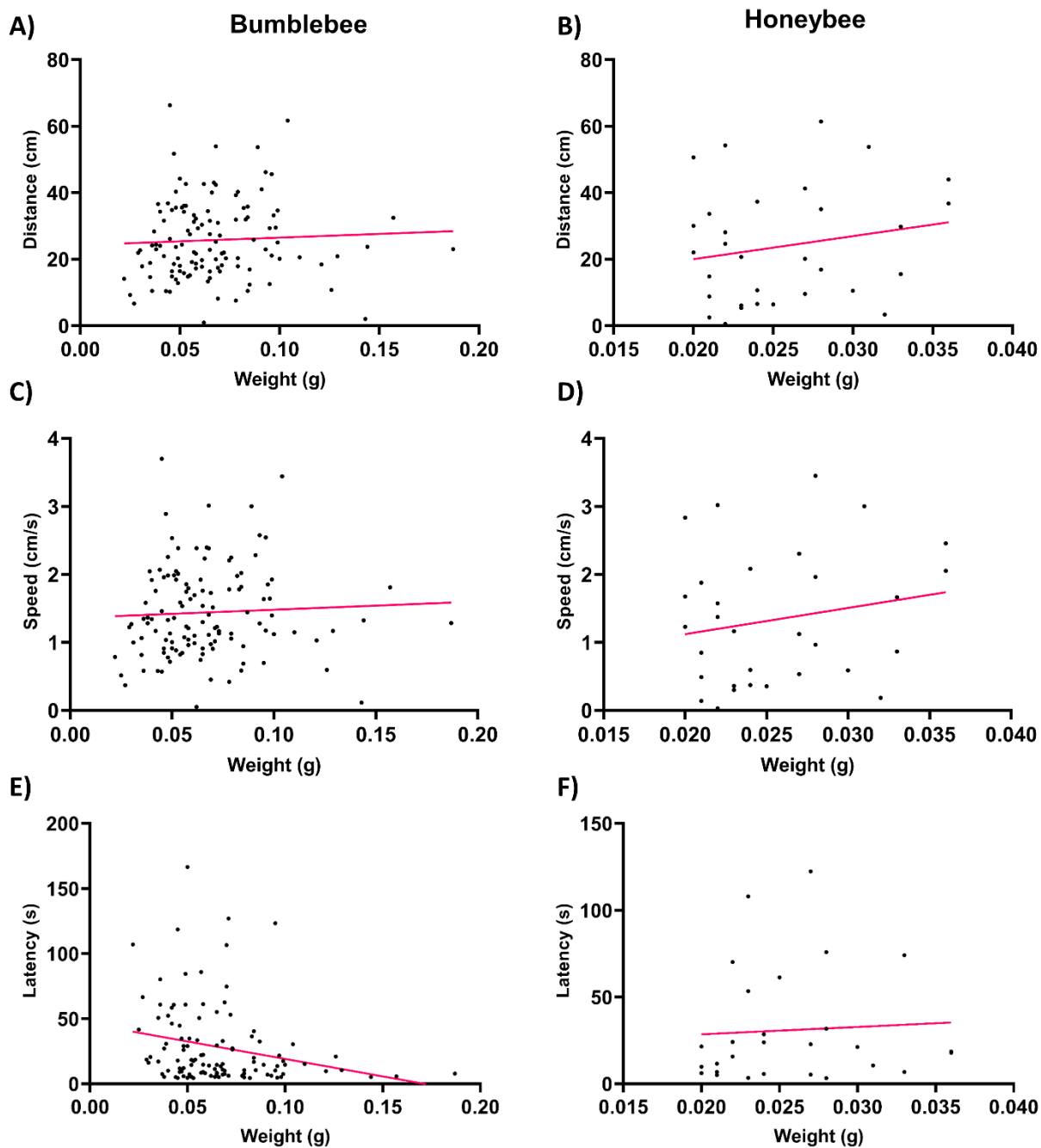

5171

5172 **Figure 10. Impact of insect's weight on the motor and temporal performances of the bees during**  
 5173 **the test.** After the last trial we measured the dry weight of each bee, reported here as *Weight*. This  
 5174 figure show the various parameter measured during the test, distance walked, speed and latency to  
 5175 choose as a function of insect's size. Each point is a bee and the pink line shows the linear regression.  
 5176 **A C E)** Show bumblebees value ( $N = 123$ ). **B D F)** Show honeybee values ( $N = 31$ ). **A B)** Distance  
 5177 walked. **C D)** Walking speed. **E F)** Latency to make a choice.

5178

5179 In order to measure bees learning performance during the conditioning we established a  
 5180 learning score. The learning score is computed as the number of CS+ choices minus the number  
 5181 of CS- choices from the second trial to the test. The size of the bee didn't not significantly affect  
 5182 learning success (Fig. 11A, B; *Bumblebee*:  $F = 8.10^{-4}$ ,  $df:1$ ,  $p = 0.98$ ; *Honeybee*:  $F = 2.0229$ ,  
 5183  $df:1$ ,  $p = 0.17$ ). Heavier honeybees had significantly lower learning scores than lighter ones  
 5184 (Fig. 11D;  $F = 5.3484$ ,  $df:1$ ,  $p = 0.03$ ). However, no effect of weight was visible in bumblebees  
 5185 (Fig. 11C;  $F = 1.125$ ,  $df:1$ ,  $p = 0.291$ ).

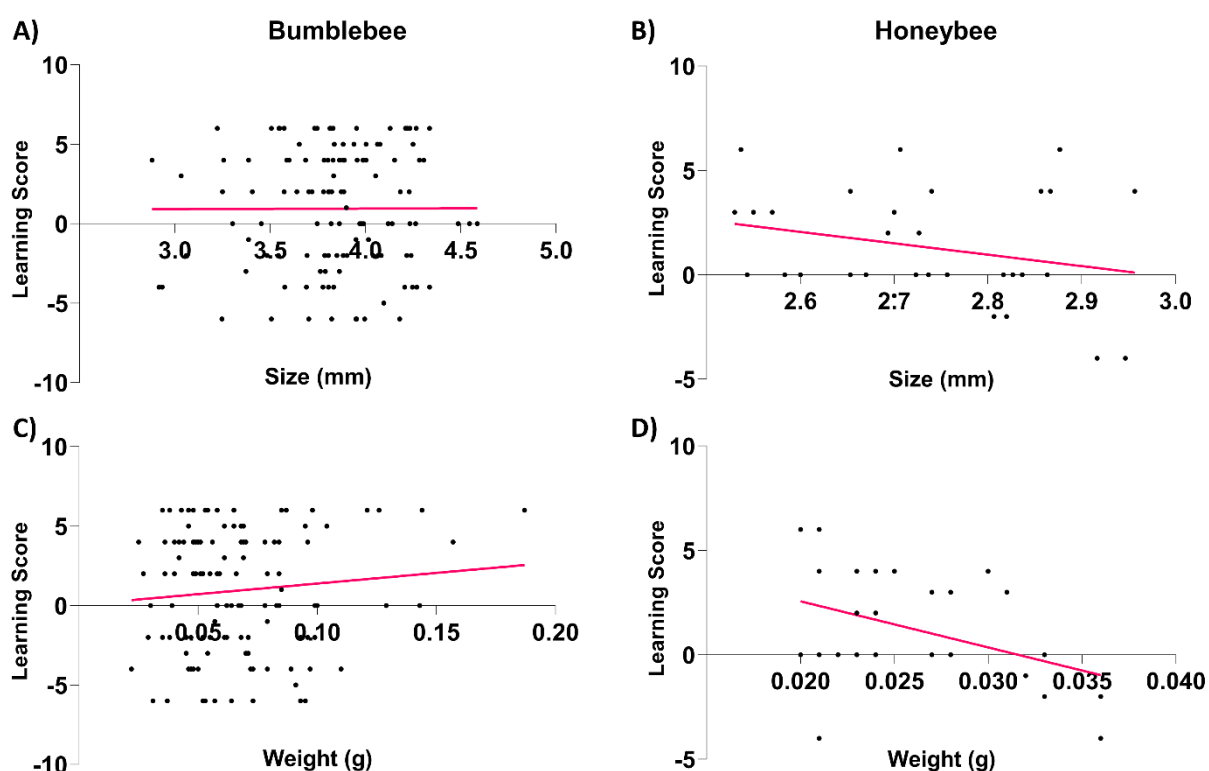

5186

5187 **Figure 11. Impact of insect's dimensions on the learning performances.** Shows learning score as a  
 5188 function of the insect's size (A B) or weight (C D). For each bee we computed the learning score as  
 5189 the difference between the number CS+ and CS- choices from the second trial to the test. Each point  
 5190 represents a bee. The pink line shows the linear regression. A C) Bumblebees ( $N = 123$ ). B D)  
 5191 Honeybees ( $N = 31$ ).

5192

### 5193 Experiment 3: Conditioning bumblebees with Quinine as punishment

5194 In a following experiment we conditioned bumblebees using 1.2 g.L<sup>-1</sup> quinine solution as  
5195 punishment (Dyer and Chittka, 2004). The experiment followed the same protocol from  
5196 experiment 2, 6 trials of maximum 180 s spaced by 60 s inter-trials followed by one non-  
5197 reinforced test. The bumblebees had to discriminate between a blue and a green cylinder, we  
5198 used the colors found in experiment 1, the color of the reward was decided pseudo-randomly,  
5199 green was rewarded as often as blue.

#### 5200 Discrimination learning during training

5201 The evolution of choices across trials was not affected by the color of the reward ( $\chi^2 = 5.566$ ,  
5202 df:2,  $p = 0.62$ ). Therefore, we pooled both rewarded condition together and only shows the  
5203 choices in term of CS+ and CS- irrespective of the color of the cylinders (Fig. 12).

5204 CS+ choices evolved differently from both CS- choices ( $z = -1.458$ ,  $p < 0.00001$ ) and non-  
5205 choices (NC) (Fig. 12A;  $z = 5.223$ ,  $p < 0.00001$ ) as bees learned to respond more to CS+. On  
5206 the other hand, CS- choices did no evolved differently from NCs ( $z = 1.458$ ,  $p = 0.14$ ). In the  
5207 corresponding cumulative heat map (Fig. 12D), a clear V shape is visible, indicating that the  
5208 bees did interact with both sides in the VR and walked towards the cylinders.

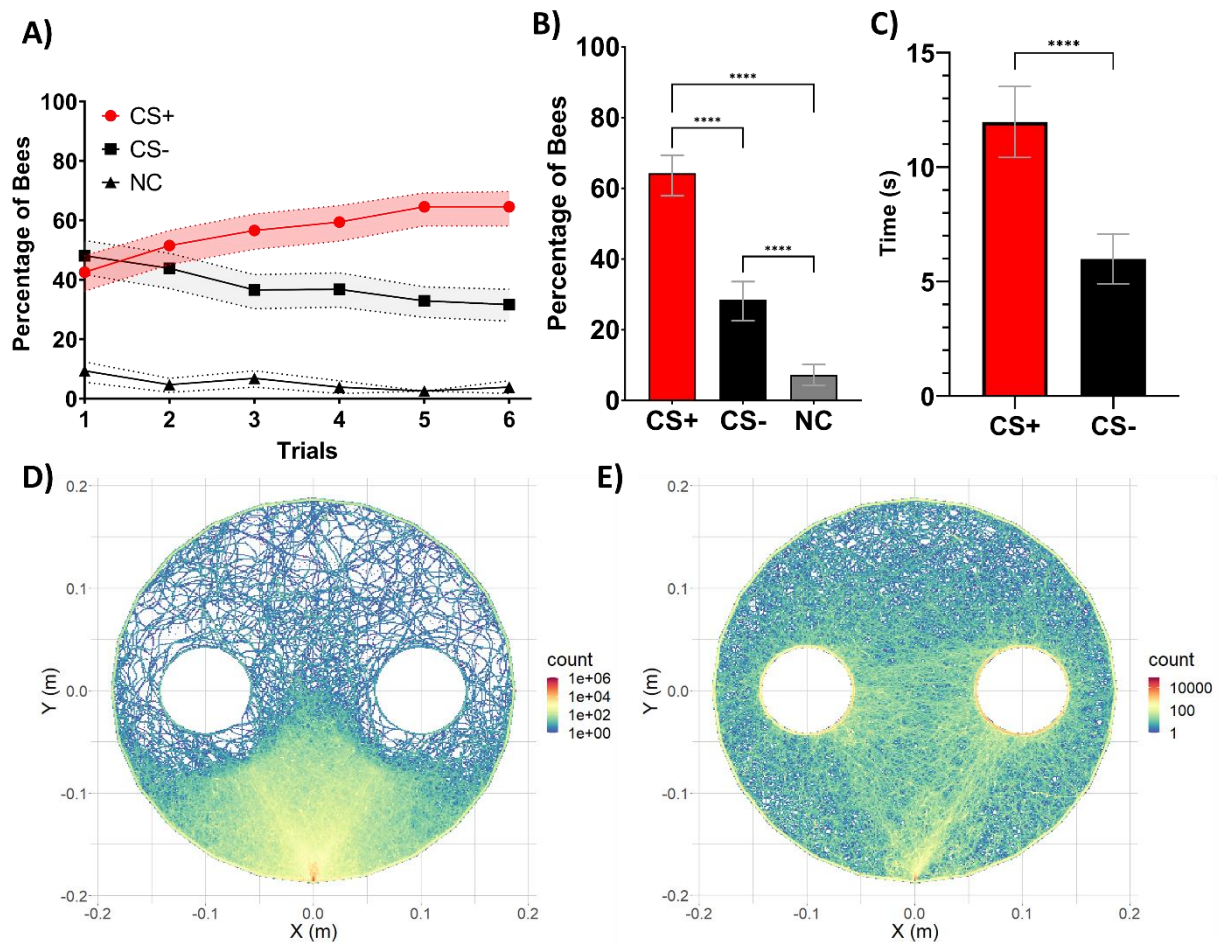

5209

5210 **Figure 12. Test performances (1<sup>st</sup> choice and fixation time) of bumblebees in a color discrimination**  
 5211 **learning task using quinine as negative reinforcement and sucrose as positive.** As there were no  
 5212 significant differences the color conditions (blue or green rewarded), results were pooled ( $N = 235$ ).  
 5213 The graph shows the percentage of bees responding to the CS+ (red), to the CS- (black) or not making  
 5214 any choice (NC; gray) during the training phase (A) and the retention test (B). C) Shows the time spent  
 5215 fixating each stimulus during the test. Error bars indicate 95% confidence intervals. \*:  $p < 0.05$ ; \*\*:  $p <$   
 5216  $0.01$ ; \*\*\*:  $p < 0.001$ ; \*\*\*\*:  $p < 0.0001$ . D) Cumulative heat maps of bumblebees' trajectories during  
 5217 the 6 learning trials ( $N = 235$ ). E) Cumulative heat maps bumblebees' trajectories during the test ( $N =$   
 5218  $235$ ). Warmer color higher density of visits (see color scale).

### 5219 Motor and temporal components of bee trajectories during training

5220 We also analyzed how the trajectory parameters of the bumblebees evolved over trials (Fig.  
 5221 13). The distanced walked decreased significantly across trials (Fig. 13A;  $\chi^2 = 271.62$ ,  $df:1$ ,  $p$   
 5222  $< 0.00001$ ) as bumblebees took more direct routes toward the cylinders. Speed increased  
 5223 significantly with trials (Fig. 13B;  $\chi^2 = 10.076$ ,  $df:1$ ,  $p = 0.0015$ ). This increase was concomitant  
 5224 with an increase in the proportion of bees choosing CS+ (Fig. 12A) and may thus reveal an

5225 augmentation of motivation to reach the reward. Finally, coherent with an increase in speed and  
 5226 a decrease in distance the latency to make a choice decreased significantly across trials (Fig.  
 5227 13C;  $\chi^2 = 90.245$ ,  $df:1$ ,  $p < 0.00001$ ).

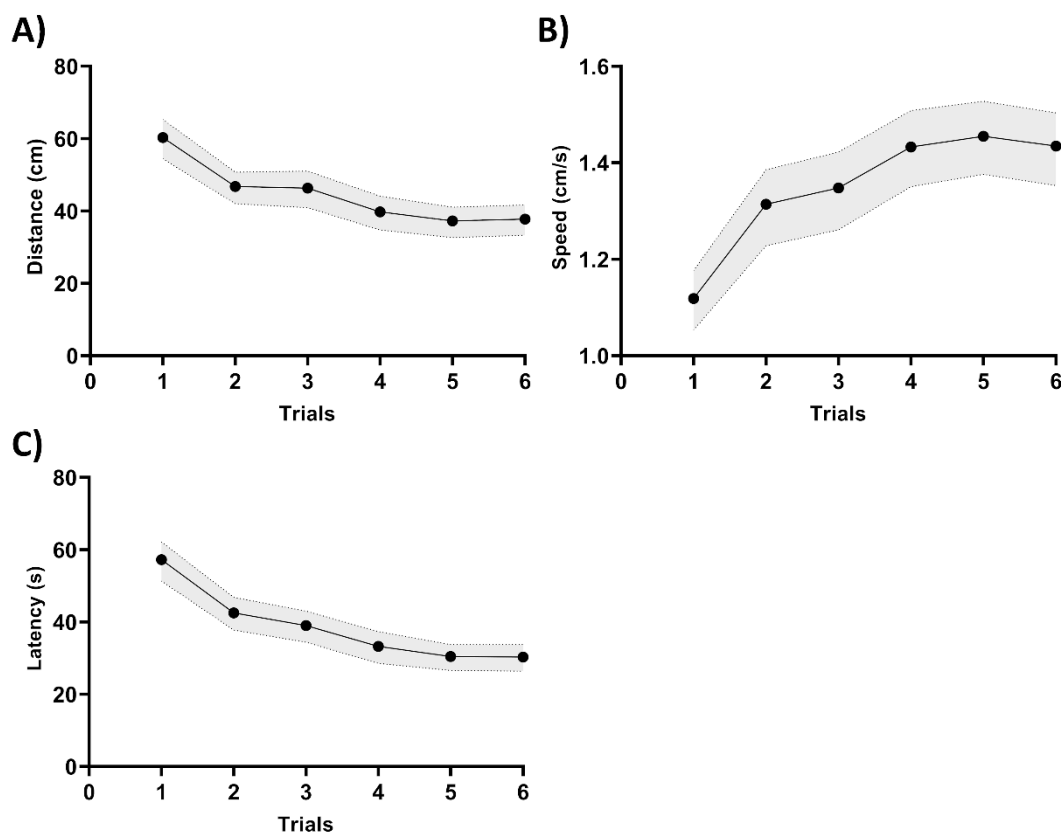

5228  
 5229 **Figure 13. Motor and temporal components of bumblebee trajectories during the acquisition trials.**  
 5230 For both bumblebees conditioned in Experiment 3 ( $N = 235$ ), shows the evolution of **A)** the distance  
 5231 walked, **B)** the walking speed, and **C)** the choice latency during training trials is shown. The dashed  
 5232 lines above and below the curves represent the 95% confidence interval.

### 5233 Test Performance

5234 As in experiment 2, bumblebees were submitted to a test where cylinders were not reinforced.  
 5235 We recorded the percentage of bees choosing correctly the CS+ or the CS- in their first choice,  
 5236 or not choosing (NC) and the time spent fixating the CS+ and the CS- (Fig. 12B).

5237 Bumblebee successfully learned the discrimination as they chose CS+ significantly more than  
 5238 both CS- and NC (Fig. 12B; CS-:  $z = 7.585$ ,  $p < 0.00001$ ; NC:  $z = 10.962$ ,  $p < 0.00001$ ). The

5239 number of NC was also lower than CS- ( $z = 5.621$ ,  $p < 0.00001$ ), suggesting that even bees that  
5240 made the wrong choice were motivated to interact with the VR.

5241 Consistent with their first choice, bumblebees spent more time fixating CS+ than CS- (Fig. 12C;  
5242  $V = 5781$ ,  $p < 0.00001$ ). In the corresponding cumulative heat map (Fig. 12E), we can see that  
5243 bumblebees did interact with both sides and explored both cylinders.

5244

## 5245 Discussion

5246 We have shown that bumblebees are able to solve a color discrimination task in a 3D VR setup.  
5247 After six conditioning trials about 60% of bumblebees were able to correctly chose the rewarded  
5248 stimulus during the non-reinforced test, which is similar to the performances displayed by  
5249 honeybees, both in this study and in previous ones using a comparable protocol (Buatois et al.,  
5250 2017; Lafon et al., 2021). This success rate is however lower than what has been observed in  
5251 visual conditioning of the PER (Riveros and Gronenberg, 2012) where more than 70% of  
5252 bumblebees responded to the rewarded stimulus after seven trials. Walking speed and latency  
5253 to make a choice were also similar between bumblebees and honeybees, confirming the  
5254 suitability of the setup for both species.

5255 When we used NaCl solution as punishment, bees from both species were only able to learn the  
5256 discrimination if the rewarded stimulus was blue. Previous experiment in VR with honeybees  
5257 have shown that NaCl was not always sufficient to produce a conditioned response (Buatois et  
5258 al., 2017). Bumblebees, and honeybees, have an innate preference for short wavelength colors  
5259 like blue (Giurfa et al., 1995; Riveros and Gronenberg, 2012) but we did control in Experiment  
5260 1 that the blue and green used elicited the same level of spontaneous attraction in bumblebees  
5261 (Fig. 3), and the color used for honeybees have been controlled in previous studies (Buatois et  
5262 al., 2017). This result is confirmed by the fact that naïve bees in Experiment 2 did chose as  
5263 much green as blue (Fig. 4A). However, bumblebees have also been shown to learn short  
5264 wavelength colors faster (Gumbert, 2000). Thus, we can speculate that the strength of the NaCl  
5265 reinforcement was not enough to overcome the difference in learning speed between green and  
5266 blue. When conditioned with Quinine, however, bumblebees displayed no color bias and were  
5267 able to solve the discrimination task whether the reward was associated with blue or green, in  
5268 accordance with previous findings where free-flying bumblebees trained to discriminate  
5269 between two perceptually similar colors, one associated with 1.75 M sucrose solution, and the

5270 other with water or quinine solution 120 mM, perform better if they experience quinine on the  
5271 CS- targets rather than water (Chittka et al., 2003). It is also coherent with previous VR results  
5272 where honeybees were able to solve the discrimination when CS- was associated with quinine,  
5273 but not when it was associated with NaCl (Buatois et al., 2017). In Experiment 3, bumblebees  
5274 also show a significant decrease in both the distance walked and the latency to make a choice  
5275 (*i.e.* approaching and centering a stimulus), confirming that they acquire the task over trials and  
5276 learned to navigate the VR environment.

5277 While learning performances were similar, bumblebees had nevertheless a higher motivation  
5278 than honeybees, as 60% of honeybees did not make enough choices to be kept in the analysis  
5279 against only 11% in bumblebees. Artificially forcing the insect to walk might conflict less with  
5280 the natural ecology of *Bombus terrestris* who lives in underground nests than it does for  
5281 honeybee foragers who spend most of their time in flight. This contrast would have been  
5282 increased further in our study as the honeybees were foragers collected from a feeder in our  
5283 apiary while the bumblebees were collected from their commercial nest box that they had never  
5284 left in their life. Additionally, the analysis of motor parameters revealed that bumblebees walk  
5285 longer distances than honeybees, which was likely due to the bigger size of bumblebees since  
5286 walking distance and speed were positively correlated with size in bumblebees. Thus, it is  
5287 possible that bumblebees had an easier time walking on the treadmill due to their bigger size  
5288 and ecology (Dahmen et al., 2017).

5289 We found no relation between size and learning performances in our experiment. Several  
5290 studies have shown that bigger bumblebees have a better visual acuity than smaller bees  
5291 (Macuda et al., 2001; Spaethe and Chittka, 2003; Wertlen et al., 2008; Taylor et al.,  
5292 2019). Throughout the experiment the cylinders subtended a visual angle of at least 6° at the  
5293 beginning of a trial and up to 53° when making a choice, they were thus always above the  
5294 minimal 5° necessary for color vision in honeybee (Giurfa et al., 1996). It is thus unlikely that

5295 higher visual acuity could help in better solving the discrimination. Larger bumblebees have  
5296 been shown to learn faster in free flight condition (Worden et al., 2005). Larger bumblebees  
5297 also assumes the role of forager for the colony (Goulson, 2003), a role for which they are better  
5298 suited than smaller workers (Heinrich and Heinrich, 1983; Goulson et al., 2002; Spaethe and  
5299 Weidenmüller, 2002; Ings et al., 2005; Klein et al., 2017). So it is possible that the learning  
5300 abilities of larger bumblebees come from their life experience as foragers (Giurfa et al., 2003;  
5301 Cabirol et al., 2017), however in this study all bumblebees were naive as they never left their  
5302 nest box prior to the experiment which would have prevented the bigger workers to improve  
5303 their learning abilities through higher foraging experience. Finally, this is not the first study to  
5304 find no link between size and learning success, in 2008 Raine and Chittka trained free flying  
5305 bumblebees to collect a sucrose rewarded from colored feeders and found no correlation  
5306 between insect size and learning speed (Raine and Chittka, 2008).

5307 On the other hand, we found a negative effect of body weight on honeybee's learning  
5308 performances, it is possible that bees with a higher fat storage had a lower motivation to solve  
5309 the task as foraging is coupled with a reduced rate of fat in this species (Toth et al., 2005; Toth  
5310 and Robinson, 2005). Consequently, fatter bees might have been less experienced young  
5311 foragers, thus explaining relative lower performances.

5312

## 5313 Conclusion

5314 Our results clearly demonstrate the ability of bumblebees to solve a color discrimination task  
5315 under VR condition. While learning performances were similar to those of honeybees,  
5316 bumblebees engaged more with the VR and thus less individuals were discarded because of a  
5317 lack of choices in bumblebees, confirming the suitability of bumblebees as a model for the  
5318 study of visual learning in VR. We found that bumblebees solved the discrimination better when  
5319 the CS- was paired with quinine rather than NaCl. No correlation between bumblebee size and  
5320 learning success was evidenced which might suggest that the better learning success observed  
5321 in larger bumblebees in the literature were linked to a higher foraging experience as the  
5322 bumblebees we tested were all naive. These results, associated with their high resilience, point  
5323 at the bumblebees as a prime candidate to explore the underlying mechanisms of visual learning  
5324 by coupling VR experiments with invasive electrophysiological or calcium imaging studies.

## 5325 Acknowledgements

5326 We thank Mathieu Lihoreau for his help in acquiring and maintaining the bumblebee colonies.  
5327 We also thank Benjamin H. Paffhausen, and Marco Paoli for valuable discussions and support.  
5328 This work was supported by an ERC Advanced Grant ('Cognibrains') to M.G, who also thanks  
5329 the Institut Universitaire de France (IUF), the CNRS and the University Paul Sabatier for  
5330 support.

## 5331 Contributions

5332 The project was conceived by AAW, MG and GL. G.L performed all the behavioral  
5333 experiments. Naïs Judan, Eva Blot, and Karolina Pecharova also assisted with the behavioral  
5334 experiments. Behavioral experiments were supervised by M.G. and A.A.-W. Statistical  
5335 analyses were performed by G.L. The manuscript was written by G.L and was corrected and

5336 discussed by all authors. M. G. obtained the funding necessary for this work. All authors  
5337 reviewed and approved the final version of the manuscript.

5338 **Ethics declarations**

5339 **Competing interests**

5340 The authors declare no competing interests.

5341

5342 **References**

- 5343 Anfora, G., Rigosi, E., Frasnelli, E., Ruga, V., Trona, F., Vallortigara, G., 2011. Lateralization in the  
5344 Invertebrate Brain: Left-Right Asymmetry of Olfaction in Bumble Bee, *Bombus terrestris*. PLOS ONE 6,  
5345 e18903. <https://doi.org/10.1371/journal.pone.0018903>
- 5346 Bates, D., Mächler, M., Bolker, B., Walker, S., 2014. Fitting Linear Mixed-Effects Models using lme4.  
5347 ArXiv14065823 Stat.
- 5348 Bitterman, M.E., Menzel, R., Fietz, A., Schäfer, S., 1983. Classical conditioning of proboscis extension  
5349 in honeybees (*Apis mellifera*). J. Comp. Psychol. Wash. DC 1983 97, 107–119.
- 5350 Buatois, A., Flumian, C., Schultheiss, P., Avarguès-Weber, A., Giurfa, M., 2018. Transfer of Visual  
5351 Learning Between a Virtual and a Real Environment in Honey Bees: The Role of Active Vision. Front.  
5352 Behav. Neurosci. 12, 139. <https://doi.org/10.3389/fnbeh.2018.00139>
- 5353 Buatois, A., Laroche, L., Lafon, G., Avarguès-Weber, A., Giurfa, M., 2020. Higher-order discrimination  
5354 learning by honeybees in a virtual environment. Eur. J. Neurosci. 51, 681–694.  
5355 <https://doi.org/10.1111/ejn.14633>
- 5356 Buatois, A., Pichot, C., Schultheiss, P., Sandoz, J.-C., Lazzari, C.R., Chittka, L., Avarguès-Weber, A.,  
5357 Giurfa, M., 2017. Associative visual learning by tethered bees in a controlled visual environment. Sci.  
5358 Rep. 7. <https://doi.org/10.1038/s41598-017-12631-w>
- 5359 Cabirol, A., Brooks, R., Groh, C., Barron, A.B., Devaud, J.-M., 2017. Experience during early adulthood  
5360 shapes the learning capacities and the number of synaptic boutons in the mushroom bodies of honey  
5361 bees (*Apis mellifera*). Learn. Mem. Cold Spring Harb. N 24, 557–562.  
5362 <https://doi.org/10.1101/lm.045492.117>
- 5363 Chittka, L., Dyer, A.G., Bock, F., Dornhaus, A., 2003. Bees trade off foraging speed for accuracy.  
5364 Nature 424, 388–388. <https://doi.org/10.1038/424388a>
- 5365 Chittka, L., Thomson, J.D., 1997. Sensori-motor learning and its relevance for task specialization in  
5366 bumble bees. Behav. Ecol. Sociobiol. 41, 385–398. <https://doi.org/10.1007/s002650050400>
- 5367 Church, D.L., Plowright, C.M.S., 2006. Spatial encoding by bumblebees (*Bombus impatiens*) of a  
5368 reward within an artificial flower array. Anim. Cogn. 9, 131–140. [https://doi.org/10.1007/s10071-](https://doi.org/10.1007/s10071-005-0011-6)  
5369 005-0011-6
- 5370 Cnaani, J., Thomson, J.D., Papaj, D.R., 2006. Flower Choice and Learning in Foraging Bumblebees:  
5371 Effects of Variation in Nectar Volume and Concentration. Ethology 112, 278–285.  
5372 <https://doi.org/10.1111/j.1439-0310.2006.01174.x>
- 5373 Dahmen, H., Wahl, V.L., Pfeffer, S.E., Mallot, H.A., Wittlinger, M., 2017. Naturalistic path integration  
5374 of *Cataglyphis* desert ants on an air-cushioned lightweight spherical treadmill. J. Exp. Biol. 220, 634–  
5375 644. <https://doi.org/10.1242/jeb.148213>
- 5376 Dukas, R., Waser, N.M., 1994. Categorization of food types enhances foraging performance of  
5377 bumblebees. Anim. Behav. 48, 1001–1006. <https://doi.org/10.1006/anbe.1994.1332>
- 5378 Dyer, A.G., Chittka, L., 2004. Biological significance of distinguishing between similar colours in  
5379 spectrally variable illumination: bumblebees (*Bombus terrestris*) as a case study. J. Comp. Physiol.  
5380 [A] 190, 105–114. <https://doi.org/10.1007/s00359-003-0475-2>

- 5381 Foster, J.J., Sharkey, C.R., Gaworska, A.V.A., Roberts, N.W., Whitney, H.M., Partridge, J.C., 2014.  
5382 Bumblebees learn polarization patterns. *Curr. Biol. CB* 24, 1415–1420.  
5383 <https://doi.org/10.1016/j.cub.2014.05.007>
- 5384 Frasnelli, E., Robert, T., Chow, P.K.Y., Scales, B., Gibson, S., Manning, N., Philippides, A.O., Collett,  
5385 T.S., Hempel de Ibarra, N., 2021. Small and Large Bumblebees Invest Differently when Learning about  
5386 Flowers. *Curr. Biol.* 31, 1058-1064.e3. <https://doi.org/10.1016/j.cub.2020.11.062>
- 5387 Giurfa, M., 2007. Behavioral and neural analysis of associative learning in the honeybee: a taste from  
5388 the magic well. *J. Comp. Physiol. A Neuroethol. Sens. Neural. Behav. Physiol.* 193, 801–824.  
5389 <https://doi.org/10.1007/s00359-007-0235-9>
- 5390 Giurfa, M., Núñez, J., Chittka, L., Menzel, R., 1995. Colour preferences of flower-naive honeybees. *J.*  
5391 *Comp. Physiol. A* 177, 247–259. <https://doi.org/10.1007/BF00192415>
- 5392 Giurfa, M., Sandoz, J.-C., 2012. Invertebrate learning and memory: Fifty years of olfactory  
5393 conditioning of the proboscis extension response in honeybees. *Learn. Mem.* 19, 54–66.  
5394 <https://doi.org/10.1101/lm.024711.111>
- 5395 Giurfa, M., Schubert, M., Reisenman, C., Gerber, B., Lachnit, H., 2003. The effect of cumulative  
5396 experience on the use of elemental and configural visual discrimination strategies in honeybees.  
5397 *Behav. Brain Res.* 145, 161–169. [https://doi.org/10.1016/S0166-4328\(03\)00104-9](https://doi.org/10.1016/S0166-4328(03)00104-9)
- 5398 Giurfa, M., Vorobyev, M., Kevan, P., Menzel, R., 1996. Detection of coloured stimuli by honeybees:  
5399 Minimum visual angles and receptor specific contrasts. *J. Comp. Physiol. [A]* 178, 699–709.  
5400 <https://doi.org/10.1007/BF00227381>
- 5401 Goulson, D., 2003. *Bumblebees: Their Behaviour and Ecology*. Oxford University Press.
- 5402 Goulson, D., Peat, J., Stout, J.C., Tucker, J., Darvill, B., Derwent, L.C., Hughes, W.O.H., 2002. Can  
5403 alloethism in workers of the bumblebee, *Bombus terrestris*, be explained in terms of foraging  
5404 efficiency? *Anim. Behav.* 64, 123–130. <https://doi.org/10.1006/anbe.2002.3041>
- 5405 Gumbert, A., 2000. Color choices by bumble bees (*Bombus terrestris*): innate preferences and  
5406 generalization after learning. *Behav. Ecol. Sociobiol.* 48, 36–43.  
5407 <https://doi.org/10.1007/s002650000213>
- 5408 Heinrich, B., Heinrich, M.J.E., 1983. Heterothermia in Foraging Workers and Drones of the  
5409 Bumblebee *Bombus terrestris*. *Physiol. Zool.* 56, 563–567.  
5410 <https://doi.org/10.1086/physzool.56.4.30155879>
- 5411 Heinrich, B., Mudge, P.R., Deringis, P.G., 1977. Laboratory Analysis of Flower Constancy in Foraging  
5412 Bumblebees: *Bombus ternarius* and *B. terrestris*. *Behav. Ecol. Sociobiol.* 2, 247–265.
- 5413 Ings, T.C., Schikora, J., Chittka, L., 2005. Bumblebees, humble pollinators or assiduous invaders? A  
5414 population comparison of foraging performance in *Bombus terrestris*. *Oecologia* 144, 508–516.  
5415 <https://doi.org/10.1007/s00442-005-0081-9>
- 5416 Keasar, T., Motro, U., Shur, Y., Shmida, A., 1996. Overnight memory retention of foraging skills by  
5417 bumblebees is imperfect. *Anim. Behav.* 52, 95–104. <https://doi.org/10.1006/anbe.1996.0155>
- 5418 Klein, S., Pasquaretta, C., Barron, A.B., Devaud, J.-M., Lihoreau, M., 2017. Inter-individual variability in  
5419 the foraging behaviour of traplining bumblebees. *Sci. Rep.* 7, 4561. <https://doi.org/10.1038/s41598-017-04919-8>  
5420

- 5421 Kulahci, I.G., Dornhaus, A., Papaj, D.R., 2008. Multimodal signals enhance decision making in foraging  
5422 bumble-bees. *Proc. R. Soc. B Biol. Sci.* 275, 797–802. <https://doi.org/10.1098/rspb.2007.1176>
- 5423 Lafon, G., Howard, S.R., Paffhausen, B.H., Avarguès-Weber, A., Giurfa, M., 2021. Motion cues from  
5424 the background influence associative color learning of honey bees in a virtual-reality scenario. *Sci.*  
5425 *Rep.* 11, 21127. <https://doi.org/10.1038/s41598-021-00630-x>
- 5426 Lavery, T.M., 1994. Bumble bee learning and flower morphology. *Anim. Behav.* 47, 531–545.  
5427 <https://doi.org/10.1006/anbe.1994.1077>
- 5428 Leadbeater, E., Chittka, L., 2007. The dynamics of social learning in an insect model, the bumblebee  
5429 (*Bombus terrestris*). *Behav. Ecol. Sociobiol.* 61, 1789–1796. [https://doi.org/10.1007/s00265-007-](https://doi.org/10.1007/s00265-007-0412-4)  
5430 0412-4
- 5431 Leadbeater, E., Chittka, L., 2005. A new mode of information transfer in foraging bumblebees? *Curr.*  
5432 *Biol. CB* 15, R447-448. <https://doi.org/10.1016/j.cub.2005.06.011>
- 5433 Leonard, A.S., Dornhaus, A., Papaj, D.R., 2011. Flowers help bees cope with uncertainty: signal  
5434 detection and the function of floral complexity. *J. Exp. Biol.* 214, 113–121.  
5435 <https://doi.org/10.1242/jeb.047407>
- 5436 Li, L., Su, S., Perry, C.J., Elphick, M.R., Chittka, L., Søvik, E., 2018. Large-scale transcriptome changes in  
5437 the process of long-term visual memory formation in the bumblebee, *Bombus terrestris*. *Sci. Rep.* 8,  
5438 534. <https://doi.org/10.1038/s41598-017-18836-3>
- 5439 Lichtenstein, L., Sommerlandt, F.M.J., Spaethe, J., 2015. Dumb and Lazy? A Comparison of Color  
5440 Learning and Memory Retrieval in Drones and Workers of the Buff-Tailed Bumblebee, *Bombus*  
5441 *terrestris*, by Means of PER Conditioning. *PLOS ONE* 10, e0134248.  
5442 <https://doi.org/10.1371/journal.pone.0134248>
- 5443 Lihoreau, M., Raine, N.E., Reynolds, A.M., Stelzer, R.J., Lim, K.S., Smith, A.D., Osborne, J.L., Chittka, L.,  
5444 2013. Unravelling the mechanisms of trapline foraging in bees. *Commun. Integr. Biol.* 6, e22701.  
5445 <https://doi.org/10.4161/cib.22701>
- 5446 Macuda, T., Gegear, R., Lavery, T., Timney, B., 2001. Behavioural assessment of visual acuity in  
5447 bumblebees (*Bombus impatiens*). *J. Exp. Biol.* 204, 559–564. <https://doi.org/10.1242/jeb.204.3.559>
- 5448 Mertes, M., Carcaud, J., Sandoz, J.-C., 2021. Olfactory coding in the antennal lobe of the bumble bee  
5449 *Bombus terrestris*. *Sci. Rep.* 11, 10947. <https://doi.org/10.1038/s41598-021-90400-6>
- 5450 Mertes, M., Dittmar, L., Egelhaaf, M., Boeddeker, N., 2014. Visual motion-sensitive neurons in the  
5451 bumblebee brain convey information about landmarks during a navigational task. *Front. Behav.*  
5452 *Neurosci.* 8.
- 5453 Muth, F., Breslow, P.R., Masek, P., Leonard, A.S., 2018. A pollen fatty acid enhances learning and  
5454 survival in bumblebees. *Behav. Ecol.* 29, 1371–1379. <https://doi.org/10.1093/beheco/ary111>
- 5455 Paulk, A.C., Gronenberg, W., 2008. Higher order visual input to the mushroom bodies in the bee,  
5456 *Bombus impatiens*. *Arthropod Struct. Dev.* 37, 443–458. <https://doi.org/10.1016/j.asd.2008.03.002>
- 5457 Paulk, A.C., Phillips-Portillo, J., Dacks, A.M., Fellous, J.-M., Gronenberg, W., 2008. The processing of  
5458 color, motion, and stimulus timing are anatomically segregated in the bumblebee brain. *J. Neurosci.*  
5459 *Off. J. Soc. Neurosci.* 28, 6319–6332. <https://doi.org/10.1523/JNEUROSCI.1196-08.2008>

- 5460 R Core Team, 2020. R Development Core team (2020). R: A language and environment for statistical  
5461 computing. Vienna, Austria.
- 5462 Raine, N.E., Chittka, L., 2008. The correlation of learning speed and natural foraging success in  
5463 bumble-bees. *Proc. R. Soc. B Biol. Sci.* 275, 803–808. <https://doi.org/10.1098/rspb.2007.1652>
- 5464 Real, L.A., 1992. Information Processing and the Evolutionary Ecology of Cognitive Architecture. *Am.*  
5465 *Nat.* 140, S108–S145. <https://doi.org/10.1086/285399>
- 5466 Riddell, C.E., Mallon, E.B., 2006. Insect psychoneuroimmunology: Immune response reduces learning  
5467 in protein starved bumblebees (*Bombus terrestris*). *Brain. Behav. Immun.* 20, 135–138.  
5468 <https://doi.org/10.1016/j.bbi.2005.06.008>
- 5469 Riveros, A. J., Gronenberg, W., 2009. Learning from learning and memory in bumblebees. *Commun.*  
5470 *Integr. Biol.* 2, 437–440.
- 5471 Riveros, A.J., Gronenberg, W., 2012. Decision-making and associative color learning in harnessed  
5472 bumblebees (*Bombus impatiens*). *Anim. Cogn.* 15, 1183–1193. <https://doi.org/10.1007/s10071-012-0542-6>
- 5474 Riveros, Andre J., Gronenberg, W., 2009. Olfactory learning and memory in the bumblebee *Bombus*  
5475 *occidentalis*. *Naturwissenschaften* 96, 851–856. <https://doi.org/10.1007/s00114-009-0532-y>
- 5476 Riveros, A.J., Leonard, A.S., Gronenberg, W., Papaj, D.R., 2020. Learning of bimodal versus unimodal  
5477 signals in restrained bumble bees. *J. Exp. Biol.* 223, jeb220103. <https://doi.org/10.1242/jeb.220103>
- 5478 Robert, T., Frasnelli, E., Hempel de Ibarra, N., Collett, T.S., 2018. Variations on a theme: bumblebee  
5479 learning flights from the nest and from flowers. *J. Exp. Biol.* 221, jeb172601.  
5480 <https://doi.org/10.1242/jeb.172601>
- 5481 Rusanen, J., Vähäkainu, A., Weckström, M., Arikawa, K., 2017. Characterization of the first-order  
5482 visual interneurons in the visual system of the bumblebee (*Bombus terrestris*). *J. Comp. Physiol. A*  
5483 203, 903–913. <https://doi.org/10.1007/s00359-017-1201-9>
- 5484 Saleh, N., Chittka, L., 2007. Traplining in bumblebees (*Bombus impatiens*): a foraging strategy's  
5485 ontogeny and the importance of spatial reference memory in short-range foraging. *Oecologia* 151,  
5486 719–730. <https://doi.org/10.1007/s00442-006-0607-9>
- 5487 Skorupski, P., Chittka, L., 2010a. Photoreceptor Spectral Sensitivity in the Bumblebee, *Bombus*  
5488 *impatiens* (Hymenoptera: Apidae). *PLOS ONE* 5, e12049.  
5489 <https://doi.org/10.1371/journal.pone.0012049>
- 5490 Skorupski, P., Chittka, L., 2010b. Differences in Photoreceptor Processing Speed for Chromatic and  
5491 Achromatic Vision in the Bumblebee, *Bombus terrestris*. *J. Neurosci.* 30, 3896–3903.  
5492 <https://doi.org/10.1523/JNEUROSCI.5700-09.2010>
- 5493 Skorupski, P., Döring, T.F., Chittka, L., 2007. Photoreceptor spectral sensitivity in island and mainland  
5494 populations of the bumblebee, *Bombus terrestris*. *J. Comp. Physiol. A* 193, 485–494.  
5495 <https://doi.org/10.1007/s00359-006-0206-6>
- 5496 Spaethe, J., Brockmann, A., Halbig, C., Tautz, J., 2007. Size determines antennal sensitivity and  
5497 behavioral threshold to odors in bumblebee workers. *Naturwissenschaften* 94, 733–739.  
5498 <https://doi.org/10.1007/s00114-007-0251-1>

- 5499 Spaethe, J., Chittka, L., 2003. Interindividual variation of eye optics and single object resolution in  
5500 bumblebees. *J. Exp. Biol.* 206, 3447–3453. <https://doi.org/10.1242/jeb.00570>
- 5501 Spaethe, J., Weidenmüller, A., 2002. Size variation and foraging rate in bumblebees (*Bombus*  
5502 *terrestris*). *Insectes Sociaux* 49, 142–146. <https://doi.org/10.1007/s00040-002-8293-z>
- 5503 Taylor, G.J., Tichit, P., Schmidt, M.D., Bodey, A.J., Rau, C., Baird, E., 2019. Bumblebee visual allometry  
5504 results in locally improved resolution and globally improved sensitivity. *eLife* 8, e40613.  
5505 <https://doi.org/10.7554/eLife.40613>
- 5506 Toda, N.R.T., Song, J., Nieh, J.C., 2009. Bumblebees exhibit the memory spacing effect.  
5507 *Naturwissenschaften* 96, 1185–1191.
- 5508 Toth, A.L., Kantarovich, S., Meisel, A.F., Robinson, G.E., 2005. Nutritional status influences socially  
5509 regulated foraging ontogeny in honey bees. *J. Exp. Biol.* 208, 4641–4649.  
5510 <https://doi.org/10.1242/jeb.01956>
- 5511 Toth, A.L., Robinson, G.E., 2005. Worker nutrition and division of labour in honeybees. *Anim. Behav.*  
5512 69, 427–435. <https://doi.org/10.1016/j.anbehav.2004.03.017>
- 5513 Vähäkainu, A., Vähäsöyrinki, M., Weckström, M., 2013. Membrane filtering properties of the  
5514 bumblebee (*Bombus terrestris*) photoreceptors across three spectral classes. *J. Comp. Physiol. A* 199,  
5515 629–639. <https://doi.org/10.1007/s00359-013-0814-x>
- 5516 Wertlen, A.M., Niggebrügge, C., Vorobyev, M., Hempel de Ibarra, N., 2008. Detection of patches of  
5517 coloured discs by bees. *J. Exp. Biol.* 211, 2101–2104. <https://doi.org/10.1242/jeb.014571>
- 5518 Worden, B.D., Skemp, A.K., Papaj, D.R., 2005. Learning in two contexts: the effects of interference  
5519 and body size in bumblebees. *J. Exp. Biol.* 208, 2045–2053. <https://doi.org/10.1242/jeb.01582>
- 5520

5521

## **General Discussion**

5522

## 5523 [General discussion](#)

5524 With this PhD work, we aimed at improving an existing VR set-up in order to overcome the  
5525 impossibility of accessing the nervous system of flying bees solving visual problems. In the  
5526 pursuit of this goal we established a new 3D VR and showed that increasing the complexity of  
5527 the virtual background is detrimental to successful conditioning, as the presence of frontal  
5528 background motion cues impaired the bees' performance in color discrimination learning. We  
5529 then used that VR to condition honeybees in a controlled visual environment which was a  
5530 prerequisite to quantify variation in IEGs expression specific to visual learning. This revealed  
5531 an implication of the optic lobes and the calyces of the mushroom bodies in visual learning, and  
5532 that solving a color discrimination task in 2D and 3D involved different neural mechanisms as  
5533 both modes lead to different pattern of IEG expression. Finally, we showed that bumblebees  
5534 would be an ideal alternative model for future VR experiments, since they are easier to  
5535 condition in high numbers than honeybees, while being probably more robust to invasive brain  
5536 recording techniques.

## 5537 [Virtual reality: progress, limitations and future developments](#)

5538 The first chapter of this thesis represents the first publication of a fully 3D virtual setup showing  
5539 visual learning in harnessed honeybees. Zwaka et al did publish a setup where the colored  
5540 stimuli, a blue and yellow colored stripped, could grow larger as the insect walked toward them  
5541 in 2019. But the behavioral results don't show clearly whether or not the bees managed to learn  
5542 the color discrimination. Their setup also included gray stripes of different heights in the  
5543 background, simulating a far-distant skyline, which might have interfered with color learning  
5544 as our work showed. Our setup has several advantages over previous attempts. First we paid  
5545 more attention to the weight of the treadmill, using a smaller and lighter treadmill of 5cm for  
5546 1g which were thus easier to mobilize for the bees and resulted in a more natural behavior. This  
5547 is an improvement on previous setups that used a 10 cm Styrofoam ball (Buatois et al., 2017,

5548 2018; Zwaka et al., 2019; Buatois et al., 2020) which would have had a weight of about 7.8g  
5549 and thus require from the bee 31 time the force required to move itself on a flat surface  
5550 compared to only 5 time in our current setup (Dahmen et al., 2017). We recently acquired  
5551 specially made hollow balls that might allow to drive that number further down. Our VR  
5552 software is based on a video game engine (Unity) which offers two main advantages. First, they  
5553 have been the focus of intense optimization work in the past decades to reduce as much as  
5554 possible the latency between player input and reaction from the software, thus in our current  
5555 implementation we measured a latency of  $18.00 \pm 2.53$  ms between a movement of the ball and  
5556 a reaction in the VR. Keeping the latency as low as possible is very important to create a  
5557 believable illusion as honeybee vision has a very high temporal resolution (Srinivasan and  
5558 Lehrer, 1984). Second, video game engines offer a wide set of tools that make maintaining and  
5559 expanding the possibilities of our VR software easier. We have made our software open source  
5560 (<https://github.com/G-Lafon/BeeVR>) which should provide a simple and adaptable solution to  
5561 support a variety a conditioning protocol. Moreover, this gives us the opportunity to keep  
5562 growing its possibilities outside of our own projects by allowing other teams to contribute the  
5563 functionality they need in their work.

5564 In chapter one, we focused on investigating the influence of motion cues, both frontal and  
5565 ventral, on associative color learning in VR. By enriching the VR with a background producing  
5566 optic flow we were expecting to improve bees' performances as optic flow has been shown to  
5567 be crucial for flight navigation in bees (Baird et al., 2006; Frasnelli et al., 2018; Baird et al.,  
5568 2021), as well as to improve visual learning in harnessed condition (Balamurali et al., 2015). It  
5569 was thus surprising to find that motion cues from the background of the VR impaired color  
5570 discrimination of objects located in the virtual foreground. Indeed, only when the background  
5571 was empty were the bees able to properly learn the discrimination. However, in the condition  
5572 where optic flow from the background was artificially suppressed, by fixing the grating to the

5573 bee's gaze, honeybees spend more time fixating the rewarded object during the non-rewarded  
5574 test, despite not showing a clear preference in term of first choices, which suggest a learning  
5575 effect albeit less strong than in the empty background condition. Suppressing motion cues  
5576 allowed thus to rescue some learning abilities, suggesting that both the motion cues emanating  
5577 from the background, and its illumination conditions, may have interfered with color learning  
5578 in the VR arena. To explain this effect, we hypothesized that both the luminosity and motion  
5579 cues from the background might have distracted the insects by decreasing their attention toward  
5580 the objects of interest. By contrast ventral motion cues had no effect on color learning  
5581 performances, in concordance with our previous conclusions as the ventral motion cues  
5582 emerged from painted dots on the treadmill and provided thus no additional distracting  
5583 luminosity while they were not competing spatially with the colored cuboids. However, ventral  
5584 motion cues did affect the walking speed of bees. Honeybees were walking slower when the  
5585 treadmill motion was generating more optic flow. We know that ventral optic flow is a measure  
5586 of distance for flying bees, these results thus suggest that bees also use it to evaluate walked  
5587 distances.

5588 In the introduction we claimed that the existing VR setup were not at the level of efficiency of  
5589 PER to trigger learning in bees as the associated learning rate is slower. Unfortunately,  
5590 increasing the complexity of the VR by introducing a richer background did not prove to be a  
5591 solution to improve learning performances in VR. So, if enriching the VR is not a solution,  
5592 what options are left to improve learning rates in VR?

5593 A few technical improvements are still possible: replacing the video projector with a panel of  
5594 LEDs to increase the refresh rate beyond 200 Hz (limit of the bee's eye temporal resolution),  
5595 and reducing the weight of the ball even further by using hollow Styrofoam ball. We could also  
5596 introduce an automatized reward system, as was done in Zwaka et al. 2019, to increase  
5597 consistency in reward delivery and the experimental productivity by running several

5598 replications in parallel due to a full automatization of the setup. However, concerning the virtual  
5599 environment itself, it seems that we have reached the limit of what can be achieved as making  
5600 the virtual world more complex reduced performances (chapter 1) while moving from 2D to  
5601 3D did not improve learning performances (chapter 3), where the same setup with 2D VR, lead  
5602 to the same 58% of correct choices during the test. Thus, contrary to our expectations, increased  
5603 complexity does not produce better results. In the context of visual learning, the future  
5604 development of VR should hence focus on actually making the VR simpler. It might not  
5605 improve learning performances but we now know that it will not impede them, and it will get  
5606 us closer to an equivalent of PER for the exploration of visual learning with a simple and easily  
5607 reproducible setup that can be used by many teams at little cost.

5608 Now that we've established functioning protocols for differential learning in VR (chapter 1 and  
5609 2) (Buatois et al., 2017; Lafon et al., 2021) future developments can focus on adapting protocols  
5610 for more complex learning task like reversal learning, or concept learning. This would open the  
5611 higher-order cognitive abilities of the bees to deeper investigations.

#### 5612 [Investigating the brain regions involved in differential visual learning in VR](#)

5613 In chapter 2, we used the 3D VR environment established in chapter 1 to study visual learning  
5614 and determine if it leads to changes in immediate early gene (IEG) expression in specific areas  
5615 of the bee brain. We focused on 3 IEGs related to bee foraging and orientation, *kakusei*, *Hr38*  
5616 and *Egr1*. This work represents the first controlled experiments on the variations of IEGs level  
5617 in the honeybee brain as a result of visual learning, as previous study focused on foraging and  
5618 orientation flights (Kiya et al., 2007; Lutz and Robinson, 2013; Fujita et al., 2013; Singh et al.,  
5619 2018; Ugajin et al., 2018; Iino et al., 2020). Our experiment revealed an increase in *Egr1*  
5620 expression in the calyces of the mushroom bodies of learners compared to non-learners. Even  
5621 though the implication of mushroom bodies in visual learning in the bee is expected given the  
5622 crucial role of mushroom bodies for the acquisition, storage and retrieval of olfactory memories

5623 (Menzel, 1999, 2014; Devaud et al., 2015) and the parallels between visual and olfactory inputs  
5624 at the level of the calyces, studies addressing the role of mushroom bodies in honey bee visual  
5625 learning and memory remain rare. This finding is coherent with previous results that found an  
5626 increase in the dopaminergic receptor gene *Amdop1* in the calyces of the mushroom bodies as  
5627 a result of aversive visual learning (Marchal et al., 2019). The fact that we found no visual  
5628 learning induced variations of *kakusei* despite reports of enhanced expression in foragers or in  
5629 orienting bees (Kiya et al., 2007; Kiya and Kubo, 2010; Ugajin et al., 2018) suggests that the  
5630 expression is not necessarily related to learning occurring in these contexts.

5631 We did not find any variation of expression in the central brain despite previous studies  
5632 suggesting a role of the CX in visual learning (Plath et al., 2017). This could be due to the  
5633 limited spatial resolution of our brain dissection. Indeed, our current technique did not allow us  
5634 to isolate the CX from adjacent structures, mainly the subesophageal zone and the peduncle of  
5635 the mushroom bodies. It is possible that variations in the CX got diluted by unspecific responses  
5636 from the adjacent structures that got included in the dissection. Future experiments would  
5637 benefit from more precise dissections using, for example, Laser-Capture Microdissection that  
5638 would allow dissection at cellular resolution. Higher spatial resolution could also allow to  
5639 investigate other sub regions of the brain, as previous studies suggested a role of the medial  
5640 lobes of the mushroom bodies in visual learning (Plath et al., 2017) for example.

5641 IEGs are transcribed transiently and rapidly in response to specific stimulations inducing neural  
5642 activity without de novo protein synthesis (Bahrami and Drabløs, 2016), since their expression  
5643 is part of the early stages of the cell response to an external stimulus, the quantification of IEGs  
5644 expression level is a good proxy for cell activity. On the other hand, since they are at such an  
5645 early stage of the cell response, they integrate signals from many different inputs. This means  
5646 that in order to control the specificity of the measured response, the inputs must be tightly  
5647 controlled. This is where VR was important, since it allows to completely control the visual

5648 inputs presented to the insect during the conditioning. We can thus make sure that all bees had  
5649 the same visual experience and that the difference observed between learners and non-learners  
5650 is specific of the learning and not caused by a difference in sensory input.

5651 The data from chapter 2 confirmed that the mushroom bodies are involved in visual learning  
5652 and show that virtual reality can be successfully used to investigate the neural mechanism of  
5653 visual learning. However, the analysis here was done *ex-vivo* after the conditioning. In order to  
5654 go further it would be interesting to be able to perform live recordings from the bees as they  
5655 learn. We know from previous works that it is possible to record electrophysiological activity  
5656 from behaving bees in VR (Paulk et al., 2014; Zwaka et al., 2019; Rusch et al., 2021). Coupling  
5657 our VR setup with electrophysiological recordings thus appear like a logical next step.

5658 In the third chapter we reproduced the previous experiment but using a simpler, more restrictive  
5659 2D VR. Surprisingly we found a different pattern of activation by comparison with the 3D VR  
5660 despite the fact that the conditioning protocol and the stimuli used were similar.

5661 We showed that, in 2D conditions, associative color learning led to a downregulation of the  
5662 three IEGs considered in different areas of the visual circuit in the learner group compared to  
5663 the non-learners. While *Egr1* was downregulated in the optic lobes, *Hr38* and *kakusei* were  
5664 coincidentally downregulated in the MB calyces. This was doubly unexpected because results in  
5665 3D showed an upregulation instead, but also because increased neural activity resulting from  
5666 experience-dependent phenomena is usually reflected by an upregulation of IEG expression  
5667 (Bahrami and Drabløs, 2016). The downregulation suggests an inhibition of neural activity in  
5668 key areas involved in visual processing— optic lobes and mushroom bodies - of the learner  
5669 group.

5670 Inhibition of the optic lobes, suggested by the downregulation of *Egr1* in that region, is coherent  
5671 with the multiple GABAergic fibers innervating the medulla and lobula (Schäfer and Bicker,

5672 1986) and with the increase in *Amgad* expression, the gene coding for a key enzyme of the  
5673 GABA synthesis, in the optic lobes in foragers (Kiya and Kubo, 2010). In the MB neural  
5674 inhibition is provided by GABAergic feedback neurons (Av3 neurons) (Rybak and Menzel,  
5675 1993), which are responsible for the sparse coding responses exhibited by Kenyon cells. These  
5676 neurons have been shown to be involved in negative patterning (Devaud et al., 2015). Inhibition  
5677 at the level of the MBs may therefore be part of certain learning phenomena, which require  
5678 enhanced neural sparseness to de-correlate stimulus representations and thus increase memory  
5679 specificity. Both *kakusei* and *Hr38* downregulation in the MBs in the 2D VR may be the  
5680 consequence of plastic changes in GABAergic signaling in the calyces of the MBs.

5681 Both VR experiments were done under similar handling conditions, used strictly the same  
5682 behavioral criteria and presented the same colors as stimuli. Genetic analyses were also  
5683 performed under the same conditions and using the same materials and methods. The main  
5684 difference comes from the way the bees were able to inspect the stimuli: in 3D, the object were  
5685 cuboids, could be approach from any side and would expand and retract as the bee got closer  
5686 or further away from them; in 2D, the bee could only move the objects laterally and could not  
5687 get closer or further away from them. *Erg1* upregulation in the learner group in the 3D VR  
5688 could thus results from an interaction between an exploratory drive of the environment and  
5689 learning. In 2D VR, GABA-mediated inhibition may act as a gain control mechanism that  
5690 enhances response efficiency and stimulus control. It has indeed been proposed to play a  
5691 fundamental role in establishing selectivity for stimulus orientation and direction of motion in  
5692 mammals (Rose and Blakemore, 1974; Sillito, 1979; Tsumoto et al., 1979). As the latter is  
5693 particularly important in the 2D VR, enhanced GABA inhibition could be associated with  
5694 learning to master the visual discrimination in this context. It is also possible that the two objects  
5695 appear more similar in 2D as the insects have less opportunity to inspect them, it could thus  
5696 require sparse coding that has been shown to be required to discriminate similar odors in flies

5697 (Lin et al., 2014). However, we measured no difference in learning success between 2D and 3D  
5698 which goes against an increased difficulty of the task in 2D. Another possible explanation is a  
5699 possible difference in the visual acquisition mechanisms recruited by these two scenarios. On  
5700 one hand, the 3D experiment might include a navigation component where body movements  
5701 translate into a displacement and a recognizable change in the visual scene, which can then be  
5702 computed against the available internal information about the displacement. While, on the other  
5703 hand, the 2D experiment is closer to a purely operant task where the animal needs to engage in  
5704 two different, but stereotyped motor patterns, turn left or turn right, according to the position of  
5705 CS+ on the screen. The observed differences in IEG expression between the two types of VR  
5706 would then reflect the two different mechanisms used to reach the rewarded stimulus. One  
5707 involving navigation while the other is purely operant.

5708 Taken together chapter 2 and 3 suggest the existence of a distributed memory trace along the  
5709 visual system and highlight the importance of MBs for color learning in bees. They also point  
5710 at the OLs, and the calyces of the MBs as region of interest for further investigation of the  
5711 neural correlates of visual learning.

5712

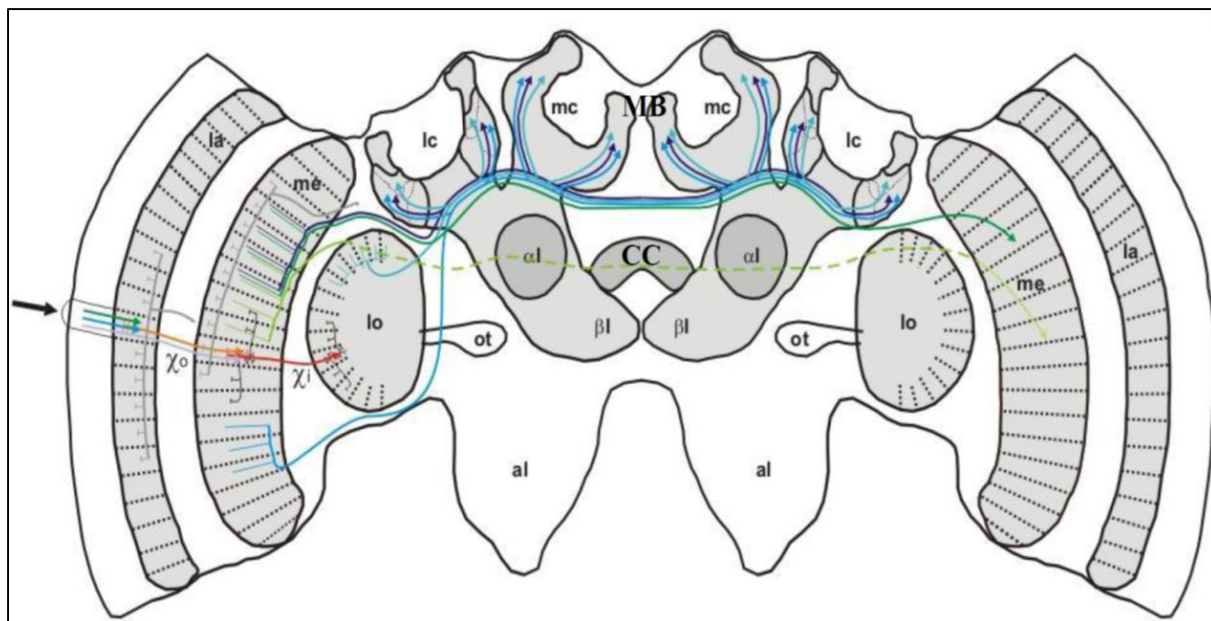

5713

5714 **Figure 1. The different visual neuronal populations and pathways of the honeybee brain.**  
 5715 The black arrow indicates color stimulation. La = lamina,  $\chi_o$  = outer chiasm, me = medulla,  $\chi_i$   
 5716 = inner chiasm, lo = lobula, le = lateral calyx of the mushroom bodies, me = median calyx,  $\alpha$  =  
 5717 alpha-lobe,  $\beta$  = beta-lobe, al = antennal lobe, ot = anterior optic tuberculum. MB: mushrom  
 5718 bodies; CC: central complex. Courtesy of M. Giurfa.

5719 Throughout chapter 2 and 3 we have relied heavily on two terms, *learner* and *non-learner*. We  
 5720 have defined the *learners* as the animals that made the correct choice during the non-rewarded  
 5721 test and the *non-learners* as the rest, meaning those that either chose wrong or did not chose.  
 5722 During the first trial, naive bees have a 40% chance to choose the CS+ in 3D, as measured in  
 5723 the first trials of our 3D experiments (chapter 1) and about 50% in 2D (first trial, chapter 3),  
 5724 meaning that in both situations the probability to randomly be a *learner* is very high. Through  
 5725 the conditioning process the proportion of correct choices in the population increases  
 5726 significantly, meaning that the bees are changing their behavior and are not choosing randomly  
 5727 anymore, they are learning. That's why we still use that classification, because we think it is  
 5728 reasonable to expect that the bees that made a correct choice at the end are the ones that learned  
 5729 the association, since we clearly see that some bees are learning during the conditioning process.  
 5730 But in truth we still have no certitude over who actually learned something and who still chose  
 5731 randomly. By using the first choice as a criterion we know that the *learner* group should contain

5732 more individual that learned something but we can't identify them and guarantee that they all  
5733 actually learned something. First choice and other similar binomial variables are more  
5734 informative about the population than the individuals (Gallistel et al., 2004; Pamir et al., 2011,  
5735 2014). However, in studies like the one in chapter 2 and 3, we need individual information to  
5736 be able to confidently identify the animals that learned the task. Therefore, future studies aiming  
5737 at measuring variations induced by learning in the brain of animal will require more quantitative  
5738 variables like the latency to display the condition response, the stability of the conditioned  
5739 response across trials (Gallistel et al., 2004; Pamir et al., 2014) or the time spent choosing the  
5740 rewarded stimulus. Using quantitative variables will still contain an element of arbitrariness in  
5741 the establishment of thresholds but it will give us more information about each individual and  
5742 get us closer to know which one actually learned something.

#### 5743 [Bumblebees suitability for VR experiments](#)

5744 Finally, in the last part of this manuscript we explored the possibility of using bumblebees  
5745 *Bombus terrestris* as a model in VR by measuring their performances in a color discrimination  
5746 task under VR condition and compared with honeybees. The idea for this experiment came after  
5747 we observed that honeybees that were injected with PBS solution in the central complex, the  
5748 calyces of the mushroom bodies or the antennal lobes were not able to solve the discrimination  
5749 task in VR anymore (data not shown), we thus decided to test a more robust species that could  
5750 potentially make this kind of experiment more likely to succeed.

5751 First we measured the size and weight of every individual to control for a potential effect of  
5752 weight on the ability to navigate the VR, since bigger animals should have an easier time in  
5753 moving the ball (Dahmen et al., 2017).

5754 While weight had no effect on distance or speed we found that larger bumblebees walked more  
5755 than smaller ones. This is likely due a difference in the length of each step as larger bumblebees  
5756 were also walking faster.

5757 Size and weight did not seem to affect bumblebees' learning performance in our VR  
5758 experiment. Several studies have shown that bigger bumblebees have a better visual acuity due  
5759 to having bigger eyes (Macuda et al., 2001; Spaethe and Chittka, 2003; Taylor et al., 2019;  
5760 Wertlen et al., 2008) and have better foraging success (Spaethe and Weidenmüller, 2002; Ings  
5761 et al., 2005; Klein et al., 2017). But their increased foraging success can be explained by the  
5762 fact that larger bees are able to forage in cooler conditions (Heinrich and Heinrich, 1983), may  
5763 be able to forage over larger distances, and are perhaps also less vulnerable to predation  
5764 (Goulson et al., 2002). Coherent with these observations, larger bumblebee often assume the  
5765 role of forager for the colony (Goulson, 2003), it is thus possible that their increased learning  
5766 performances observed in previous study (Worden et al., 2005) are actually a consequence of  
5767 their life experience as foragers (Giurfa et al., 2003; Cabirol et al., 2017). While bumblebees  
5768 used in Worden et al. study were allowed to forage freely at a feeder station, in our study we  
5769 used commercially reared bumblebees that were completely naive and had no foraging  
5770 experience prior to our experiment, which would then explain why the larger bumblebees did  
5771 not perform better. When investigating correlations between learning speed and foraging  
5772 success across colonies, Raine and Chittka did not evidence any link between individual forager  
5773 size and learning speed when conditioning bumblebees to collect a sucrose reward from colored  
5774 feeders in free flying conditions (Raine and Chittka, 2008). The bumblebees used in that study  
5775 were also taken from commercial colonies and had no prior exposure to colored stimuli  
5776 associated with food, this is coherent with our hypothesis that body size only affects learning  
5777 speed indirectly through foraging experience.

5778 Bumblebees were able to learn to discriminate cylinders differing in color and reinforcing  
5779 outcome in a VR context. After 6 trials, about 60% of bumblebees chose the rewarded stimulus  
5780 over the punished one. Those results are comparable with honeybees performances both in this  
5781 experiments and in previous studies (Buatois et al., 2017; Lafon et al., 2021). We also found  
5782 that using quinine solution as negative reinforcement gave better results as bumblebee  
5783 conditioned with NaCl were only able to solve the discrimination when the rewarded cylinder  
5784 was blue, a color they tend to learn faster (Gumbert, 2000). The weaker effect of salt observed  
5785 here with bumblebees is coherent with previous results found in honeybees where bees were  
5786 not able to solve the discrimination when the CS- was paired with NaCl solution (Buatois et al.,  
5787 2017).

5788 Throughout our work we have applied one consistent criterion to include or not insects in the  
5789 study: if a bee doesn't make a choice for at least half the conditioning trials it is discarded. In  
5790 this experiment this lead us to discard about 60% of honeybees. While for bumblebees, we only  
5791 discarded 11% of individuals. The higher motivation of bumblebees could be explained by their  
5792 ecology, since they tend to nest underground they might have less problem walking in the dark  
5793 for prolonged amount of time compared to honeybees, it could also be explained by a size  
5794 difference as larger bumblebees were making longer strides and thus had an easier time moving  
5795 in the VR. In any case, this makes conditioning a large number of insects easier in bumblebees  
5796 as the ratio of useable data over conditioned bees is much higher.

5797 In the past decades bumblebees have proved to be a good model to complement honeybee  
5798 research (Riveros and Gronenberg, 2009) thanks to their good cognitive abilities (Lavery,  
5799 1994; Laloi et al., 1999; Leadbeater and Chittka, 2005; Worden et al., 2005; Raine and Chittka,  
5800 2007; Leadbeater and Chittka, 2007) coupled with their robustness under restrained conditions  
5801 and during electrophysiology recordings (Paulk et al., 2008, 2009; Skorupski and Chittka, 2010;  
5802 Vähäkainu et al., 2013; Rusanen et al., 2017). In this context our results strongly suggest that

5803 the bumblebee would be an excellent model for investigating further the neural correlate of  
5804 visual learning in VR using invasive techniques, as they possess the ability to learn successfully  
5805 in VR and the robustness to endure the required surgeries.

## 5806 Conclusion

5807 So, is VR the new revolution for the study of bee behavior?

5808 Not quite. While it does allow to study visual learning in tethered animals, the throughput of  
5809 tested animals is still lower than with olfactory PER conditioning and the technical entry cost  
5810 is much higher. However, VR offers way more possibilities than PER as the animals are actually  
5811 moving and thus are more prone to exhibit a richer behavior. VR is a versatile tool, which  
5812 allows for manipulation of multiple variables and for sophisticated analyses of behavior.

5813 Overall our work improved the field of visual learning by producing a robust 3D VR system  
5814 that is inexpensive, open source and supports experiments on both bumblebees and honeybees.  
5815 We proved that it can reliably be used to condition bees in color discrimination through several  
5816 different studies, that also allowed us to refine conditioning protocols in VR. We were able to  
5817 use our setup to push our understanding of the neural mechanism of visual learning a little  
5818 further by performing the first quantification of IEGs variations in a controlled visual learning  
5819 experiment. In order to fully exploit the possibilities that this setup opens we now need to  
5820 develop a way to couple it with live recording through either calcium imaging or  
5821 electrophysiology. As a first step in that direction we also showed that bumblebees, known for  
5822 their resilience, are also a good model for the study of visual learning in VR. Taken together  
5823 our results open the way for a deeper exploration of visual learning through VR  
5824 experimentation.

5825

## 5826 References

- 5827 Bahrami, S., Drabløs, F., 2016. Gene regulation in the immediate-early response process. *Advances in*  
5828 *Biological Regulation* 62, 37–49. <https://doi.org/10.1016/j.jbior.2016.05.001>
- 5829 Baird, E., Boeddeker, N., Srinivasan, M.V., 2021. The effect of optic flow cues on honeybee flight  
5830 control in wind. *Proc. R. Soc. B.* 288, 20203051. <https://doi.org/10.1098/rspb.2020.3051>
- 5831 Baird, E., Srinivasan, M.V., Zhang, S., Lamont, R., Cowling, A., 2006. Visual Control of Flight Speed and  
5832 Height in the Honeybee, in: Nolfi, S., Baldassarre, G., Calabretta, R., Hallam, J.C.T., Marocco,  
5833 D., Meyer, J.-A., Miglino, O., Parisi, D. (Eds.), *From Animals to Animats 9*, Lecture Notes in  
5834 Computer Science. Springer, Berlin, Heidelberg, pp. 40–51.  
5835 [https://doi.org/10.1007/11840541\\_4](https://doi.org/10.1007/11840541_4)
- 5836 Balamurali, G.S., Somanathan, H., Hempel de Ibarra, N., 2015. Motion cues improve the performance  
5837 of harnessed bees in a colour learning task. *J Comp Physiol A* 201, 505–511.  
5838 <https://doi.org/10.1007/s00359-015-0994-7>
- 5839 Buatois, A., Flumian, C., Schultheiss, P., Avarguès-Weber, A., Giurfa, M., 2018. Transfer of Visual  
5840 Learning Between a Virtual and a Real Environment in Honey Bees: The Role of Active Vision.  
5841 *Front Behav Neurosci* 12, 139. <https://doi.org/10.3389/fnbeh.2018.00139>
- 5842 Buatois, A., Laroche, L., Lafon, G., Avarguès-Weber, A., Giurfa, M., 2020. Higher-order discrimination  
5843 learning by honeybees in a virtual environment. *European Journal of Neuroscience* 51, 681–  
5844 694. <https://doi.org/10.1111/ejn.14633>
- 5845 Buatois, A., Pichot, C., Schultheiss, P., Sandoz, J.-C., Lazzari, C.R., Chittka, L., Avarguès-Weber, A.,  
5846 Giurfa, M., 2017. Associative visual learning by tethered bees in a controlled visual  
5847 environment. *Sci Rep* 7. <https://doi.org/10.1038/s41598-017-12631-w>
- 5848 Cabirol, A., Brooks, R., Groh, C., Barron, A.B., Devaud, J.-M., 2017. Experience during early adulthood  
5849 shapes the learning capacities and the number of synaptic boutons in the mushroom bodies  
5850 of honey bees (*Apis mellifera*). *Learn Mem* 24, 557–562.  
5851 <https://doi.org/10.1101/lm.045492.117>
- 5852 Dahmen, H., Wahl, V.L., Pfeffer, S.E., Mallot, H.A., Wittlinger, M., 2017. Naturalistic path integration  
5853 of *Cataglyphis* desert ants on an air-cushioned lightweight spherical treadmill. *Journal of*  
5854 *Experimental Biology* 220, 634–644. <https://doi.org/10.1242/jeb.148213>
- 5855 Devaud, J.-M., Papouin, T., Carcaud, J., Sandoz, J.-C., Grünewald, B., Giurfa, M., 2015. Neural  
5856 substrate for higher-order learning in an insect: Mushroom bodies are necessary for  
5857 configural discriminations. *Proc Natl Acad Sci U S A* 112, E5854–E5862.  
5858 <https://doi.org/10.1073/pnas.1508422112>
- 5859 Frasnelli, E., Hempel de Ibarra, N., Stewart, F.J., 2018. The Dominant Role of Visual Motion Cues in  
5860 Bumblebee Flight Control Revealed Through Virtual Reality. *Front Physiol* 9.  
5861 <https://doi.org/10.3389/fphys.2018.01038>
- 5862 Fujita, N., Nagata, Y., Nishiuchi, T., Sato, M., Iwami, M., Kiya, T., 2013. Visualization of Neural Activity  
5863 in Insect Brains Using a Conserved Immediate Early Gene, *Hr38*. *Current Biology* 23, 2063–  
5864 2070. <https://doi.org/10.1016/j.cub.2013.08.051>
- 5865 Gallistel, C.R., Fairhurst, S., Balsam, P., 2004. The learning curve: implications of a quantitative  
5866 analysis. *Proc Natl Acad Sci U S A* 101, 13124–13131.  
5867 <https://doi.org/10.1073/pnas.0404965101>
- 5868 Giurfa, M., Schubert, M., Reisenman, C., Gerber, B., Lachnit, H., 2003. The effect of cumulative  
5869 experience on the use of elemental and configural visual discrimination strategies in  
5870 honeybees. *Behavioural Brain Research* 145, 161–169. [https://doi.org/10.1016/S0166-4328\(03\)00104-9](https://doi.org/10.1016/S0166-4328(03)00104-9)
- 5871 Goulson, D., 2003. *Bumblebees: Their Behaviour and Ecology*. Oxford University Press.
- 5873 Goulson, D., Peat, J., Stout, J.C., Tucker, J., Darvill, B., Derwent, L.C., Hughes, W.O.H., 2002. Can  
5874 alloethism in workers of the bumblebee, *Bombus terrestris*, be explained in terms of foraging  
5875 efficiency? *Animal Behaviour* 64, 123–130. <https://doi.org/10.1006/anbe.2002.3041>

- 5876 Gumbert, A., 2000. Color choices by bumble bees (*Bombus terrestris*): innate preferences and  
 5877 generalization after learning. *Behav Ecol Sociobiol* 48, 36–43.  
 5878 <https://doi.org/10.1007/s002650000213>
- 5879 Heinrich, B., Heinrich, M.J.E., 1983. Heterothermia in Foraging Workers and Drones of the  
 5880 Bumblebee *Bombus terrestris*. *Physiological Zoology* 56, 563–567.  
 5881 <https://doi.org/10.1086/physzool.56.4.30155879>
- 5882 Iino, S., Shiota, Y., Nishimura, M., Asada, S., Ono, M., Kubo, T., 2020. Neural activity mapping of  
 5883 bumble bee (*Bombus ignitus*) brains during foraging flight using immediate early genes. *Sci*  
 5884 *Rep* 10, 7887. <https://doi.org/10.1038/s41598-020-64701-1>
- 5885 Ings, T.C., Schikora, J., Chittka, L., 2005. Bumblebees, humble pollinators or assiduous invaders? A  
 5886 population comparison of foraging performance in *Bombus terrestris*. *Oecologia* 144, 508–  
 5887 516. <https://doi.org/10.1007/s00442-005-0081-9>
- 5888 Kiya, T., Kubo, T., 2010. Analysis of GABAergic and Non-GABAergic Neuron Activity in the Optic Lobes  
 5889 of the Forager and Re-Orienting Worker Honeybee (*Apis mellifera* L.). *PLOS ONE* 5, e8833.  
 5890 <https://doi.org/10.1371/journal.pone.0008833>
- 5891 Kiya, T., Kunieda, T., Kubo, T., 2007. Increased Neural Activity of a Mushroom Body Neuron Subtype  
 5892 in the Brains of Forager Honeybees. *PLOS ONE* 2, e371.  
 5893 <https://doi.org/10.1371/journal.pone.0000371>
- 5894 Klein, S., Pasquaretta, C., Barron, A.B., Devaud, J.-M., Lihoreau, M., 2017. Inter-individual variability in  
 5895 the foraging behaviour of traplining bumblebees. *Sci Rep* 7, 4561.  
 5896 <https://doi.org/10.1038/s41598-017-04919-8>
- 5897 Lafon, G., Howard, S.R., Paffhausen, B.H., Avarguès-Weber, A., Giurfa, M., 2021. Motion cues from  
 5898 the background influence associative color learning of honey bees in a virtual-reality  
 5899 scenario. *Sci Rep* 11, 21127. <https://doi.org/10.1038/s41598-021-00630-x>
- 5900 Laloi, D., Sandoz, J. c., Picard-Nizou, A. I., Marchesi, A., Pouvreau, A., Taséi, J. n., Poppy, G., Pham-  
 5901 delègue, M. h., 1999. Olfactory conditioning of the proboscis extension in bumble bees.  
 5902 *Entomologia Experimentalis et Applicata* 90, 123–129. <https://doi.org/10.1046/j.1570-7458.1999.00430.x>
- 5903 Laverty, T.M., 1994. Bumble bee learning and flower morphology. *Animal Behaviour* 47, 531–545.  
 5904 <https://doi.org/10.1006/anbe.1994.1077>
- 5905 Leadbeater, E., Chittka, L., 2007. The dynamics of social learning in an insect model, the bumblebee  
 5906 (*Bombus terrestris*). *Behav Ecol Sociobiol* 61, 1789–1796. <https://doi.org/10.1007/s00265-007-0412-4>
- 5907 Leadbeater, E., Chittka, L., 2005. A new mode of information transfer in foraging bumblebees? *Curr*  
 5908 *Biol* 15, R447–448. <https://doi.org/10.1016/j.cub.2005.06.011>
- 5909 Lin, A.C., Bygrave, A.M., de Calignon, A., Lee, T., Miesenböck, G., 2014. Sparse, decorrelated odor  
 5910 coding in the mushroom body enhances learned odor discrimination. *Nat Neurosci* 17, 559–  
 5911 568. <https://doi.org/10.1038/nn.3660>
- 5912 Lutz, C.C., Robinson, G.E., 2013. Activity-dependent gene expression in honey bee mushroom bodies  
 5913 in response to orientation flight. *J Exp Biol* 216, 2031–2038.  
 5914 <https://doi.org/10.1242/jeb.084905>
- 5915 Macuda, T., Gegear, R., Laverty, T., Timney, B., 2001. Behavioural assessment of visual acuity in  
 5916 bumblebees (*Bombus impatiens*). *Journal of Experimental Biology* 204, 559–564.  
 5917 <https://doi.org/10.1242/jeb.204.3.559>
- 5918 Marchal, P., Villar, M.E., Geng, H., Arrufat, P., Combe, M., Viola, H., Massou, I., Giurfa, M., 2019.  
 5919 Inhibitory learning of phototaxis by honeybees in a passive-avoidance task. *Learning and*  
 5920 *Memory* 26, 412–423. <https://doi.org/10.1101/lm.050120.119>
- 5921 Menzel, R., 2014. The insect mushroom body, an experience-dependent recoding device. *Journal of*  
 5922 *Physiology-Paris, Neuroethology: A Tribute to Hector Maldonado* 108, 84–95.  
 5923 <https://doi.org/10.1016/j.jphysparis.2014.07.004>
- 5924 Menzel, R., 1999. Memory dynamics in the honeybee. *J Comp Physiol A* 185, 323–340.  
 5925 <https://doi.org/10.1007/s003590050392>

- 5928 Pamir, E., Chakroborty, N.K., Stollhoff, N., Gehring, K.B., Antemann, V., Morgenstern, L., Felsenberg,  
5929 J., Eisenhardt, D., Menzel, R., Nawrot, M.P., 2011. Average group behavior does not  
5930 represent individual behavior in classical conditioning of the honeybee. *Learn. Mem.* 18,  
5931 733–741. <https://doi.org/10.1101/lm.2232711>
- 5932 Pamir, E., Szyszka, P., Scheiner, R., Nawrot, M.P., 2014. Rapid learning dynamics in individual  
5933 honeybees during classical conditioning. *Frontiers in Behavioral Neuroscience* 8.
- 5934 Paulk, A.C., Dacks, A.M., Gronenberg, W., 2009. Color processing in the medulla of the bumblebee  
5935 (*Apidae: Bombus impatiens*). *Journal of Comparative Neurology* 513, 441–456.  
5936 <https://doi.org/10.1002/cne.21993>
- 5937 Paulk, A.C., Phillips-Portillo, J., Dacks, A.M., Fellous, J.-M., Gronenberg, W., 2008. The Processing of  
5938 Color, Motion, and Stimulus Timing Are Anatomically Segregated in the Bumblebee Brain. *J*  
5939 *Neurosci* 28, 6319–6332. <https://doi.org/10.1523/JNEUROSCI.1196-08.2008>
- 5940 Paulk, A.C., Stacey, J.A., Pearson, T.W.J., Taylor, G.J., Moore, R.J.D., Srinivasan, M.V., Swinderen, B.  
5941 van, 2014. Selective attention in the honeybee optic lobes precedes behavioral choices. *PNAS*  
5942 111, 5006–5011. <https://doi.org/10.1073/pnas.1323297111>
- 5943 Plath, J.A., Entler, B.V., Kirkerud, N.H., Schlegel, U., Galizia, C.G., Barron, A.B., 2017. Different Roles  
5944 for Honey Bee Mushroom Bodies and Central Complex in Visual Learning of Colored Lights in  
5945 an Aversive Conditioning Assay. *Front. Behav. Neurosci.* 11.  
5946 <https://doi.org/10.3389/fnbeh.2017.00098>
- 5947 Raine, N.E., Chittka, L., 2008. The correlation of learning speed and natural foraging success in  
5948 bumble-bees. *Proc Biol Sci* 275, 803–808. <https://doi.org/10.1098/rspb.2007.1652>
- 5949 Raine, N.E., Chittka, L., 2007. Pollen foraging: learning a complex motor skill by bumblebees (*Bombus*  
5950 *terrestris*). *Naturwissenschaften* 94, 459–464. <https://doi.org/10.1007/s00114-006-0184-0>
- 5951 Riveros, A.J., Gronenberg, W., 2009. Learning from learning and memory in bumblebees. *Commun*  
5952 *Integr Biol* 2, 437–440.
- 5953 Rose, D., Blakemore, C., 1974. Effects of bicuculline on functions of inhibition in visual cortex. *Nature*  
5954 249, 375–377. <https://doi.org/10.1038/249375a0>
- 5955 Rusanen, J., Vähäkainu, A., Weckström, M., Arikawa, K., 2017. Characterization of the first-order  
5956 visual interneurons in the visual system of the bumblebee (*Bombus terrestris*). *J Comp*  
5957 *Physiol A* 203, 903–913. <https://doi.org/10.1007/s00359-017-1201-9>
- 5958 Rusch, C., Alonso San Alberto, D., Riffell, J.A., 2021. Visuo-motor feedback modulates neural activities  
5959 in the medulla of the honeybee, *Apis mellifera*. *J Neurosci.*  
5960 <https://doi.org/10.1523/JNEUROSCI.1824-20.2021>
- 5961 Rybak, J., Menzel, R., 1993. Anatomy of the mushroom bodies in the honey bee brain: the neuronal  
5962 connections of the alpha-lobe. *J Comp Neurol* 334, 444–465.  
5963 <https://doi.org/10.1002/cne.903340309>
- 5964 Schäfer, S., Bicker, G., 1986. Distribution of GABA-like immunoreactivity in the brain of the honeybee.  
5965 *J Comp Neurol* 246, 287–300. <https://doi.org/10.1002/cne.902460302>
- 5966 Sillito, A.M., 1979. Inhibitory mechanisms influencing complex cell orientation selectivity and their  
5967 modification at high resting discharge levels. *J Physiol* 289, 33–53.  
5968 <https://doi.org/10.1113/jphysiol.1979.sp012723>
- 5969 Singh, A.S., Shah, A., Brockmann, A., 2018. Honey bee foraging induces upregulation of early growth  
5970 response protein 1, hormone receptor 38 and candidate downstream genes of the  
5971 ecdysteroid signalling pathway. *Insect Molecular Biology* 27, 90–98.  
5972 <https://doi.org/10.1111/imb.12350>
- 5973 Skorupski, P., Chittka, L., 2010. Photoreceptor Spectral Sensitivity in the Bumblebee, *Bombus*  
5974 *impatiens* (Hymenoptera: Apidae). *PLOS ONE* 5, e12049.  
5975 <https://doi.org/10.1371/journal.pone.0012049>
- 5976 Spaethe, J., Chittka, L., 2003. Interindividual variation of eye optics and single object resolution in  
5977 bumblebees. *Journal of Experimental Biology* 206, 3447–3453.  
5978 <https://doi.org/10.1242/jeb.00570>

- 5979 Spaethe, J., Weidenmüller, A., 2002. Size variation and foraging rate in bumblebees (*Bombus*  
5980 *terrestris*). *Insectes soc.* 49, 142–146. <https://doi.org/10.1007/s00040-002-8293-z>
- 5981 Taylor, G.J., Tichit, P., Schmidt, M.D., Bodey, A.J., Rau, C., Baird, E., 2019. Bumblebee visual allometry  
5982 results in locally improved resolution and globally improved sensitivity. *eLife* 8, e40613.  
5983 <https://doi.org/10.7554/eLife.40613>
- 5984 Tsumoto, T., Eckart, W., Creutzfeldt, O.D., 1979. Modification of orientation sensitivity of cat visual  
5985 cortex neurons by removal of GABA-mediated inhibition. *Exp Brain Res* 34, 351–363.  
5986 <https://doi.org/10.1007/BF00235678>
- 5987 Ugajin, A., Uchiyama, H., Miyata, T., Sasaki, T., Yajima, S., Ono, M., 2018. Identification and initial  
5988 characterization of novel neural immediate early genes possibly differentially contributing to  
5989 foraging-related learning and memory processes in the honeybee. *Insect Molecular Biology*  
5990 27, 154–165. <https://doi.org/10.1111/imb.12355>
- 5991 Vähäkainu, A., Vähäsöyrinki, M., Weckström, M., 2013. Membrane filtering properties of the  
5992 bumblebee (*Bombus terrestris*) photoreceptors across three spectral classes. *J Comp Physiol*  
5993 A 199, 629–639. <https://doi.org/10.1007/s00359-013-0814-x>
- 5994 Wertlen, A.M., Niggebrügge, C., Vorobyev, M., Hempel de Ibarra, N., 2008. Detection of patches of  
5995 coloured discs by bees. *Journal of Experimental Biology* 211, 2101–2104.  
5996 <https://doi.org/10.1242/jeb.014571>
- 5997 Worden, B.D., Skemp, A.K., Papaj, D.R., 2005. Learning in two contexts: the effects of interference  
5998 and body size in bumblebees. *Journal of Experimental Biology* 208, 2045–2053.  
5999 <https://doi.org/10.1242/jeb.01582>
- 6000 Zwaka, H., Bartels, R., Lehfeldt, S., Jusyte, M., Hantke, S., Menzel, S., Gora, J., Alberdi, R., Menzel, R.,  
6001 2019. Learning and Its Neural Correlates in a Virtual Environment for Honeybees. *Front*  
6002 *Behav Neurosci* 12, 279. <https://doi.org/10.3389/fnbeh.2018.00279>
- 6003

# Curriculum Vitae

# Lafon Grégory

PHD · NEUROETHOLOGY

4 Avenue des Croisés, 31520, Ramonville Saint-Agne

✉ gregory.lafon@univ-tlse3.fr | 🌐 <https://github.com/G-Lafon>

## Education

---

### Université Toulouse III - Paul Sabatier

PHD NEUROETHOLOGY: "VISUAL LEARNING IN BEES UNDER VIRTUAL REALITY CONDITIONS"

- Co-Supervisors: Pr. Martin Giurfa, Dr. Aurore Avarguès-Weber

*Toulouse, France*

*2018 - 2022*

### ENS Cachan

ENS CACHAN DIPLOMA

- Successfully completed the 4 year program of the ENS Cachan

*Paris, France*

*2013 - 2017*

### Université Toulouse III - Paul Sabatier

MASTER NEUROSCIENCE, BEHAVIOUR, COGNITION

*Toulouse, France*

*2017 - 2018*

### ENS Lyon

MASTER EARTH AND LIFE SCIENCES

*Lyon, France*

*2015 - 2016*

### ENS Cachan

LICENCE BIOLOGY

*Paris, France*

*2013 - 2014*

### Lycée Henri IV

CPGE BCPST

- Admission at the ENS Cachan, 32th out of 800

*Paris, France*

*2010 - 2013*

## Research Experience

---

### Université Toulouse III - CRCA-CBI

CO-SUPERVISORS: PR. MARTIN GIURFA, DR. AURORE AVARGUÈS-WEBER

- PhD: Visual learning in Honey bees under virtual reality conditions

*Toulouse, France*

*2018 - 2022*

### McGill University - Dept of Biology

SUPERVISOR: DR. JON SAKATA

- Internship: Role of dopamine within HVC in social context related song modifications

*Montreal, Canada*

*Nov.2016 - Aug.2017*

### Université Pierre et Marie Curie - Dept of Neuroscience

SUPERVISOR: DR. CHRISTELLE ROCHEFORT

- Internship: Influence of LTP in synapses between parallel fibers and Purkinje cells on place cells

*Paris, France*

*Jun - July 2015*

### University Paris-Saclay, CNRS

SUPERVISOR: DR. JEAN-CHRISTOPHE SANDOZ

- Internship: Influence of maturity on olfactory attraction between western honey bee drones

*Gif-Sur-Yvette, France*

*Jun - July 2014*

## Teaching Experience

---

2018 - 2021	<b>Ethology</b> , Practical Course, Teaching Assistant	Université Toulouse III
2018 - 2021	<b>Behavioural Ecology</b> , Practical Course, Teaching Assistant	Université Toulouse III
2019 - 2020	<b>Biology of Behaviour</b> , Practical Course, Teaching Assistant	Université Toulouse III
2020	<b>Introduction to the Scientific Method</b> , Practical Course, Teaching Assistant	Université Toulouse III
2018	<b>Behavioural Neuroscience</b> , Practical Course, Teaching Assistant	Université Toulouse III

## Mentoring

---

2021	<b>Naïs Judan (BS), Eva Blot (BS), and Karolina Pecharova (MS)</b> , Visual learning in bumble bees under virtual reality conditions	Université Toulouse III
2021	<b>Catherine Macri (MS), Marin Nicola (MS)</b> , Evaluation of cerebral nanoinjection's effects on visual learning performances under virtual reality conditions in <i>Apis mellifera</i>	Université Toulouse III
2021	<b>Clemence Guinnement (MS)</b> , Redaction of a review on the neurobiological mechanism of visual learning in the honey bee	Université Toulouse III
2019	<b>Rodrigue Fouillet (MS), Juliette Montet (MS), Diane Sam Mine (BS), Emma Giordanengo (BS)</b> , Influence of Background motion cues in VR on color discrimination in the honey bee	Université Toulouse III

## Skills

---

Animal handling	<b>Beekeeping, Insect conditioning, Basic dissections</b>
Technical Skills	<b>3D printing, Arduino, Soldering</b>
Languages	<b>French, English</b>
Programming	<b>C++, C#, R, Gdscript</b>
Dev tools	<b>Github, Unity, Visual Studio</b>
Graphic tools	<b>Gimp, Aseprite</b>

## Publications

---

### PUBLISHED

- Gregory Lafon\***, Haiyang Geng\*, Aurore Avarguès-Weber, Alexis Buatois, Isabelle Massou, Martin Giurfa. 2022. The Neural signature of visual learning under restrictive virtual-reality conditions. *Frontiers in Behavioral Neuroscience*, 16:846076. doi: 10.3389/fnbeh.2022.846076
- Haiyang Geng\*, **Gregory Lafon\***, Aurore Avarguès-Weber, Alexis Buatois, Isabelle Massou, Martin Giurfa . 2022. Visual learning in a virtual reality environment upregulates immediate early gene expression in the mushroom bodies of honey bees. *Communications Biology*, 14;5(1):130. doi: 10.1038/s42003-022-03075-8
- Gregory Lafon**, Scarlett R. Howard, Benjamin H. Paffhausen, Aurore Avarguès-Weber, Martin Giurfa . 2021. Motion cues from the background influence associative color learning of honey bees in a virtual-reality scenario. *Scientific Reports*, 11(1):21127, doi: 10.1038/s41598-021-00630-x
- Alexis Buatois, Lou Laroche, **Gregory Lafon**, Aurore Avarguès-Weber, Martin Giurfa . 2020. Higher order discrimination learning by honey bees in a virtual environment. *European Journal of Neuroscience*, 51(2):681-694, doi: 10.1111/ejn.14633
- Florian Bastin, Hanna Cholé, **Grégory Lafon**, Jean-Christophe Sandoz . 2017. Virgin queen attraction toward males in honey bees. *Scientific Reports*, 7(1):6293. doi: 10.1038/s41598-017-06241-9

Florian Bastin, Fabrice Savarit, **Grégory Lafon**, Jean-Christophe Sandoz . 2017. Age-specific olfactory attraction between Western honey bee drones (*Apis mellifera*) and its chemical basis. PLoS One, 12(10):e0185949. doi: 10.1371/journal.pone.0185949

\* first authorship shared

## IN PREP

**Gregory Lafon**, Aurore Avarguès-Weber, Martin Giurfa . Comparison of associative visual learning in a 3D virtual reality between bumble bees and honey bees.

## Other Projects

---

### OPEN SOURCE DEVELOPMENT

2019-.. **Cataclysm: Dark Days Ahead**, Core dev team member [cataclysmdda.org](http://cataclysmdda.org)