



PETROVIETNAM EXPLORATION PRODUCTION CORPORATION LTD  
DOMESTIC PETROLEUM OPERATING BRANCH - PETROVIETNAM  
EXPLORATION PRODUCTION CORPORATION LIMITED

15<sup>th</sup> Floor, Victory Tower  
No. 12 Tan Trao Street, Tan My Ward,  
Ho Chi Minh City, SR. Vietnam

Tel: (84-28) 37762222  
Fax: (84-28) 38721079  
Email: [pvep.poc@pvep.com.vn](mailto:pvep.poc@pvep.com.vn)

**FACSIMILE TRANSMISSION**

To: **Bidders**  
Attn.: **Directors**

Fax No.: N/A

Ref.: 27 /PVEPPOC-PPM

Date: 7<sup>th</sup> Jan, 2026

No. of page(s) (including this cover sheet): 01

**INVITATION TO BID**

**TENDER TITLE: MOORING HAWSERS AND ACCESSORIES 2026**  
**Tender No. : PVEPPOC-25-10391**

*If you have not received the full text of this letter, please call (84-28) 37762222*

Dear Sir,

DOMESTIC PETROLEUM OPERATING BRANCH - PETROVIETNAM EXPLORATION PRODUCTION CORPORATION LIMITED (hereinafter referred to as "CLIENT") hereby solicits a competitive proposal for the MOORING HAWSERS AND ACCESSORIES 2026 (hereinafter referred to as "GOODS"). CLIENT hereby invites BIDDER to submit its Bid Proposal for the GOODS in accordance with this Invitation to Bid and the Instructions To Bid (hereinafter referred to as "DOCUMENT"). BIDDER shall be binding to enter into a Contract agreement with CLIENT if the Contract is awarded to BIDDER in accordance with the Terms & Conditions shall be mutually agreed during bidding process.

BIDDER's Bid Proposal must be received by CLIENT not later than **10:00 HOURS, 23<sup>rd</sup> Jan 2025 (Vietnam Time, GMT+7)** ("Bid Closing Date") at the CLIENT's address.

BIDDER's Bid Proposal shall be binding for a period of one hundred and twenty (120) calendar days from Bid Closing Date. Any changes associated with BIDDER's Bid Proposal after Bid Closing Date shall not be allowed and may result in BIDDER's Proposal being disqualified. Any Tender clarification(s) must be made in writing to the undersigned. Unofficial visits and or discussions with CLIENT shall not be allowed throughout the bidding progress.

Please download soft DOCUMENT on <https://muasamcong.mpi.gov.vn/>.

Yours faithfully,  
*For and On Behalf of CLIENT*

**NGUYEN XUAN NINH**  
Director



## **TENDER PACKAGE**

Tender No.: PVEPPOC-25-10391

**MOORING HAWSERS AND ACCESSORIES 2026**

-----  
CLOSING TIME & DATE

10:00am, ...*23<sup>rd</sup> January*..., 2025 (Vietnam Time)

**GENERAL TABLE OF CONTENTS**  
**INVITATION TO BID (ITB)**

**PART I - ITB INSTRUCTIONS**

1. INSTRUCTIONS AND INFORMATION TO BIDDER
2. BIDDER'S QUESTIONNAIRE
3. BIDDING FORMS
4. PRELIMINARY AND TECHNICAL EVALUATION CRITERIA

**PART II – CONTRACT DOCUMENT**

1. CONTRACT FORM
2. EXHIBITS
  - EXHIBIT I SCOPE OF SUPPLY AND TECHNICAL REQUIREMENTS
  - EXHIBIT II CONTRACT PRICE
  - EXHIBIT III SHIPPING DOCUMENT, PACKING AND MARKING REQUIREMENTS
  - EXHIBIT IV FORM OF BANK GUARANTEE
  - EXHIBIT V FORM OF ACCEPTANCE PROTOCOL
  - EXHIBIT VI FORM OF CONTRACT CLOSURE CERTIFICATE

**PART I: ITB INSTRUCTIONS**

**1. INSTRUCTIONS AND INFORMATION TO BIDDER**

*[Handwritten initials]*

## INSTRUCTIONS AND INFORMATION TO BIDDER

### **1.0 GENERAL**

1.1 DOMESTIC PETROLEUM OPERATING BRANCH - PETROVIETNAM EXPLORATION PRODUCTION CORPORATION LIMITED (hereinafter referred to as "CLIENT") invites BIDDER to submit proposal for MOORING HAWSERS AND ACCESSORIES 2026 (hereinafter referred to as "GOODS") under ITB No.: PVEPPOC-25-10391.

1.2 In order for CLIENT to fully assess the relative merits of each proposal, BIDDER is requested to furnish CLIENT with all relevant and complete information as set forth in the following items of "INSTRUCTIONS AND INFORMATION TO BIDDER". BIDDER is urged to comply strictly with ITB's requirements.

#### 1.3 Eligibility of BIDDER

a. BIDDER shall be eligible required as follows:

In case of independent BIDDER:

- **Domestic BIDDER** is to provide notarized copy of eligible certificate of business registration in accordance with Vietnamese Laws;
- **Foreign BIDDER** is to provide notarized copy of eligible certificate of business registration in accordance with the law of BIDDER'S country;
- BIDDER is an independent cost accounting entity;
- There is no decision by a competent authority concluding that the BIDDER has an unhealthy financial status; BIDDER is not in bankrupt or insolvent status, and BIDDER is not in the process of dissolution.
- BIDDER participates in bid must be legally and financially independent with Investor and/or Procuring Entity. Failure to comply with such requirement may be considered as disqualified.

b. In case of Consortium:

- Each Consortium Partner is to provide the documents and to meet the requirements mentioned in paragraph 1.3.a. above.
- Written Consortium Agreement between the consortium partners specifying responsibilities (joint and several) of each Consortium Partner in implementing the Bid, rights and scope of work and respective value of each Consortium Partner, including the Leading Consortium Partner and its responsibility, place and date of signing the Consortium Agreement, signatures and seals (if any) of Consortium Partners. If the Consortium Partner is authorized as the Leading Partner to sign the Proposal Letter, this effect shall be stated in the Consortium Agreement).

c. BIDDER is to ensure the competition in bidding procedures as follows:

- BIDDER who has prepared the Technical Design, Construction Drawing Designs or Technology Design for this ITB is not allowed to participate in Bidding for Supply of GOODS under this ITB.
- BIDDER participating in this ITB must be organizationally independent of, financially independent from, and not under the control of the managing body of CLIENT in accordance with the applicable laws of Vietnam.

1.4. BIDDER must submit its proposal strictly in accordance with the terms of the ITB which consists of the following:

**PART I - ITB INSTRUCTIONS**

INSTRUCTIONS AND INFORMATION TO BIDDER

BIDDER'S QUESTIONNAIRE

BIDDING FORMS

PRELIMINARY AND TECHNICAL EVALUATION CRITERIA

**PART II – CONTRACT DOCUMENT**

CONTRACT FORM

**EXHIBITS:**

EXHIBIT I SCOPE OF SUPPLY AND TECHNICAL REQUIREMENTS

EXHIBIT II CONTRACT PRICE

EXHIBIT III SHIPPING DOCUMENT, PACKING AND MARKING REQUIREMENT

EXHIBIT IV FORM OF BANK GUARANTEE

EXHIBIT V FORM OF ACCEPTANCE PROTOCOL

EXHIBIT VI FORM OF CONTRACT CLOSURE CERTIFICATE

1.5 As a base case, **BIDDER's proposal should be in full conformity with the requirements as set out in the ITB.** Nothing shall be deemed to change or supplement this basis except revisions or addendum to the ITB issued in writing by CLIENT to BIDDER. If BIDDER wishes to present an alternative (applicable to Technical Specifications ONLY), BIDDER may do so (as an option to CLIENT) only after having duly complied with the requirements of the ITB.

1.6 Any queries concerning preparation of the proposal shall be directed in writing to the address given in item 9.3.

1.7 All Bid Proposals must be signed by an officer duly authorized by BIDDER to do so.

1.8 Any amendment appearing in the Bid Proposal must be signed or initialed by an officer duly authorized by BIDDER to do so.

1.9 BIDDER is to ensure that all prices and other details in the proposal are correct at the time of submission. CLIENT will not entertain any changes or addenda due to typing or calculation errors after the Bid Closing Date.

1.10 BIDDER is to bear responsibility for and pay all costs, expenses and other charges incurred

in preparation and delivery of the proposal to CLIENT's designated office as stated in item 9.3, irrespective of whether an order is placed or not.

- 1.11 Submission of proposal by BIDDER will constitute a firm offer by BIDDER that BIDDER is prepared to enter into Contract with CLIENT on the conditions shown in this ITB.
- 1.12 Proposal by BIDDER shall be binding for a minimum period of 120 calendar days from the Bid Closing Date. BIDDER may assume that the award for Contract will be made within 120 calendar days from the Bid Closing Date and BIDDER can assume that it has not been successful if no notification is received within the bid validity period. BIDDER shall state the precise date of validity in the proposal. CLIENT shall be entitled to request BIDDER to extend Bid Validity for maximum of 30 calendar days (if any) without any BIDDER's exception.
- 1.13 BIDDER is requested to use the term "CONTRACTOR" instead of its specific company business name in their submission of Bid Proposal except for covering letter, header and footer.
- 1.14 At any time prior to Bid Closing Date, CLIENT, for any reason, whether at its own initiative or in response to a clarification requested by BIDDER, may modify the ITB by amendment (including the extension of Bid Closing Date, if necessary) by sending the amendment of ITB in writing to all BIDDERS prior to the Bid Closing Date. These amendments shall be the part of ITB. BIDDERS shall notify to CLIENT by email or by fax to acknowledge their receipt of said amendments.
- 1.15 FAILURE TO STRICTLY COMPLY WITH THE INSTRUCTION AS SET FORTH IN THIS DOCUMENT WILL RESULT IN BIDDER'S PROPOSAL BEING DEEMED NON-RESPONSIVE IN WHICH CASE IT MAY BE DROPPED FROM FURTHER CONSIDERATION.

## **2.0 INTENTION TO BID**

- 2.1 BIDDER is advised to thoroughly check the completeness of the ITB upon receipt. BIDDER must inform CLIENT within three (3) days from the bid issue date if any of the pages are missing.
- 2.2 BIDDER is required to acknowledge receipt of the ITB in accordance with the ITB Acknowledgement Letter Form set out in BIDDING FORMS and intention to submit proposal or otherwise by fax **at least two (2) working days** from bid issuance date. BIDDER is also advised to confirm its address and name a representative to whom all communications from CLIENT shall be addressed to.
- 2.3 Should BIDDER decline to submit a proposal, BIDDER shall state in writing the reason(s) for declining and is required to promptly return the ITB to CLIENT, and in all such cases this shall be done not later than the bid closing date.
- 2.4 All ITB returned shall be forwarded to the address as given in item 9.3 herein, with the following wordings clearly marked on the cover/envelope.

- (a) "DECLINE TO BID-DOCUMENTS RETURNED"
- (b) ITB NUMBER and TITLE
- (c) BIDDER'S NAME

### **3.0 EXCLUSIVITY OF BID**

BIDDER is required to submit Bid Proposal in conjunction with the Principal and the Principal MUST be the prime vendor for the total proposal package. BIDDER is also required to submit a support letter from Principal (if any).

### **4.0 SCOPE OF SUPPLY**

BIDDER's Scope of Supply shall be in accordance with ITB which are listed in the Table of Contents.

GOODS to be supplied under this ITB shall origin from eligible source country and defined in Exhibit I – Scope of Supply and Technical Requirements of the Contract Form.

The origin of GOODS is understood as a country or territory where GOODS were mined, grown, cultivated, produced, manufactured or where GOODS and its parts are processed, assembled, further manufactured to have a merchantable product that has substantial differentiation from the components from which it is composed.

### **5.0 PRICE QUOTATION**

- 5.1 The price quotation shall be quoted in Vietnamese Dong (VND), for Domestic BIDDER or United States Dollar (USD), for Foreign BIDDER.
- 5.2 Once specified, the unit prices shall prevail throughout the life of the Contract and shall not be subject to revision by reason of cost escalation nor currency fluctuations.
- 5.3 **PRICE OF GOODS**
  - 5.3.1 BIDDER's Bid Proposal shall be in full conformity with the requirements as set out in this Bid documents.
  - 5.3.2 BIDDER should specifically note that subsequence to the Bid Closing Date, no alteration in price quotation will be permitted whatsoever.
  - 5.3.3 Prices are to be itemized according to the item numbers in the Commercial Summary Form attached hereto. Unit price and total price must be clearly stated in the quotation. All discounts, in percentage of total estimated contract value, are to be stated separately.
- 5.4 The proposed CONTRACT PRICE shall indicate whether it is inclusive of Vietnamese taxes (VAT, CIT, etc.) or not. In the event that the quoted prices do not specify this, they shall be treated as inclusive of all taxes.

### **6.0 BID EXCEPTIONS**

In the event BIDDER has any change that is considered of mutual benefit or if there is any exception to ITB document, BIDDER must state the changes or exceptions proposed by using the Exception Form as set out in BIDDING FORMS and giving specific reasons thereof.

Changes or exceptions to the ITB document expressed after the Bid Closing Date will not be entertained.

CLIENT reserves the right to accept or reject any or all of the proposed changes or exceptions. CLIENT will review each change or exception on a case-by-case basis.

## **7.0 BID BOND/ BANK GUARANTEE**

### **7.1 BID BOND**

7.1.1 When participating to the Bid, BIDDER shall, at its own expense, furnish Bid Bond using the Bid Bond Form set out in BIDDING FORMS and issued by reputable recognized bank accepted by CLIENT.

7.1.2 The amount of Bid Bond shall be 59,000,000 VND (In words: Fifty-nine million Vietnam Dong) and shall be valid for **150 days from the Bid Closing Date**. The Original Bid Bond shall be attached in the Bid Proposal (*the amount of Bid Bond as required in website "muasamcong.mpi.gov.vn"*).

7.1.3 In case of Consortium, the Bid Bond will be provided by one of the following two methods:

- a) Each Consortium Partner shall provide separately Bid Bond, provided always that the total value of Bid Bond shall not be lower than the amount required in Item 7.1.2 above; if Bid Bond of any Consortium Partner is invalid the Bid Proposal of such Consortium shall be rejected according to the prerequisite criteria.
- b) The Consortium Partners agree to appoint a Consortium Partner to provide Bid Bond for the whole Consortium. In this case, the Bid Bond may include the name of Consortium or name of the Consortium Partner providing the Bid Bond for the whole Consortium provided always that the total value of Bid Bond shall not lower than the amount required in Item 7.1.2 above.

7.1.4 Bid Bond shall be considered as not acceptable if its value is lower than the required value, is not in the required currency, with shorter validity period, not submitted to the address by the time required by the ITB, states an incorrect BIDDER'S Name, is not original or without valid signature.

7.1.5 Bid Bond will be returned to the unsuccessful BIDDER within thirty (30) days from the date of announcement of the Bid results. For the successful BIDDER, the Bid Bond will be returned when the successful BIDDER provides the Bank Guarantee.

7.1.6 Bid Bond shall be forfeited and shall be disposed if the BIDDER:

- a) withdraws its Bid Proposal during the Validity Period of the Bid or any extension of validity the BIDDER has agreed to;
- b. do not commence the contract negotiation, finalization or decline to do so within thirty (30) days after receipt of contract award notice, or have completed the contract negotiation, finalization but refuses to sign the contract without valid reasons;
- c. in case of the successful BIDDER, fails to furnish the performance bond before signing the contract or before the contract comes into force.

**7.2 BANK GUARANTEE**

BIDDER's attention is drawn to **Article headed as BANK GUARANTEE** of the CONTRACT FORM whereby the successful BIDDER is requested to provide an irrevocable first call Bank Guarantee issued by a commercial bank acceptable by CLIENT to guarantee performance of BIDDER's obligation under the CONTRACT. The format of Bank Guarantee shall be set out in the EXHIBIT IV of CONTRACT document.

**8.0 PROPOSAL FORMAT**

8.1 BIDDER is to strictly adhere to the proposal format as set out below. **BIDDER must ensure that the "TECHICAL AND UNPRICED PACKAGE (TECHNICAL)" does not contain any pricing or cost.** Failure to comply with these instructions may render BIDDER's proposal invalid.

8.2 BIDDER is to submit the proposal in two (2) separate packages, as follows:

- a) Technical and Unpriced Package (Technical)
- b) Priced Package (Commercial)

**8.3 CONTENTS OF TECHNICAL AND UNPRICED PACKAGE (TECHNICAL)**

Unpriced package shall include but not limited to the following:

SECTION	CONTENT
Section 1	<p><b>PROPOSAL LETTER</b></p> <p>The Proposal Letter shall be prepared and fully filled by BIDDER as set out in BIDDING FORMS and must be signed by the authorized representative of BIDDER (the representative at law of the BIDDER or the authorized person with legal Power of Attorney). In case of authorization, BIDDER shall enclose the following instruments and documents to prove the legitimacy of the authorized person:</p> <ul style="list-style-type: none"> <li>a. In case of independent BIDDER: <ul style="list-style-type: none"> <li>Power of Attorney signed by the Representative at law of BIDDER authorizing the authorized person to sign the Proposal Letter;</li> </ul> </li> <li>b. In case of Consortium: <ul style="list-style-type: none"> <li>Proposal Letter shall be signed by the Representative at law of each Consortium</li> </ul> </li> </ul>

	<p>Partner, unless the Consortium Agreement stated that the Consortium Partners have authorized the representative at law of Leading Partner of the Consortium to sign Proposal Letter. If each Consortium Partner has authorized such Representative, the same requirements as independent Bidder shall be applied.</p>
Section 2	<p><b>BIDDER'S ELIGIBILITY, EXPERIENCES AND CAPACITY</b></p> <p>BIDDER shall provide the following documents proving BIDDER's eligibility, experiences, and capacity:</p> <ul style="list-style-type: none"> <li>- The Documents as required in Item 1.3;</li> <li>- BIDDER is requested to submit a completed BIDDER's QUESTIONNAIRE, including but not limitation to the following documents: <ul style="list-style-type: none"> <li>(i) Past Work Experience; and</li> <li>(ii) Company Profile; and</li> <li>(iii) Last 3 Year Financial Statement.</li> </ul> </li> </ul>
Section 3	<p><b>TECHNICAL PROPOSAL</b></p> <p>BIDDER shall provide the following documents to prove the suitability (compliance) of GOODS:</p> <ul style="list-style-type: none"> <li>- Detailed List of GOODS in compliance with EXHIBIT I - Scope of Supply and Technical Requirements of CONTRACT document;</li> <li>- Supply Schedule in compliance with EXHIBIT I - Scope of Supply and Technical Requirements of CONTRACT document;</li> <li>- Technical documents such as quality standard, features, technical specification, warranty parameters of each type of GOODS (attach drawings for description, if necessary);</li> <li>- License for Sale of Manufacturer in accordance with the License for Sale of the Manufacturer Form as set out in BIDDING FORMS or Letter of Authorization of Distributor;</li> <li>- the origin of GOODS as stipulated in Item 4, code, trademark of the product, and related documents proving the eligibility of GOODS;</li> <li>- other requirements as stipulated EXHIBIT I - Scope of Supply and Technical Requirements;</li> </ul>
Section 4	<p><b>BID BOND</b></p> <p>BIDDER shall provide the Original Bid Bond as requested in Item 7.1.</p>
Section 5	<p><b>BIDDER'S EXCEPTIONS TO CONTRACT DOCUMENT</b></p> <p>BIDDER shall provide BIDDER's Exception to CONTRACT document as stated in Item 6, if any.</p>

8.4 CONTENTS OF PRICED PACKAGE (COMMERCIAL)

Every page of BIDDER's price proposal must bear BIDDER's company seal. Priced package shall include the following:

SECTION	CONTENT
Section 1	<b>PROPOSAL LETTER</b> To be attached a similar letter as in Section 1.
Section 2	BIDDER is requested to submit the following with prices & schedule attached a <b>PRICED COMMERCIAL FORM</b> as per the EXHIBIT II – CONTRACT PRICE
Section 3	<b>BIDDER's PRICED EXCEPTIONS AND ALTERNATIVES.</b> a) If BIDDER has no exception and alternative proposal, BIDDER shall have the following statements prominently displayed in capital letters under this section: "THIS PROPOSAL COMPLIES WITH ALL TERMS AND CONDITIONS OF THIS CONTRACT, EXHIBITS AND REQUIREMENTS IN THIS TENDER" or b) If BIDDER has an alternative proposal on this bid documents, BIDDER shall display the following statement in capital letters under this section: "THIS PROPOSAL INCLUDES EXCEPTIONS AND ALTERNATIVES WHICH ARE LISTED ON THE FOLLOWING PAGES."  BIDDER shall present a complete and detailed listing of non-compliance to the Tender in total indicating the delivery impact and cost impact, if any. The format of the presentation shall be as per the attached BIDDER's EXCEPTION TO TERMS AND CONDITIONS and BIDDER's EXCEPTION TO EXHIBITS as set out in BIDDING FORMS.

9.0 SUBMISSION OF PROPOSAL

9.1 Each Technical and Unpriced Package (Technical) and Priced Package (Commercial) shall consist of:

- a) **One (1) original set** of each package wrapped separately from the other copies and clearly marked with the word "**ORIGINAL UNPRICED**" or "**ORIGINAL PRICED**" on the cover of the respective wrapping.
- b) **One (1) Copy** each of the Technical and Unpriced Package (Technical) and Priced Package (Commercial). The copies shall be wrapped separately (Unpriced and Priced) and marked with the word "**COPY UNPRICED PACKAGE**" or "**COPY PRICED PACKAGE**" on the covers of the packages.

In the event of discrepancy between the original set and the copies, the original set shall prevail.

9.2 BIDDER shall ensure that all proposals or submissions to CLIENT, pertaining to the

enquiry are properly sealed and that the cover of each package is clearly marked in **bold letters** with the following wordings:

- (a) ITB number and the title.
- (b) BIDDER's name and return address.
- (c) "TECHNICAL AND UNPRICED PACKAGE" or "PRICED PACKAGE".
- (d) "PRIVATE AND CONFIDENTIAL"

9.3 **All communications and correspondence with regard to ITB and clarification shall be made to the following address:**

**DOMESTIC PETROLEUM OPERATING BRANCH - PETROVIETNAM  
EXPLORATION PRODUCTION CORPORATION LIMITED**

15th Floor, Victory Tower

12 Tan Trao Street, Tan My Ward, Ho Chi Minh City, S.R Vietnam

Tel: (84-28) 37762222

Fax: (84-28) 38721079

Attention : **Planning & Procurement Department Manager**

All communications with regard to bid clarifications shall be made in writing and must indicate the ITB number and title and send to the address given above. Such bid clarifications shall reach the address given above at least ten (10) days prior to the Bid Closing Date. CLIENT shall preserve the right not to respond to bid clarifications received later than the above mentioned time.

**Submission of Bid Proposal shall be made to the following address:**

**DOMESTIC PETROLEUM OPERATING BRANCH - PETROVIETNAM  
EXPLORATION PRODUCTION CORPORATION LIMITED**

15th Floor, Victory Tower

12 Tan Trao Street, Tan My Ward, Ho Chi Minh City, S.R Vietnam

Tel: (84-28) 37762222

Fax: (84-28) 38721079

Attention : **Planning & Procurement Department Manager**

- 9.4 BIDDER is strongly advised to deliver the proposals by hand in order to assure timely receipt by CLIENT. If BIDDER elects to mail the proposal, BIDDER is advised to use a fast and reliable delivery service e.g. courier. BIDDER should advise CLIENT by fax the date on which the proposal was mailed and details of the delivery service.
- 9.5 Responsibility for timely delivery of the proposals to the correct address rests fully with BIDDER. CLIENT does not accept late bids submission. Delivery to the wrong address shall not be an excuse for late delivery.
- 9.6 BIDDER must ensure that the proposal is delivered to the address given in Item 9.3 above no later than **the Bid Closing Date specified on the website “muasamcong.mpi.gov.vn”**

**for this ITB, LATE BIDS WILL NOT BE ENTERTAINED.**

- 9.7 BIDDER's proposal shall be submitted in a **separate sealed envelope or package** bearing the name of your company, clearly addressed and marked on the outside as follows:

**"STRICTLY CONFIDENTIAL"**

**MOORING HAWSERS AND ACCESSORIES 2026**

**ITB NO.: PVEPPOC-25-10391**

- 9.8 Bid Proposal as well as all correspondences and documents relating to the ITB exchanged by BIDDER and CLIENT shall be written in English. Supporting documents and printed literature furnished by BIDDER may be in another language provided they are accompanied by an accurate translation of the relevant passages in English, in which case, for purposes of interpretation of the Bid Proposal, the translation shall govern.

#### **10.0 ACCEPTANCE**

- 10.1 CLIENT may, at CLIENT option, reject all proposals received or may accept any proposal which, in CLIENT's sole judgment, is the most advantageous to CLIENT. CLIENT reserves the right to accept or reject all or part of the proposal at CLIENT's discretion and will be under no obligation to explain the reasons thereof.
- 10.2 Award strategy: Single Award. CLIENT reserves the right to award the CONTRACT at its own discretion.
- 10.3 CLIENT shall not be deemed to have accepted all or any part of a proposal unless and until a written acceptance is issued.
- 10.4 Any award as a result of this ITB will be through a properly executed contract issued by CLIENT. Prior to this, CLIENT may send the BIDDER a Letter of Award in order to initiate immediate placement of order. Upon receipt of the Letter of Award, BIDDER shall proceed immediately with the work mentioned in the Letter of Award.

#### **11.0 PAYMENT**

- 11.1 Payments shall be made in accordance to **Article headed as INVOICING AND PAYMENT** of Contract Form attached hereto.
- 11.2 Any proposal on progress payments shall be based on "value received" or verifiable milestones and not merely the passage of time and not for merely placing the Contract.

**END OF SECTION**

**PART I: ITB INSTRUCTIONS**

**2. BIDDER'S QUESTIONNAIRE**

**BIDDER'S QUESTIONNAIRE**

(This form **MUST** be completely filled by BIDDER. Write 'NA' or 'NOT APPLICABLE' where appropriate)

**PRIVATE & CONFIDENTIAL**

1. Full Name of BIDDER: \_\_\_\_\_  
 Registered Address: \_\_\_\_\_  
 Business Address: \_\_\_\_\_  
 Correspondence Address: \_\_\_\_\_  
 Telephone: \_\_\_\_\_  
 Fax: \_\_\_\_\_

2. BIDDER's Organization:  
 BIDDER is requested to provide a brief description of the background and organization of BIDDER.

3. List of similar Projects and Contract performed in the last three years:

Name of Project: .....	Approx. Value of Contract (in current US\$/VND): .....
Country: .....	Duration of Project (months): .....
Location within country: .....	
Name of Client: .....	Total N <sup>o</sup> of staff-months provided to the Project: .....
Address: .....	Start Date (month/year): .....
	Completion Date (month/year): .....
Narrative description of Project: .....	Description of actual services provided by BIDDER's staff within Project: .....
Name of senior professional staff of BIDDER involved and functions performed (indicate most significant profiles such as Project Director/Coordinator, Team Leader): .....	

Note: BIDDER shall attach a copy of documents, materials related to above contracts (certified by the Project Owner for the contract being implemented according to the related information in above table).

4. Summary of Financial Data for the fiscal years

Unit: \_\_\_\_\_ (VND/ USD)

No.	Descriptions	2022	2023	2024
1	Total assets			
2	Total liabilities			
3	Current assets			
4	Current liabilities			
5	Turnover			
6	Profit Before Tax			
7	Profit after Tax			
8	Other items (if required)			

For the purpose of verification of the data declared, BIDDER is required to submit the notarized/certified true copy of the following documents:

1. Audited Financial Statements or Financial Statements certified by competent authorities as required by the law for the Year 2022, 2023, 2024.
2. Annual Tax Statements as required by the law on taxation (Tax authorities to certify that the Bidder has submitted its tax statements) for the Year 2022, 2023, 2024.
3. Report on Checking of Bidder's Tax Statements (if any) for the Year 2022, 2023, 2024.

Information provided by:

Name: \_\_\_\_\_

Signature: \_\_\_\_\_

Designation: \_\_\_\_\_

Date: \_\_\_\_\_

Company: \_\_\_\_\_

**PART I: ITB INSTRUCTIONS**

**3. BIDDING FORMS**

*Handwritten initials or signature*

**TENDER ACKNOWLEDGMENT LETTER**

*Letterhead of Bidder*

Date:

To: **DOMESTIC PETROLEUM OPERATING BRANCH - PETROVIETNAM  
EXPLORATION PRODUCTION CORPORATION LIMITED**

Attn: Director

Subject: **TENDER FOR .....**  
**TENDER No. PVEPPOC-.....**

Dear Sir,

- We acknowledge receipt of the subject Invitation to Bid (“ITB”).
- We have received all documents without damage and in usable condition.
- We have read the Instructions to Bidders and will submit a bid in accordance with the Tender requirements.
- We confirm our adherence to the highest standards of business ethics and, in particular, we have established precautions to prevent any of our officers, employees, or agents from making, receiving, providing or offering substantial gifts, entertainment, payment, loans or other considerations which may influence individuals.

**OR**

- We do not wish to bid and therefore we are returning this Tender in its entirety with this Tender Acknowledgement Letter.

All future communications in respect of this ITB should be addressed as follows:

Bidder's

Name:	_____	Telephone:	_____
Attention:	_____	Fax:	_____
Address:	_____	Email:	_____
Signed:	_____		_____
Signature:	_____	Date:	_____
Printed Name:	_____		_____
Title:	_____		_____

**PROPOSAL LETTER FORM**

*Letterhead of BIDDER*

Date:

To           **DOMESTIC PETROLEUM OPERATING BRANCH - PETROVIETNAM  
EXPLORATION PRODUCTION CORPORATION LIMITED**

Attn:        Director

**Subject:     TENDER FOR .....**  
**TENDER No. PVEPPOC-.....**

Dear Sir

We, the undersigned, certify that we have read and understood the subject Invitation to Bid and all documents forming the Bid Document.

We acknowledge that we have thoroughly investigated, or have had the opportunity to do so, and satisfied ourselves as to all conditions affecting the WORKS and all necessary information as to risk contingencies and all circumstances influencing and affecting this Bid Document.

We offer to provide the WORKS as detailed in the Bid Package for the prices stated in our Proposal attached hereto. This offer is valid until **120 days** from the date fixed for submitting same and shall be binding upon us and may be accepted at any time before the aforesaid date.

If our proposal is accepted, we undertake that, unless and until a formal CONTRACT is prepared and executed, this Bid Proposal, together with your written acceptance shall constitute a binding contract between us.

Yours faithfully

Correspondence from CLIENT should be  
addressed to:

Signature :

Address :

Printed Name :

Attn :

Position :

Telephone :

Company:

Telex :

Date :

Fax:

**POWER OF ATTORNEY FORM**

*Letterhead of BIDDER*

Date:

To           **DOMESTIC PETROLEUM OPERATING BRANCH - PETROVIETNAM  
EXPLORATION PRODUCTION CORPORATION LIMITED**

Attn:       **DIRECTOR**

**Subject:    TENDER FOR .....**  
**TENDER No. PVEPPOC-.....**

I, the undersigned - the Legal Representative of .... [Name of BIDDER], hereby authorize and empower [name of Authorized Person and Position] to be my true and lawful attorney to

1.   Signing Proposal Letter;
2.   Signing transaction documents, correspondence with CLIENT during the Bidding Process, including, but not limit to, ITB Clarification Request, Bid Clarification;
3.   Participating in Contract Negotiation and Finalization;
4.   Signing petitions if the BIDDER has any petitions;
5.   Signing contract with CLIENT if we are selected

for [tender title] under the TENDER No. PVEPPOC-.....

This Power of Attorney is effective as from \_\_\_\_\_ to \_\_\_\_\_.

Yours faithfully,

**For and behalf of [name of BIDDER].**

\_\_\_\_\_  
**Name of Legal Representative of BIDDER**

**Position:**

**CONSORTIUM AGREEMENT FORM**

\_\_\_\_\_, Date: \_\_\_\_\_

TENDER: .....

TENDER No. PVEPPOC-.....

We, representatives of the Parties of the Consortium Agreement, including:

Name of the Consortium Partner (Name of Each Consortium Partners) \_\_\_\_\_

Represented by: \_\_\_\_\_

Title: \_\_\_\_\_

Address: \_\_\_\_\_

Power of Attorney No. \_\_\_\_\_ dated \_\_\_\_\_ (in case of authorization).

The Parties (hereinafter referred to as Partners) agreed to enter into this Consortium Agreement with the following terms and conditions:

**Article 1: General Provisions**

1. The Partners are willing to form a Consortium to participate in the Tender No. PVEPPOC-..... for ..... (hereinafter referred to as "TENDER") to DOMESTIC PETROLEUM OPERATING BRANCH - PETROVIETNAM EXPLORATION PRODUCTION CORPORATION LIMITED (hereinafter referred to as "CLIENT").
2. The Partners agree that the name of the Consortium for all correspondences related to TENDER is: \_\_\_\_\_ [specify name of the Consortium as agreed].
3. The Partners confirm that neither of them will unilaterally participate in the bidding of this ITB as an independent Bidder of partner of other consortium. If the consortium is awarded the Contract, neither partner will refuse to execute its obligations and duties as agreed in the Contract unless otherwise agreed in writing by the Consortium Partner. If the Consortium Partner refuses to fulfill its own obligations as agreed then such Partner is to:
  - Compensate for all damages to other Consortium Partners;
  - Compensate for all damages to CLIENT as stipulated in the Contract;
  - Other penalty [specify other penalty].

**Article 2. Responsibilities of the Partners**

The Partners agree that the responsibilities of each Partner for execution of the Tender shall be as follows:

1. Leading Partner of the Consortium:

The Partners agreed to appoint \_\_\_\_\_ [*specify the name of Leading Partner of the Consortium*] to be the Leading Partner of the Consortium to act on behalf of the Consortium in the following works:

- 1.1. Signing Proposal Letter;
  - 1.2. Signing transaction documents, correspondence with CLIENT during the Bidding Process, including, but not limit to, Tender Clarification Request, Bid Clarification;
  - 1.3. Participating in Contract Negotiation and Finalization;
  - 1.4. Signing petitions if the Bidder has any petitions;
  - 1.5. Signing Contract with CLIENT if we are selected
2. The Consortium Partners:  
*[Specify the scope of work, responsibilities of each Partner, including the Leading Partner of the Consortium and, if possible, to specify the percentage of appropriate value].*

**Article 3: Validity of the Consortium Agreement**

1. This Consortium Agreement is valid from the date of signing.
2. This Consortium Agreement will expire in any of the following cases:
  - The Partners completed their obligations, duties and agreed to liquidate the Contract;
  - The Partners agreed to terminate this Agreement;
  - Cancellation of Bidding Process of the Tender according to the notification of CLIENT.

This Consortium Agreement is made in \_\_\_\_ originals, each Partner will keep \_\_\_\_ original(s), all originals are equally valid.

**LEGAL REPRESENTATIVE OF THE LEADING CONSORTIUM PARTNER**

*[Specify full name, title, sign and seal]*

**LEGAL REPRESENTATIVES OF THE CONSORTIUM PARTNERS**

*[Specify full name, title, sign and seal of each Consortium Partner]*

## UNPRICED PROPOSAL FORM

### SCOPE OF WORKS/ SUPPLY

No	Descriptions	UOM	QUANTITY	BIDDER PROPOSAL
1				Bidder to note "Quoted" or "No Quote"
2				
3				
4				
5				

**Note:**

- *The proposed CONTRACT PRICE shall indicate whether it is inclusive of Vietnamese taxes (VAT, CIT, etc.) or not. In the event that the quoted prices do not specify this, they shall be treated as inclusive of all taxes.*
- *Failure to submit this form in accordance with the ITB's requirements may result in the Bidder's proposal being disqualified.*

*Handwritten initials*

**BID BOND FORM**

*Letterhead OF BANK*

BID BOND TO ITB No. PVEP POC-.....

Date: \_\_\_\_\_

To: **DOMESTIC PETROLEUM OPERATING BRANCH - PETROVIETNAM EXPLORATION PRODUCTION CORPORATION LIMITED** (hereinafter referred to as the "CLIENT")

Basing on the fact that \_\_\_\_\_ [*name and registered head office address of the BIDDER*], (hereinafter referred to as "BIDDER"), will participate to the Bidding for your ITB No. PVEPPOC-..... for the [tender title] .....

We \_\_\_\_\_ [*name of the BANK*], having registered office located at \_\_\_\_\_ [*address of registered office of the BANK*] (hereinafter referred to as "BANK"), pledge to BIDDER to secure for the Bidder to participate in bidding for said ITB with an amount of ..... VND (In words: ..... million Vietnam Dong).

We shall immediately transfer to CLIENT the amount of money mentioned above when CLIENT notifies in writing that Bidder breaks the requirements specified in the ITB documents<sup>(1)</sup>.

This Bid Bond is valid for 150 days from the bid's closing date. Any claim of CLIENTY related to this Bid Bond shall be received by [*name of the BANK*] before expiry of above-mentioned validity period.

**Legal Representative of the BANK**

*[Specify name, title, sign and seal]*

Notes:

*(<sup>1</sup>) If the Bidder is a Consortium and the Consortium Partners provide separate Bid Bond or one Consortium Partner provides Bid Bond for the entire Consortium, then this requirement will be amended as follows: "We shall immediately transfer to CLIENT the amount of money mentioned above when CLIENT notifies in writing that BIDDER or any Partner in BIDDER's Consortium breaks the requirements specified in the ITB documents".*

## CURRICULUM VITAE (CV) FOR PROPOSED MANPOWER

1. **Proposed Position** [*only one candidate shall be nominated for each position, one candidate may be nominated for some tasks assigned*]: \_\_\_\_\_
2. **Name of Firm** [*Insert name of firm proposing the staff*]: \_\_\_\_\_
3. **Name of Staff** [*Insert full name*]: \_\_\_\_\_
4. **Date of Birth:** \_\_\_\_\_ **Nationality:** \_\_\_\_\_
5. **Education** [*Indicate college/university and other specialized education of staff member, giving names of institutions, degrees obtained, and dates of obtainment*]: \_\_\_\_\_  
\_\_\_\_\_
6. **Membership of Professional Associations:** \_\_\_\_\_
7. **Other Training** [*Indicate significant training since degrees under 5 - Education were obtained*]: \_\_\_\_\_  
\_\_\_\_\_
8. **Countries of Work Experience:** [*List countries where staff has worked in the last ten years*]: \_\_\_\_\_  
\_\_\_\_\_
9. **Languages** [*For each language indicate proficiency: good, fair, or poor in speaking, reading, and writing*]: \_\_\_\_\_
10. **Employment Record** [*Starting with present position, list in reverse order every employment held by staff member since graduation, giving for each employment (see format here below): dates of employment, name of employing organization, positions held.*]:  
From [Year]: \_\_ To [Year]: \_\_\_\_\_  
Employer: \_\_\_\_\_  
Positions held: \_\_\_\_\_

<p><b>11. Detailed Tasks Assigned</b></p> <p>[<i>List all tasks to be performed under this assignment</i>]</p>	<p><b>12. Work Undertaken that Best Illustrates Capability to Handle the Tasks Assigned</b></p> <p>[<i>Among the assignments in which the staff has been involved, indicate the following information for those assignments that best illustrate staff capability to handle the tasks listed under point 11. <b><u>IT IS IMPORTANT</u></b> that the staff should list <b><u>ALL</u></b> such relevant assignments.</i>]</p> <p>Name of assignment or project: _____</p> <p>Year: _____</p> <p>Location: _____</p> <p>Client: _____</p> <p>Main project features: _____</p> <p>Positions held: _____</p> <p>Activities performed: _____</p>
--	--

H 8

**13. Certification:**

I, the undersigned, certify that to the best of my knowledge and belief, this CV correctly describes myself, my qualifications, and my experience. I understand that any wilful misstatement described herein may lead to my disqualification or dismissal, if engaged.

\_\_\_\_\_ Date: \_\_\_\_\_

*[Signature of staff member or authorized representative of the staff]*      *Day/Month/Year*

Full name of authorized representative: \_\_\_\_\_

**LICENSE FOR SALE OF THE MANUFACTURER FORM**

Date: \_\_\_\_\_

To: **DOMESTIC PETROLEUM OPERATING BRANCH - PETROVIETNAM EXPLORATION PRODUCTION CORPORATION LIMITED** (hereinafter referred to as the "CLIENT")

Dear Sir,

Basing on the request by \_\_\_\_\_ [*name of the BIDDER*] (hereinafter referred to as "BIDDER") who participates in bidding for ITB No. PVEPPOC-..... for the [tender title].

We \_\_\_\_\_ [*name of the MANUFACTURER*], incorporated on \_\_\_\_\_ [*specify the date of incorporation of the Manufacturer*], are producing \_\_\_\_\_ [*list of GOODS to be supplied*] and have registered address at \_\_\_\_\_ [*address of the MANUFACTURER*], hereby authorize BIDDER to use the products manufactured by us to offer in its ITB.

We confirm that we will supply all above GOODS to BIDDER for further supply to CLIENT and provide warranty for the GOODS under the Supply Contract signed between CLIENT and BIDDER.

**Legal Representative of the MANUFACTURER**

[*Specify name, title, sign and seal*]

*[Handwritten initials]*

**BIDDER'S EXCEPTIONS TO TERMS AND CONDITIONS**

<b>ARTICLE NO.</b>	<b>EXACT NEW WORDING PROPOSED BY BIDDER</b>	<b>REASON (S) FOR EXCEPTION</b>	<b>ADDITION (+) OR REDUCTION (-) IN BID PRICE IF EXCEPTION IS ACCEPTED BY CLIENT</b>	<b>EFFECT ON DELIVERY DATE</b>

**ANNEX I. DETAILED PRELIMINARY AND TECHNIAL EVALUATION CRITERIA**

**MOORING HAWSERS AND ACCESSORIES 2026  
RFQ no. PVEPPOC-25-10391**

**1. PRELIMINARY EVALUATION**

The Preliminary Criteria is defined as "MUST" Criteria. Therefore, Non-compliance / deviations / exceptions to any of these criteria will cause the Bid disqualified without clarification. Bidders will be requested to comply with the requirements.

The Bids shall be evaluated with the following Essential Criteria:

No.	Criteria	Bidder		
		A	B	C
1	Place and time of Bid submission			
2	Eligibility of Bidder			
3	Original Bid Proposal			
4	Eligibility of Partnership agreements (pursuant to Article 8.3, Section 1)			
5	Eligibility of Proposal Letter			
6	Validity of Bid Proposal			
7	Original Bid Bond			
8	Financial Capacity (detail in Table 1-A)			
	Final Assessment			

Note: These above requirements are evaluated according to "qualified or disqualified" as result.

- "Qualified": meet all requirements
- "Disqualified": not meet any of these above requirements

**Table 1-A: Financial Capacity:**

Financial Capacity Criteria	Requirement (%) in at least one of three last years	2022 (%)	2023 (%)	2024 (%)
1. Current Ratio (%)	> 100%			
2. Net profit margin (%)	> 0%			

The essential criteria will be categorized under "ACCEPTABLE" or "NOT ACCEPTABLE" only.

Any Bid which passed Preliminary Evaluation shall be accepted to Technical Evaluation.

**2. TECHNICAL EVALUATION**

**TECHNICAL EVALUATION CRITERIA**

**Technical Requirements and Evaluation criteria:**

Item	Evaluation	Criteria	Assessment		
			A	AC	NA
1	Quantity of each item (as Exhibit I-Scope of Supply).	Major	X		X
2	Technical specification of goods (as Exhibit I-Scope of Supply).	Major	X		X
3	Tolerance of the hole's diameter of tubular thimble – Bidder confirms (as Exhibit I-Scope of Supply).	Minor	-/+ 0%	-1% / 0%	Out of this range -1% / 0%
4	Document and Certificate for Goods (as Exhibit I-Scope of Supply).	Major	X		X
5	Year of production (as Exhibit I-Scope of Supply).	Major	X		X
6	Country of origin (as Exhibit I-Scope of Supply).	Major	X		X
7	Delivery time (30 weeks)	Major	X		X

**A**  
**AC**  
**NA**

- Technically Acceptable (applied to Major Evaluation Criteria Categories)
- Technically Acceptable with Concerns (applied to Minor Evaluation Criteria Categories only)
- Technically Not Acceptable (applied to Major and Minor Evaluation Criteria Categories)
- Proposals are considered Technical Acceptable if all items are marked with "A" or "AC".
- Proposals are considered Technical Not Acceptable if at least one item is marked with "NA".



**CONTRACT**

**Between**

**DOMESTIC PETROLEUM OPERATING BRANCH - PETROVIETNAM  
EXPLORATION PRODUCTION CORPORATION LIMITED**

**And**

.....

**For**

.....

**CONTRACT No.: PVEPPOC-.....**

**TABLE OF CONTENTS**

**ARTICLE. TITLE**

PREAMBLE ..... 4

ARTICLE 1 – INTERPRETATION OF CONTRACT ..... 4

ARTICLE 2 - DEFINITIONS..... 6

ARTICLE 3 - FORM OF CONTRACT ..... 7

ARTICLE 4 - GOODS, QUANTITY AND SPECIFICATIONS..... 7

ARTICLE 5 - CONTRACT PRICE..... 7

ARTICLE 6 - DELIVERY ..... 8

ARTICLE 7 - NOTICE OF DELIVERY, SHIPPING DOCUMENTS, PACKING AND MARKING  
..... 8

ARTICLE 8 - PASSING OF TITLE AND CONTRACTOR'S RISK..... 9

ARTICLE 9 - ACCEPTANCE OF GOODS ..... 9

ARTICLE 10 - INVOICING AND PAYMENT ..... 10

ARTICLE 11 - TAX AND DUTY ..... 12

ARTICLE 12 - INSURANCE..... 12

ARTICLE 13 - ACCESS AND AUDIT ..... 12

ARTICLE 14 - CONFIDENTIALITY ..... 13

ARTICLE 15 - SUSPENSION ..... 13

ARTICLE 16 - TERMINATION..... 13

ARTICLE 17 - WARRANTY ..... 14

ARTICLE 18 - ENGINEERING CODES AND STANDARDS ..... 16

ARTICLE 19 - MANUFACTURING CHANGES ..... 16

ARTICLE 20 - PATENT INDEMNITY ..... 16

ARTICLE 21 - LIABILITIES AND INDEMNITY ..... 16

ARTICLE 22 - LIMITATION OF LIABILITY ..... 17

ARTICLE 23 - LIENS AND CLAIMS ..... 17

ARTICLE 24 - FORCE MAJEURE ..... 17

ARTICLE 25 - HEALTH, SAFETY AND ENVIRONMENT (“HSE”)..... 17

ARTICLE 26 – ASSIGNMENT AND SUBCONTRACT ..... 17

ARTICLE 27 - VENDOR DATA REQUIREMENTS AND SUBMITTAL ..... 18

ARTICLE 28 - EXPEDITING..... 18

ARTICLE 29 - INSPECTION ..... 18

ARTICLE 30 - LIQUIDATED DAMAGES ..... 19

ARTICLE 31 - BANK GUARANTEE..... 19

ARTICLE 32 - APPLICABLE LAW AND ARBITRATION ..... 20

ARTICLE 33 - LANGUAGE .....20  
ARTICLE 34 - NON-EXCLUSIVE AGREEMENT.....20  
ARTICLE 35 - ENTIRE AGREEMENT.....20

**EXHIBITS**

EXHIBIT I SCOPE OF SUPPLY AND TECHNICAL REQUIREMENTS  
EXHIBIT II CONTRACT PRICE  
EXHIBIT III SHIPPING DOCUMENT, PACKING AND MARKING REQUIREMENT  
EXHIBIT IV FORM OF BANK GUARANTEE  
EXHIBIT V FORM OF ACCEPTANCE PROTOCOL  
EXHIBIT VI FORM OF CONTRACT CLOSURE CERTIFICATE

A 8

**PREAMBLE**

This CONTRACT (hereinafter referred to as "CONTRACT") is made and entered into this \_\_\_\_\_ day of \_\_\_\_\_ 2026 ("Contract Signing Date") effective as of the \_\_\_\_\_ day of \_\_\_\_\_ 2026 ("Effective Date") between

**DOMESTIC PETROLEUM OPERATING BRANCH - PETROVIETNAM EXPLORATION PRODUCTION CORPORATION LIMITED**, a company organized and existing under the Laws of S.R Vietnam and having its registered address at 15<sup>th</sup> Floor, Victory Tower, 12 Tan Trao Street, Tan My Ward, Ho Chi Minh City, S.R. Vietnam, (hereinafter referred to as "CLIENT") of the first part;

And

\_\_\_\_\_ a company incorporated under the laws of \_\_\_\_\_ having its registered office at \_\_\_\_\_ (hereinafter referred to as "CONTRACTOR") of the second part.

Hereinafter the parties of the first and second parts shall be referred to singularly as "Party" and collectively as "Parties".

**WHEREAS:** CLIENT is appointed as Authorized Operator’s Attorney for the exploration, development and production of hydrocarbons for oil and gas fields offshore Vietnam;

**WHEREAS:** CLIENT requires the **MOORING HAWSERS AND ACCESSORIES 2026** (hereinafter referred to as the "GOODS") as described in the **EXHIBITS** (attached hereto and made a part hereof) and in accordance with the terms of this CONTRACT;

**WHEREAS:** CONTRACTOR represents that it is able and willing to supply the aforementioned GOODS and that it has the experience and capability to do so expeditiously.

NOW, THEREFORE, for and in consideration of the mutual covenants and agreements set forth herein, the Parties hereto agree as follows:

**ARTICLE 1 – INTERPRETATION OF CONTRACT**

1.1 The following documents together constitute this CONTRACT:

CONTRACT FORM

- EXHIBIT I SCOPE OF SUPPLY AND TECHNICAL REQUIREMENTS
- EXHIBIT II CONTRACT PRICE
- EXHIBIT III SHIPPING DOCUMENT, PACKING AND MARKING REQUIREME
- EXHIBIT IV FORM OF BANK GUARANTEE
- EXHIBIT V FORM OF ACCEPTANCE PROTOCOL
- EXHIBIT VI CONTRACT CLOSURE CERTIFICATE

## 1.2 Interpretation and Significance of Expressions

- a) In the event of ambiguity, inconsistency or conflict between the provisions of the CONTRACT and the Exhibits listed above, the CONTRACT shall prevail and precede over the Exhibits. In the event of disagreement between the Specification and drawing, the Specification shall be decisive.
  - b) In the event of ambiguity, inconsistency or conflict between the provisions of the Exhibits, CLIENT Representative shall have the discretion to decide the order of prevalence amongst the Exhibits.
  - c) Any reference to statute, statutory provision or statutory instrument shall include any re-enactment or amendment thereof for the time being in force.
  - d) All headings to the Articles of the CONTRACT are inserted for convenience of reference only and shall not affect the construction or interpretation of this CONTRACT.
  - e) At anytime and unless expressly stated otherwise, when the following expressions and description and derivatives thereof appear in the CONTRACT, their connotations shall be extended or limited as set out as follows:
    - "including", "included", "such as", "comprising", "comprise" and the like shall be deemed to be completed by the expression "but not limited to".
    - "require", "request", "submit", "answer", "notify", "instruct", "state", "inform", "agree", "approve", "advise" and the like shall be deemed to be completed by the expression "in writing".
    - "days" shall mean "consecutive calendar days", it being understood that all dates and time periods referred to in the CONTRACT relate to Gregorian calendar.
  - f) Where the context so requires, the singular includes the plural and vice versa and words of one gender include all genders.
  - e) Headings and table of contents are inserted only for convenience and shall not in any way limit or govern the construction of the CONTRACT.
- 1.3 Any references or details provided in any one of the above documents but not in others shall be taken as read in all documents in this CONTRACT.
- 1.4. (a) All Standards, Codes, Specifications, Drawings, Instructions and other documents that are referred to in the Exhibits are deemed as incorporated by reference and made a part of the CONTRACT. CONTRACTOR shall immediately notify CLIENT of ambiguity, inconsistency or conflict between any of these documents. CLIENT will then issue instruction regarding these documents. Otherwise, the Articles of the CONTRACT shall take precedence in the event of ambiguity or it being in conflict or inconsistent with any other referred document.
- (b) Should CONTRACTOR fail to give notice to CLIENT or fail to discover such ambiguity, inconsistency or conflict in the aforementioned documents as should have been discovered by CONTRACTOR, all extra costs resulting from such failure shall be

borne by the CONTRACTOR, except when it was caused solely by negligence of CLIENT.

- 1.5 None of the documents herein before mentioned shall be used by CONTRACTOR for any purpose other than for this CONTRACT.

## **ARTICLE 2 - DEFINITIONS**

- 2.1 "AFFILIATES" means any CLIENT which controls, or is controlled by, or which is controlled by an entity, which controls, a Party. For the purposes of this definition, "control" means the ownership directly or indirectly of more than fifty (50%) percent of the voting rights in a CLIENT.
- 2.2 "GOODS" means materials or products or goods to be purchased or to be supplied as specified in the CONTRACT.
- 2.3 "CLIENT" means PETROVIETNAM Domestic Exploration Production Company Limited or any its divisions, AFFILIATES so named in the CONTRACT.
- 2.4 "CONTRACT" means the CONTRACT document and any other documents listed herein and shall constitute the entire agreement between the Parties and the appendices as may be amended by any special conditions referred to in the CONTRACT.
- 2.5 "CONTRACT PRICE" means the Price payable to CONTRACTOR as specified in the Article headed CONTRACT PRICE.
- 2.6 "Country of Origin" means the place where the GOODS were mined, grown, cultivated, produced, manufactured or where GOODS and its parts are processed, assembled, further manufactured to have a merchantable product that has substantial differentiation from the components from which it is composed.
- 2.7 "Day" means calendar day.
- 2.8 "Delivery Date" means the date a clean Bill of Lading or Air Way Bill for GOODS shipment.
- 2.9 "Delivery Time" means the time required by CONTRACT to deliver GOODS as stipulated in the Article headed Delivery.
- 2.10 "Incoterms": unless inconsistent with any provision of the contract where that provision of the contract shall prevail, the meaning of any trade term, for example EXW, FOB, CIF, CFR, DAP and the rights and obligations of parties thereunder shall be as prescribed by Incoterms version 2020 published by the International Chamber of Commerce in Paris, France.
- 2.11 "Liquidated Damage" is the sum which party to CONTRACT agrees to pay if a Party breaks particular promise and, which having been arrived at by good faith effort to estimate actual damage that shall probably ensue from breach, is recoverable as agreed damages if break occurs.
- 2.12 "SPECIFICATIONS" means the specifications of GOODS attached to the CONTRACT; the specifications also include the inspection method of GOODS and packing standards, the specifications shall constitute an integral part of the CONTRACT.

- 2.13 "CONTRACTOR" means the person(s), firm, company or entities named in the CONTRACTOR to supply GOODS hereinafter defined and shall include the CONTRACTOR's legal personal representatives, successors and assignees.
- 2.14 "SERVICES" means all works, services and obligations to be performed, provided or otherwise fulfilled by CONTRACTOR pursuant to and in accordance with the Terms and Conditions of the CONTRACT, including without limitation the work and services described in the CONTRACT, together with any operations carried out in connection therewith, and the physical result of the performance of such work, services and obligations.

### **ARTICLE 3 - FORM OF CONTRACT**

- 3.1 CLIENT shall not be liable for any orders or amendments other than those issued or confirmed on this CONTRACT and any amendment thereto.
- 3.2 CLIENT may make changes in the SPECIFICATIONS or drawings, including additions to or deletions from the quantities of GOODS originally ordered. If any such changes affect the amount due and/or the time of performance hereunder, an equitable adjustment shall be made as mutually agreed by CLIENT and CONTRACTOR to the amount due and/or the time of performance, as the case may be by the issuance of CLIENT's Change Order.
- 3.3 Authorized Change Order requests made after Effective Date of CONTRACT shall be priced properly justified and immediately submitted to CLIENT for approval. CLIENT reserves the right to accept or reject any or all requests.

### **ARTICLE 4 - GOODS, QUANTITY AND SPECIFICATIONS**

- 4.1 CONTRACTOR shall supply the GOODS to CLIENT with SPECIFICATIONS, quantity, unit as described in Exhibit I attached hereto, which forms an integral part of this CONTRACT.
- 4.2 The GOODS shall be brand new, fully meet all specifications and requirements as stated in Exhibit I, and conform to quality standards of relevant Manufacturers, when no applicable standard is mentioned, the appropriate official standards of the Country of Origin shall be applicable.
- 4.3 Manufacturer and Country of Origin: as requested in Exhibit I.
- 4.4 Within three (3) weeks from the Effective Date, CONTRACTOR shall submit the Production Schedule by email and/or courier to CLIENT (This provision applicable to "Make to Order/ MTO GOODS").

### **ARTICLE 5 - CONTRACT PRICE**

- 5.1 The CONTRACT PRICE shall be VND \_\_\_\_\_ (In words: \_\_\_\_\_ only) which shall be detailed in accordance with Exhibit II of this CONTRACT.

5.2 The CONTRACT PRICE referred to in this Article shall be understood DAP CLIENT's warehouse, PTSC Downstream Port, Vung Tau, S.R. Vietnam - INCOTERMS 2020, unless otherwise expressly stipulated in this CONTRACT, including without limitation the value of the GOODS, charges of marking and packing, transportation cost, technical documentation, expenses for test and inspection performed by CONTRACTOR or its manufacturer prior to shipment and obtaining necessary certificates and licenses, warranty services (if any) and all taxes, duties and other expenses in connection with the execution of this CONTRACT outside the CLIENT's country.

The price is fixed and not subject to change for the whole term of the CONTRACT, with the exception of any price adjustments authorized in the Contract.

#### **ARTICLE 6 - DELIVERY**

6.1 Time is of the essence for the delivery of GOODS specified under the CONTRACT. CONTRACTOR shall give written notice to CLIENT of any anticipated delay. In case of actual or anticipated delay, CLIENT may terminate the CONTRACT in a manner specified in the Article headed TERMINATION.

6.2 Unless otherwise provided herein, the delivery of GOODS shall be governed and/or construed in accordance with the provision of Incoterms 2020, ICC and any amendments thereto.

6.3 The Commodity supplied under this CONTRACT shall be delivered in accordance with Exhibit I

6.4 Delivery Schedule shall be as per Exhibit I.

Earlier delivery is desired.

Partial delivery may be allowed subject to the provisions in Exhibit I of this Contract.

6.5 CONTRACTOR shall be responsible for and bear all risks and relevant costs and damages and/ or losses caused to CLIENT arising out of or relating to CONTRACTOR's sending GOODS to the wrong destination.

CONTRACTOR shall be responsible for any incremental installation cost and/ or transportation cost and/ or any other reasonable cost/ expenses resulting from late delivery.

#### **ARTICLE 7 - NOTICE OF DELIVERY, SHIPPING DOCUMENTS, PACKING AND MARKING**

7.1 Immediately but not later than four (4) days after the Delivery Date, CONTRACTOR shall send the Shipping Documents as stipulated in Exhibit III of this CONTRACT in English language to CLIENT by Express Courier at the CONTRACTOR's expenses.

At the same time, CONTRACTOR shall also advise CLIENT of the following information to enable CLIENT to carry out customs procedures for import of the shipped GOODS:

(a) CONTRACT number and GOODS description;

(b) Number of packages;

(c) Weight and dimension of each package;

(d) Vessel's name (Carrier/Flight Number for air freight) estimated time of departure (ETD) from port/ airport of export and estimated time of arrival (ETA) at port/ airport of discharge.

(e) Other necessary information.

- 7.2 Within two (2) days before the Delivery Time as specified in Article headed Delivery, CONTRACTOR shall send the written Delivery Notice in which shall be specified the information as requested in Article 7.1 hereof.
- 7.3 GOODS shall be packed, marked and delivered in original and standard packing for export and suitable for the nature of GOODS and transportation in accordance with Packing and Marking Requirement as stipulated in Exhibit III of this CONTRACT.

#### **ARTICLE 8 - PASSING OF TITLE AND CONTRACTOR'S RISK**

##### **8.1 Receipt and When GOODS are delivered.**

GOODS shall be deemed delivered upon signing by CLIENT and CONTRACTOR of an Acceptance Protocol in accordance with the Article headed Acceptance of GOODS.

##### **8.2 Passing of Title and Risk**

GOODS shall remain at CONTRACTOR's risk until GOODS shall be delivered as stipulated in this Article 8.

Property and Title in GOODS shall be passed to CLIENT when the GOODS are delivered stipulated in this Article 8, unless otherwise agreed in this CONTRACT.

#### **ARTICLE 9 - ACCEPTANCE OF GOODS**

- 9.1 CLIENT or its duly appointed representative shall have the right to inspect and if necessary to reject and to request for replacement of GOODS or parts thereof which do not comply with the CONTRACT.
- 9.2 In the case of GOODS or parts thereof delivered by CONTRACTOR not in conformity with the CONTRACT, whether by reason of not being the quality or not in the quantity or measurements stipulated or being unfit for the purpose for which they are required where such purpose has been made known to CONTRACTOR or not meeting the requirement of Shipping Documents as stipulated under the CONTRACT, CLIENT shall have the right to reject or not to accept such GOODS, request SUPPLIER to repair or replace such GOODS; supply any shortfall in the event of shortfall in delivery and to purchase. CONTRACTOR shall bear all expenses incurred by either CONTRACTOR or CLIENT as a result of the rejection, repair or replacement of GOODS or supply of shortfall in delivery including but not limited to cost of transportation and customs duties.
- 9.3 In case of partial delivery, any delay or failure to comply with the Contractual Delivery Date(s) shall be deemed a breach of the CONTRACT and CLIENT reserves the right to terminate CONTRACT or refuse to accept GOODS respectively.

F 8

9.4 Where CLIENT or its appointed party makes an inspection of a representative sample of GOODS not in accordance with the SPECIFICATIONS in the respective sample, CONTRACTOR shall bear the additional cost of inspecting the whole of GOODS supplied to ascertain their quality or quantity or measurement stipulated or being fit for the purpose of which they are required.

9.5 Acceptance Protocol

Upon arrival of GOODS at the place of delivery in accordance with the Article headed as DELIVERY, within 03 (three) days after receiving the notice from CLIENT (by fax), CONTRACTOR shall, at its own cost, arrange and assign an authorized representative to be present at CLIENT's warehouse to assist CLIENT in becoming familiar with the operation of the GOODS during the period of inspection prior to acceptance of GOODS. However, CLIENT's performance shall not release CONTRACTOR from its obligations and responsibilities under CONTRACT, including without limitation CONTRACTOR's warranty obligations.

Upon completion of the inspection prior to acceptance of GOODS, CLIENT shall issue an Acceptance Protocol in accordance with Exhibit V of this CONTRACT which will be duly signed by authorized representatives of both Parties and the third party for handover of GOODS. All costs, expense of the trip and stay of the CONTRACTOR's representative shall be at the CONTRACTOR's account.

Should any GOODS fail to past inspection prior to acceptance of GOODS, CLIENT may reject such defective GOODS, in whole or in part, and CONTRACTOR shall immediately either replace the rejected GOODS or make alterations necessary to meet specifications and requirements under CONTRACT free of charge to CLIENT.

Both Parties shall agree that the Acceptance Protocol shall be final and binding evidence regarding the quantity, quality and status of GOODS for CLIENT to make payment to the CONTRACTOR under this CONTRACT and CONTRACTOR hereby agree to make no claim or any similar request to CLIENT for any payment which is not supported or substantiated by the Acceptance Protocol. However, the issuance of the said Acceptance Protocol itself shall not in any way release CONTRACTOR from any of its obligations under this CONTRACT, including without limitation CONTRACTOR's warranty obligations.

**ARTICLE 10 - INVOICING AND PAYMENT**

10.1 CONTRACTOR's invoice(s) shall not be submitted until the GOODS are due and have been delivered and accepted by CLIENT. Unless otherwise stated in CONTRACT, payment shall be made by 100% T/T (Telegraphic Transfer) within forty-five (45) days following receipt of CONTRACTOR's undisputed invoice and all necessary supporting documents. If the forty fifth (45) day falls on a Saturday or Sunday or a gazetted S.R. Vietnam public holiday, the next working day shall be deemed to be the due date of payment.

10.2 Invoices shall indicate CONTRACT number and title and shall be submitted in one (1) original and two (2) copies complete with the necessary documentation required by COMPANY and shall be addressed to:

**DOMESTIC PETROLEUM OPERATING BRANCH - PETROVIETNAM  
EXPLORATION PRODUCTION CORPORATION LIMITED**

15<sup>th</sup> Floor Victory Tower

12 Tan Trao Street, Tan My Ward,

Ho Chi Minh City, S.R Vietnam

Tel: (84-28) 5416 5050 Fax: (84-28) 5416 0616

Attn: **Manager, Finance & Accounts**

E-invoices (if any) shall be submitted with the invoice link to the email address below:

EMAIL: [poc.invoice@pvep.com.vn](mailto:poc.invoice@pvep.com.vn)

Company Name and VAT Code:

CHI NHÁNH ĐIỀU HÀNH DẦU KHÍ TRONG NƯỚC – CÔNG TY TNHH – TCT THẨM  
DÒ KHAI THÁC DẦU KHÍ – LÔ 05.1A

Tầng 15, Tòa nhà Victory, số 12 Tân Trào, P. Tân Mỹ, Tp HCM

MST: 3502205616

10.3 Payments in respect of disputed items may be withheld by CLIENT until the settlement of the dispute by mutual agreement. Payments made by CLIENT shall not preclude the right of CLIENT to thereafter dispute any of the items invoiced.

10.4 In the event that CLIENT disputes any items on a particular invoice, CLIENT shall only be entitled to withhold from payment the actual amount in dispute. If CLIENT disputes any items on an invoice, CLIENT shall inform CONTRACTOR of the disputed item within thirty (30) days of the receipt by CLIENT of that particular invoice.

10.5 CLIENT shall be entitled to withhold payment if any of CONTRACTOR's invoices which do not include sufficient supporting documentation required by CLIENT. In any case, Bank Guarantee as required under Article 31 - Bank guarantee (if applicable) shall be included in the supporting documentation.

10.6 All payments to CONTRACTOR shall be made to:

Bank Name :

Account No. :

CONTRACTOR shall advise CLIENT on its account details and/or any changes to its account details if any by an at least 15 days in advance notice. Should CONTRACTOR fail to give such notice in due time to CLIENT, CONTRACTOR shall bear all risks associated with wrong/incorrect money transfer made by CLIENT.

10.7 Within forty-five (45) days from CONTRACTOR's invoice shall fully be paid by CLIENT to CONTRACTOR, CONTRACTOR shall provide CLIENT with CONTRACT Closure Certificate as per format in the EXHIBIT VI of this CONTRACT to the date of such

✶ 8

statements in connection with GOODS have been fully received and finally paid by CLIENT to CONTRACTOR.

- 10.8 All payments to Domestic CONTRACTOR by CLIENT under the terms of this CONTRACT shall be made in Vietnam Dong (VND), except for payments for WORKS performed by Foreign CONTRACTOR's Sub-contractor/Parent Company/Subsidiary/Affiliate which is made in United State Dollar (USD) to such Foreign CONTRACTOR's Sub-contractor/Parent Company/Subsidiary/Affiliate by CONTRACTOR which shall be back-to-back made to CONTRACTOR by CLIENT in USD provided that CONTRACTOR shall provide CLIENT with all necessary supporting documents for such payment in USD, including but not limitation to a contract, custom declaration, invoice, etc. All payments to Foreign CONTRACTOR by CLIENT under the terms of this CONTRACT shall be made in US Dollar (USD). The exchange rate to be used to convert shall be the transfer rate (Buy) for VND and USD announced by the Bank for Foreign Trade of Vietnam (Vietcombank) at the time of VAT invoice issuance shall be applied.

#### **ARTICLE 11 - TAX AND DUTY**

- 11.1 CONTRACTOR shall be entirely responsible for all taxes, duties, export license fees (if any), customs fees imposed on the CONTRACTOR other than Vietnam in connection with the performance of CONTRACT. CONTRACTOR shall indemnify and keep harmless CLIENT from any and all claims and liabilities arising from its non-compliance with this Article 11.1.
- 11.2 CLIENT shall pay and shall be responsible for all taxes, duties and fees imposed on CLIENT's country in connection with the performance of CONTRACT. CLIENT shall indemnify and keep harmless CONTRACTOR from any and all claims and liabilities arising from its non-compliance with this Article 11.2.

#### **ARTICLE 12 - INSURANCE**

CONTRACTOR at its own cost, shall insure GOODS supplied under this CONTRACT for each shipment in the currency stated in the CONTRACT covering All Risk Clause with a reputable insurance company in an amount of 125% of CIF value of the GOODS.

Notwithstanding anything to the contrary herein, CONTRACTOR shall bear the risks to GOODS until such GOODS is handed over to CLIENT in accordance with the Article headed Passing of Title and CONTRACTOR's Risk.

With respect to GOODS to which the ownership rights must, as provided for by law, be registered, CONTRACTOR shall bear risks to such GOODS until the registration procedures are completed or until such GOODS is handed over to CLIENT in accordance with Article headed Passing of Title and CONTRACTOR's Risk, whichever is later.

#### **ARTICLE 13 - ACCESS AND AUDIT**

- 13.1 CLIENT shall have the right to expedite and inspect the GOODS at any time and/or audit all

CONTRACTOR's documents and records related to this CONTRACT. Such right shall remain in full force until up to three (03) years after expiry or termination of this CONTRACT.

13.2 CONTRACTOR shall permit at its work sites and at the work sites of any of its Sub-CONTRACTOR such as expediting and inspection surveillance as is considered necessary by CLIENT. Any such expediting, inspection or any failure to do so shall in no way relieve CLIENT of his obligations under the CONTRACT.

#### **ARTICLE 14 - CONFIDENTIALITY**

CONTRACT shall be treated as confidential, and CONTRACTOR shall not make use of CLIENT's name or the name of any company or companies associated with CLIENT for publicity purposes without prior written consent of CLIENT. Furthermore, all designs, drawings, specifications and information that may be supplied in connection with this CONTRACT are confidential and must only be used for the purpose of this CONTRACT. No public statements, announcements or circulars regarding this CONTRACT or the activities of the Parties relating thereto shall be made or issued by or on behalf of CONTRACTOR without the prior written approval of CLIENT.

#### **ARTICLE 15 - SUSPENSION**

CLIENT shall have the right to suspend the CONTRACT for the following reasons:

- (a) Force Majeure in accordance with the Article headed Force Majeure;
- (b) In the event of any complete or partial stoppage of CLIENT projects;
- (c) Failure on part of CONTRACTOR to perform any obligation under CONTRACT.

Such suspension shall remain in force until the time that the above reasons are no longer applicable or otherwise when waived in writing by CLIENT.

#### **ARTICLE 16 - TERMINATION**

16.1 CLIENT may terminate the CONTRACT at any time by giving written notice to CONTRACTOR. Upon receipt of such notice, CONTRACTOR shall cease supply of GOODS and CLIENT shall pay CONTRACTOR a fair price with proper supporting evidence for any GOODS delivered at the date when such notice is given.

In case of such termination, CONTRACTOR shall

- (i) use its best endeavors to affect the immediate cancellation of orders which it may have placed with others and discontinue all works of manufacturing GOODS, and
- (ii) upon CLIENT's request, deliver to CLIENT any or all the work, drawings, SPECIFICATIONS, data sheet and other matters that CONTRACTOR may have prepared for GOODS and all materials, supplies and equipment paid for by CLIENT either directly or in directly, and CLIENT shall have the right to make use of same for

such purposes as CLIENT may desire, and

(iii) Not be entitled to any prospective profits or incidental, indirect, consequential or other damages because of termination.

16.2 In the event the CLIENT terminates the CONTRACT in whole or in part in any of the following cases:

(i) CONTRACTOR's failure to deliver GOODS by the time as specified in the Article headed DELIVERY;

(ii) CONTRACTOR's failure to replace and/ or make good the defective GOODS as specified in the Article headed Acceptance of GOODS;

(iii) CONTRACTOR's failure to perform or to comply with any other obligations under CONTRACT;

CLIENT may, at its own discretion and as it deems fit, forfeited the Bank Guarantee, correct such CONTRACTOR's breach by purchasing new GOODS, making good the defective GOODS by services of a third party, or otherwise and all cost and expense arising therefrom shall be at CONTRACTOR's account. In addition, CONTRACTOR shall compensate CLIENT for all losses and/or damages arising from such CONTRACTOR's breach of CONTRACT and shall pay to CLIENT a penalty of eight per cent (8%) of the value of the whole or the part of the CONTRACT so terminated. Payment for all these costs, expense, compensation and penalty if any shall be made to CLIENT within 10 (ten) days of CONTRACTOR's receipt of CLIENT's first written request.

16.3 In the event the CLIENT terminates the CONTRACT in whole or in part pursuant to CONTRACTOR's failure to submit the Bank Guarantee on schedule in accordance with the Article headed as Bank Guarantee, CONTRACTOR shall pay to CLIENT a penalty of eight per cent (8%) of the value of the whole or the part of CONTRACT so terminated within 10 (ten) days of CONTRACTOR's receipt of CLIENT's first written request.

## **ARTICLE 17 - WARRANTY**

17.1 CONTRACTOR warrants that the GOODS supplied under this CONTRACT are new, unused, of the most recent or current models, and are fully in compliance with all specifications and requirements of this CONTRACT and that they incorporate all recent improvements in design and materials unless provided otherwise in the CONTRACT. CONTRACTOR further warrants that all GOODS supplied under this CONTRACT shall have no defect, arising from design, materials, or workmanship or from any act or omission of the CONTRACTOR that may develop under normal use of the supplied GOODS in the conditions prevailing in the Country of CLIENT.

17.2 CONTRACTOR warrants for normal operation of the GOODS for 18 months from date of delivery or 12 months after installation whichever is earlier (original).

17.3 Should any shortage, defects (whether latent or apparent) be revealed, or should the quality of the GOODS not conform to the technical standards and SPECIFICATIONS under this

CONTRACT, CLIENT shall have the right to make claim to CONTRACTOR. CLIENT shall notify the CONTRACTOR of its claim in writing arising under this warranty.

- 17.4 Within fifteen (15) days from CONTRACTOR's receipt of CLIENT's claim (excluding the normal time for transportation of replacement parts), CONTRACTOR shall replace and/or make good the defective GOODS or parts thereof without any cost to CLIENT. CONTRACTOR shall ensure that the replaced and/or repaired GOODS shall meet all SPECIFICATIONS and requirements of this CONTRACT and CONTRACTOR shall give a warranty for normal operation of the replaced GOODS/parts for twelve (12) months from the date of replacement.
- 17.5 In the case of CONTRACTOR's not in agreement with CLIENT's claim, CONTRACTOR must notify CLIENT of its disagreement within five (5) days of CONTRACTOR's receipt of CLIENT's claim and failing such notification CONTRACTOR shall be deemed to have accepted CLIENT's claim. In the case of the CONTRACTOR's disagreement, CLIENT may invite an independent inspection organization to carry out the inspection and notify CONTRACTOR of the time and name of the independent inspection organization. CONTRACTOR may, at its own cost and in its discretion, participate in the inspection. The report issued by the said inspection organization shall be the conclusive, final, sufficient and legal evidence to substantiate CLIENT's claim (regardless of CONTRACTOR's participation in the inspection or not). If, after the inspection report is made and it is found that the causes of the defect are those other than CLIENT's mistake in operation, then Article 17.4 above shall apply and the date of issuance of the inspection report shall be deemed the date of CONTRACTOR's receipt of CLIENT's claim. The cost of this inspection shall be at CONTRACTOR's expense.
- 17.6 Should CONTRACTOR fail to deliver the replacements for the defective GOODS and/or fail to make good the defects thereof within the above stipulated time in accordance with Article 17.4 above, CLIENT will have the right, at its own discretion, to make good the defect or replace the defective GOODS with new ones from a third party, and CONTRACTOR undertakes to immediately reimburse CLIENT at CLIENT's first request for all actual relevant cost and expenses arising therefrom.
- 17.7 The claim of latent defects or non-conformity of GOODS shall be submitted to the CONTRACTOR not later than thirty (30) days after the expiration of the warranty period. No claim shall be submitted later than thirty (30) days after the expiration of the Warranty Period.
- 17.8 When the replacement or repair (if any) has been made and all related costs, expenses, damages, agreed and liquidated damages have been settled, CLIENT's claim is to be considered finally settled.
- 17.9 All the claim amount, for which the CONTRACTOR is responsible to CLIENT under this CONTRACT, shall be paid by telegraphic transfer not later than ten (10) days upon the date of CLIENT's claim telex/telefax or may be deducted from the payment to CONTRACTOR under this Contract or finally settled by Arbitration as per provisions of this CONTRACT.
- 17.10 Nothing in this Article 17 shall deprive CLIENT of its right for compensation and/or penalty

as stipulated in Articles headed as Liquidated Damages.

#### **ARTICLE 18 - ENGINEERING CODES AND STANDARDS**

The codes and standards which apply to GOODS covered by this CONTRACT are listed in the SPECIFICATIONS. These codes and standards may be revised from time to time, and it shall be the CONTRACTOR's responsibility to ensure that the latest revisions to these codes and standards are being adhered to. Any difference in these codes and standards and revisions shall be immediately notified in writing to CLIENT.

#### **ARTICLE 19 - MANUFACTURING CHANGES**

CLIENT shall be advised of all changes in the SPECIFICATIONS or method of construction of GOODS supplied before such changes are implemented. In the event of CLIENT accepting the change, written approval shall be sent to CONTRACTOR.

#### **ARTICLE 20 - PATENT INDEMNITY**

- 20.1 CONTRACTOR shall indemnify CLIENT against any claim of infringement of patents, registered designs or other rights which arise as a result of the sale or use of GOODS supplied by CONTRACTOR. This indemnity shall not extend to instances in which GOODS concerned have been supplied to the design of CLIENT.
- 20.2 CONTRACTOR is obliged to secure that the ownership rights to GOODS are not disputed by a third party. In case there is any dispute by a third party, CONTRACTOR shall take side with CLIENT in order to protect CLIENT's interests. If the third party is entitled to own part or the whole of GOODS, CLIENT shall be entitled to cancel the CONTRACT and CONTRACT shall compensate CLIENT for all damage including, but not limited to the refund of CONTRACT PRICE, liquidated damage, legal cost, and attorney fees.

#### **ARTICLE 21 - LIABILITIES AND INDEMNITY**

- 21.1 CONTRACTOR shall be responsible and shall protect, indemnify and save CLIENT harmless from and against any claims, demands and causes of action for damage to any property as well as death of or personnel injury to any person arising out of the act or omission to act, negligent or otherwise, of CONTRACTOR, CONTRACTOR's employees and CONTRACTOR's agents. CONTRACTOR shall carry and maintain all applicable insurance as required by law and this CONTRACT.
- 21.2 CONTRACTOR shall be liable for, indemnify and hold CLIENT (including CLIENT's officers, directors employees or agents), harmless from all damages, claims, losses, expenses and/or reasonable attorney's fees including, but not limited to, suits or claims for damages for death, human bodily injury or other property resulting from any defects of the GOODS even if the quality of GOODS conforms to the SPECIFICATIONS and has passed the inspection by CLIENT.

## **ARTICLE 22 - LIMITATION OF LIABILITY**

Neither Party shall be liable to the other for any indirect or remote losses of any kind or for damages for loss of anticipated revenue or profits, nor any special, punitive, exemplary or consequential damages, including, but not limited to, loss of goods, cost of capital, cost incurred in connection with labor, overheads, general administrative, transportation, substitute facilities, support sources or other similar damages.

## **ARTICLE 23 - LIENS AND CLAIMS**

CONTRACTOR shall indemnify and hold CLIENT harmless from all liens, claims, assessments, fines and levies created, caused or committed by CONTRACTOR or by its Sub-contractors and all costs, damages and expenses incidental thereto, including without limitation all court and arbitration costs, attorney's fees and other reasonable expenses.

## **ARTICLE 24 - FORCE MAJEURE**

24.1 Neither CONTRACTOR nor CLIENT shall be liable to other Party for any breach of the Terms and Conditions of the CONTRACT where such breach occurs as a result of a Force Majeure.

24.2 The events falling within Force Majeure include but are not limited to Acts of God or force of nature, landslide, lightning, earthquake, flood, fire, explosion, storm or storm warning tidal wave, shipwreck and perils to navigation, act of war (declared or undeclared) or public enemy, strike act (excluding strikes, lockouts or other industrial disputes or action solely amongst employees of CONTRACTOR or its sub-contractor(s)) or omission of sovereign states or those purporting to represent sovereign states, blockade, embargo, quarantine, public disorder, sabotage or similar events beyond the control of the Parties or either of them. Force Majeure shall exclude financial distress on the part of CONTRACTOR or its sub-contractor(s).

Subject to the above, a Party claiming the benefit or protection of this Article, without delay, takes all reasonable steps to remove its inability to comply with the provisions of the CONTRACT.

## **ARTICLE 25 - HEALTH, SAFETY AND ENVIRONMENT ("HSE")**

CONTRACTOR shall be responsible for the HSE of all persons engaged on the performance of CONTRACT and all persons who may be affected by activities of CONTRACTOR and shall comply with all the HSE regulations and procedures.

## **ARTICLE 26 – ASSIGNMENT AND SUBCONTRACT**

CLIENT shall not be liable for any orders other than those issued or confirmed on CONTRACT

or any amendment thereto. CONTRACTOR shall not assign or subcontract any part of the CONTRACT, with the prior written approval of CLIENT.

CONTRACTOR shall procure for CLIENT the right to enter the sub-contractor's premises for the purpose of expediting and inspection.

#### **ARTICLE 27 - VENDOR DATA REQUIREMENTS AND SUBMITTAL**

Drawings and vendor data are to be submitted in strict compliance with the SPECIFICATIONS. If for any reason, the transmission of drawings and vendor data shall be delayed, CLIENT is to be informed immediately in writing, giving reason in for such delay. All drawings and vendor data shall be delivered to CLIENT by hand or through courier service.

All preliminary, intermediate and final drawings and vendor data to be furnished shall be subjected to expediting by CLIENT or its appointed CONTRACTOR.

#### **ARTICLE 28 - EXPEDITING**

28.1 CLIENT or its appointed third party shall have the right to visit CONTRACTOR's mill and plant and those of Sub-contractors for expediting purposes at any time prior to shipment of GOODS. CONTRACTOR and its Sub-contractors shall provide access to their works at all times to CLIENT or its appointed third party. CONTRACTOR's sub-orders must carry a note to this effect.

28.2 Expediting of CONTRACT performance and CONTRACTOR's sub-orders by CLIENT or its appointed third party does not relieve Sub-contractors from their responsibilities to ensure that all sub-orders are delivered to CONTRACTOR's works or plant by the due date.

#### **ARTICLE 29 - INSPECTION**

29.1 CLIENT or its appointed third party shall have the right to inspect, witness tests and survey the quality of GOODS at CONTRACTOR's and its Sub-contractors' plants at any time during manufacturing of GOODS. CONTRACTOR is required to provide every facility for such right to CLIENT or its appointed third party. CONTRACTOR's Sub-orders to its Sub-contractor(s) shall carry a note to this effect. CONTRACTOR's failure to instruct Sub-contractor(s) of the right to CLIENT or its appointed third party to make plant visit for Quality Assurance purposes at any time prior to shipment of GOODS may result in rejection of GOODS manufactured at Sub-contractor(s)' plants.

29.2 CONTRACTOR shall include in all orders to Sub-contractor(s) those SPECIFICATIONS included with the CONTRACTOR, which governs the manufacturing, or testing of GOODS produced by each Sub-contractor(s). Such SPECIFICATIONS, data or other technical description shall be available for review by CLIENT or its appointed third party at the Sub-contractor's facility.

- 29.3 Should any inspected or tested GOODS fail to conform to the SPECIFICATIONS, CLIENT may reject them, and CONTRACTOR shall either replace the rejected GOODS or make all the alternations necessary to comply SPECIFICATIONS requirements free of cost to CLIENT.
- 29.4 CLIENT shall reserve right to inspect, test and, where necessary, reject GOODS after GOODS' arrival in Vietnam and shall in no way be limited or waived by reason of GOODS having previously been inspected, tested and passed by CLIENT or its appointed third party prior to GOODS' shipment from the country of origin.
- 29.5 Nothing in this Article shall in any way release CONTRACTOR from any warranty or other obligations under the CONTRACTOR.

### **ARTICLE 30 - LIQUIDATED DAMAGES**

- 30.1 Should CONTRACTOR fail to deliver GOODS by the time as specified in the Article headed DELIVERY and/or to replace and/or make good the defective GOODS as specified in the Article headed Acceptance of GOODS, CLIEEN shall have the right, at its discretion, to deduct or to be paid by CONTRACTOR, for each day of delay in delivery after the date specified, liquidated damages in the amount of three tenths of one percent (0.3%) of the value of Contract delayed portion in delivery or in replacement or repair up to maximum of eight percent (8%) of the CONTRACT value. CLIEEN reserves the right to terminate this Contract and shall have the right to deduct the liquidated damages from any money due the CONTRACTOR.
- 30.2 The rate of agreed and liquidated damages is not subject to any alteration by Arbitration or any third parties. The amount of agreed and liquidated damages may be deducted by CLIENT from CONTRACTOR's Invoices while effecting the payment. Should CLIENT fail to deduct the sum of money of agreed and liquidated damages from the CONTRACTOR's Invoice, CONTRACTOR shall have to pay it immediately but not later than ten (10) days upon the CLIENT's first written request.

### **ARTICLE 31 - BANK GUARANTEE**

- 31.1 As soon as possible but not later than seven (7) days from the Effective Date of CONTRACT, CONTRACTOR, through a first-class bank acceptable to CLIENT, shall open the Bank Guarantee, in favor of CLIENT, covering ten percent (10%) of CONTRACT PRICE. The validity of the Bank Guarantee shall cover the Warranty Period as stated in Article headed as WARRANTY plus 30 (thirty) days. The Bank Guarantee shall be advised to CLIENT through Vietcombank, Ho Chi Minh City Branch.
- 31.2 The content of the Bank Guarantee shall be in conformity with the Exhibit IV of CONTRACT, which forms an integral part of this Contract.
- 31.3 In the case the Bank Guarantee is not received by CLIENT within fifteen (15) days from the Effective Date of CONTRACT or in the case the Bank Guarantee is not in the same form and

wording as per Exhibit IV of CONTRACT, and CONTRACTOR fails to remedy the requirement within seven (7) days from the receipt of CLIENT's notification, then CLIENT may, at its own discretion, terminate CONTRACT.

31.4 Should CLIENT make use of the Bank Guarantee, CLIENT will inform the CONTRACTOR immediately (but for information purpose only).

31.5 All cost, fees relating to the Bank Guarantee shall be at the CONTRACTOR's account.

#### **ARTICLE 32 - APPLICABLE LAW AND ARBITRATION**

32.1 The CONTRACT and all questions concerning its formation, validity, interpretations and performance shall be governed under the Laws of the S.R. Vietnam.

32.2 Any disputes arising out of or in connection with any CONTRACT which could not settled through negotiation between the two Parties shall be finally settled by the Vietnam International Arbitration Center (VIAC) besides Vietnam Chamber of Commerce and Industry (VCCI) under VIAC Arbitration Rules for final settlement. The place of Arbitration shall be in Ho Chi Minh City, Vietnam. The Arbitral Board shall be three (3) arbitrators and the language of Arbitration shall be English. The costs of Arbitration shall be borne by the lost Party. The award made in accordance with the provisions of this Article shall be final and binding upon two Parties.

#### **ARTICLE 33 - LANGUAGE**

All documents produced by CONTRACTOR in the performance of the CONTRACT as well as all written communications between CLIENT and CONTRACTOR shall be written in the English language which is hereby designated the governing language of the CONTRACT. CONTRACTOR and CLIENT may use any language within their own organizations, except that all Sub-contracts and all written communications pertaining to them shall be in English.

#### **ARTICLE 34 - NON-EXCLUSIVE AGREEMENT**

This CONTRACT is non-exclusive, and CLIENT reserves the right, without having to give any reason whatsoever to engage other suppliers and/or contractors to supply GOODS. CONTRACTOR shall afford such other contractors' adequate opportunity to carry out their contracts and shall supply GOODS in co-operation with those contractors and with CLIENT.

#### **ARTICLE 35 - ENTIRE AGREEMENT**

This CONTRACT constitutes the entire agreement between the Parties hereto and supersedes all prior negotiations, representations or agreements related to this CONTRACT, either written or oral, including CLIENT's bid document and CONTRACTOR's proposal(s) except to the extent they are expressly incorporated into this CONTRACT. No changes, alterations,

or modifications to this CONTRACT shall be effective unless in writing, and executed by the authorized signatories of CLIENT and CONTRACTOR

**SIGNATORIES**

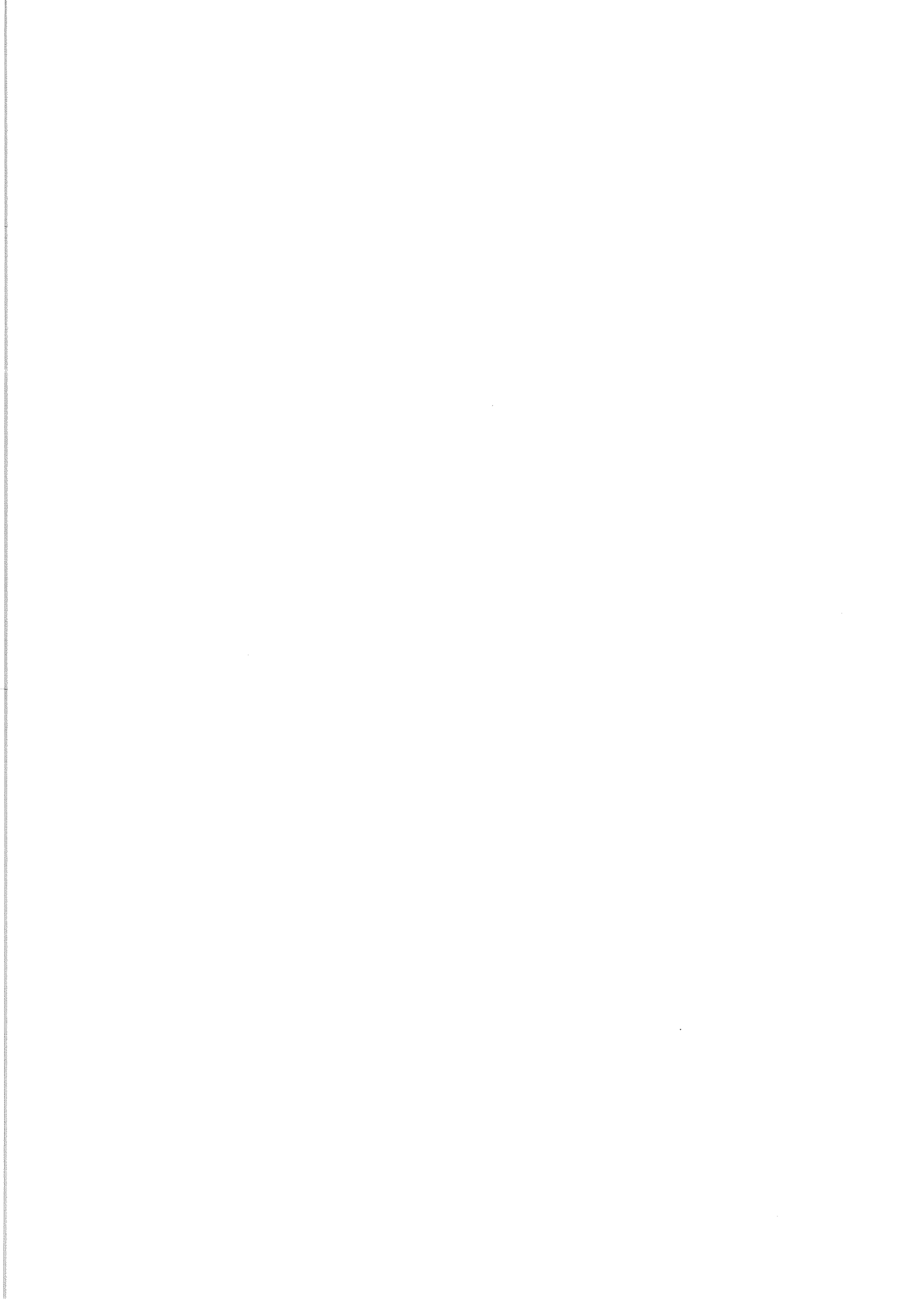
This Contract shall inure to the benefit of and be binding upon the legal representatives, successors and assigns of the Parties hereto.

**IN WITNESS WHEREOF**, the Parties have caused this CONTRACT to be executed in four (04) originals in their respective corporate names by their respective officers, thereunder duly authorised, as of the date and year first above written.

**For and on behalf of**  
**CLIENT**

**For and on behalf of**  
**CONTRACTOR**

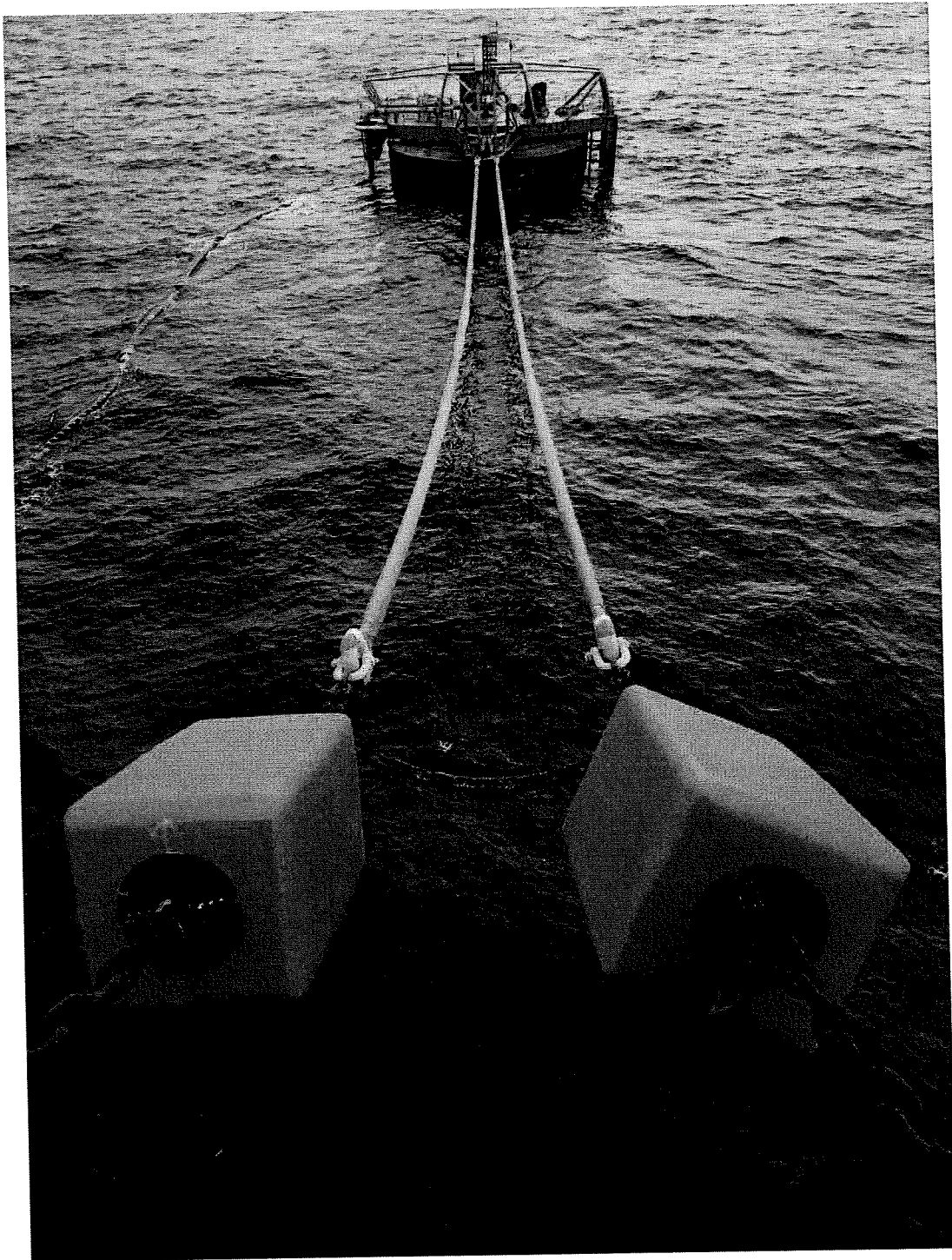




**EXHIBIT I**  
**SCOPE OF SUPPLY AND TECHNICAL REQUIREMENTS**

**I. Introduction**

The mooring hawsers and accessories are to be used for mooring the FSO to CALM bouy.



**II. Working condition**

- ✓ Ambient temperature: 5°C – 50°C
- ✓ Max. Waves significant: Hs: 9.1 m, Tp: 12.2 s
- ✓ Wind max: 10 min: 34 m/s, 1 min: 38 m/s
- ✓ Current surface: 2.28 m/s

*[Handwritten signature]*

III. **Scope of supply:** All equipments should be supply by one supplier only

Item	Description	Unit	Qty
1	CALM buoy mooring hawsers 20" circle	Ea	02
2	H/D Shackle SWL 250T	Ea	02

IV. **SPECIFICATION OF GOODS**

4.1 **CALM buoy mooring hawser (Item 1)**

Mooring hawser is designed and manufactured in accordance with the requirements of Oil Companies International Marine Forum (OCIMF) 2000 edition.

Rope Design

- ✓ Rope size No. 20" (160mm)
- ✓ Rope Material: Nylon (Polyamide)
- ✓ Rope Construction: Grommet end for end spliced in the center each leg.

Rope Performance: Confirmed by form A OCIMF 2000 certified by International Association of Classification Societies (IACS).

- ✓ Minimum New Dry Breaking Strength (NDBS): 6,000 kN
- ✓ **Minimum New Wet Breaking Strength (NWBS): 5,800 kN**
- ✓ Minimum TCLL (Thousand Cycle Load Level): not less than 65%.

Hawser Assembly Description

- ✓ *Assembly Method:* Grommet type
- ✓ *Overall Length:* 65 meters (measured on finished hawser correctly laid on a flat floor and 30 minutes after release of a 4-ton straightening load). Grommet spliced endless with an end for end splice in each grommet leg, at middle of the hawser. The grommet legs seized together with a total of 7 seizing. Hawsers supplied as matched pairs – tolerance on length +/-1%, but tolerance +/- 0.5% between the pair.
- ✓ *Thimble Description:*  
Tubular thimble (Fig. 1) seized one end - Bidder required to submit the drawing of tubular thimble for evaluation

Rope size inch	A mm	B mm	C mm	D mm	E mm	H mm	Weight ~ kg
20"	829	780	374	219	169	219	176

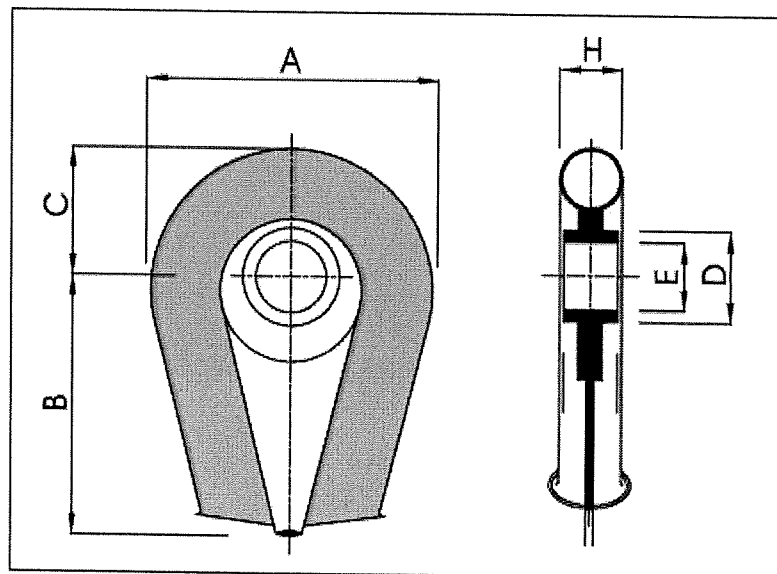
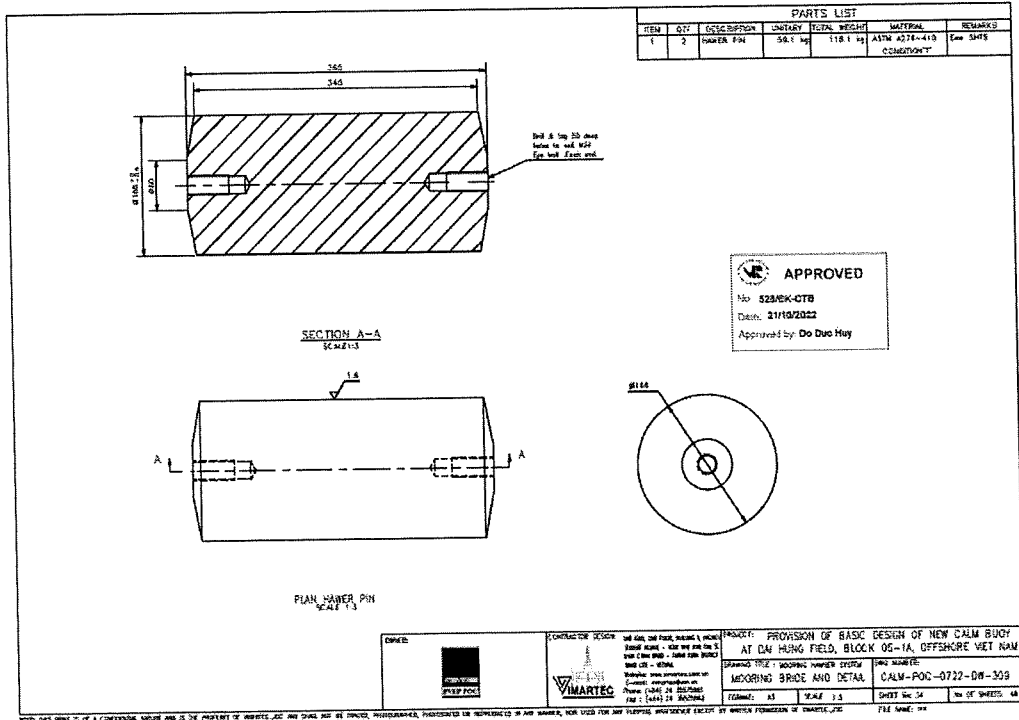
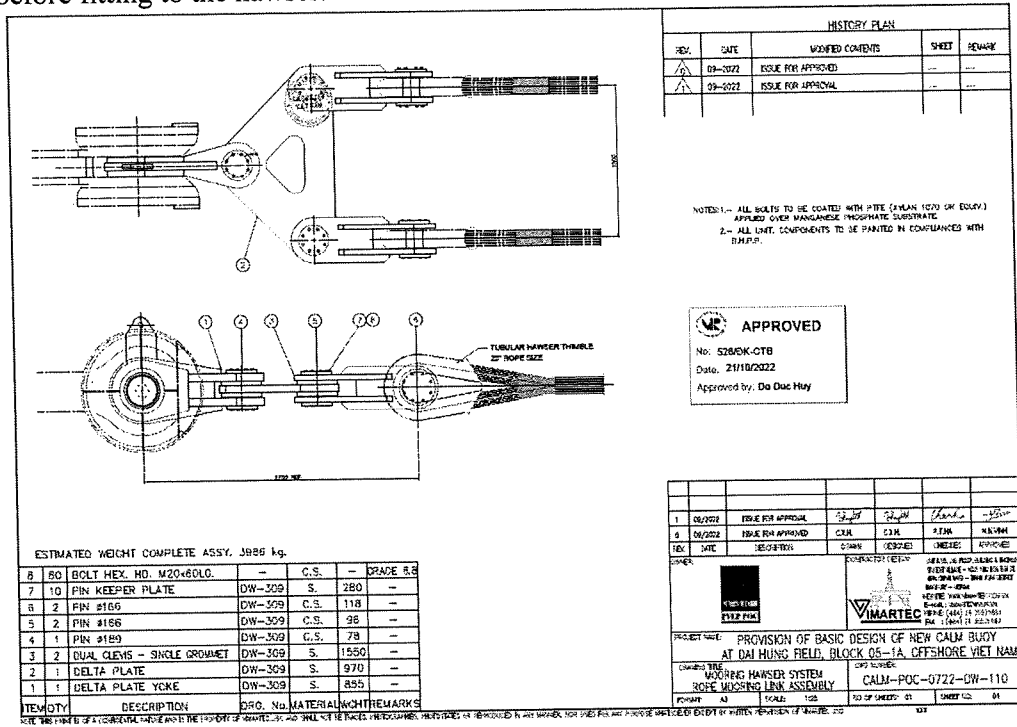


Fig. 1: Tubular thimble

The tubular thimbles will be connected to the dual clevis by the hawser pin(s) Ø166mm as described in the drawings below. Therefore, the tolerance of the hole's diameter (E=169mm) shall be +/- 0%. Bidder is also responsible for checking the dimension of the tubular thimble before fitting to the hawser.



Polyurethane Encapsulated cast galvanized SPM thimble (Fig. 2) the other end - Bidder required to submit the drawing of cast galvanized SPM thimble for evaluation.

*(Handwritten marks)*

Rope size inch	A mm	B mm	C mm	D mm	E mm	F mm	G mm	K mm	X mm	Y mm	Weight kg
20"	940	657	457	348	209	261	880	309	168	177	315

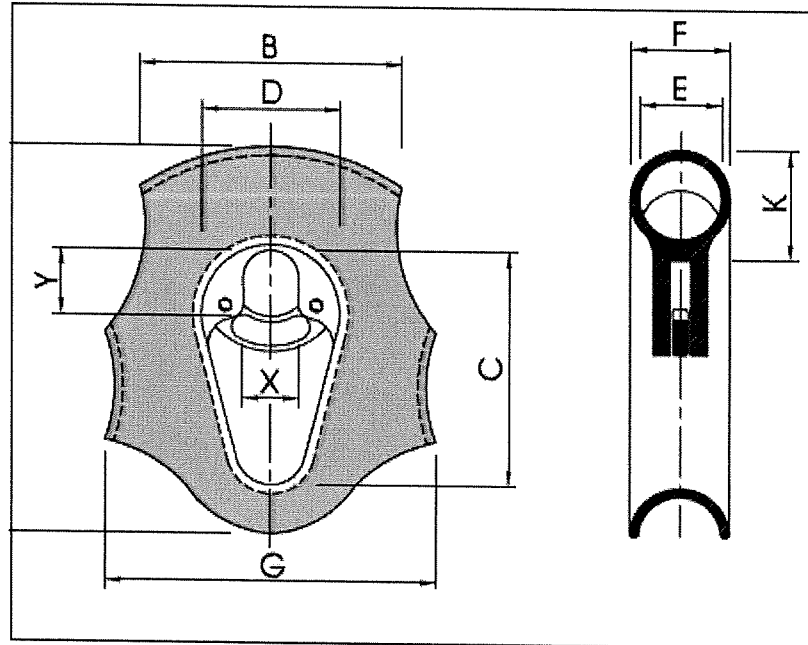
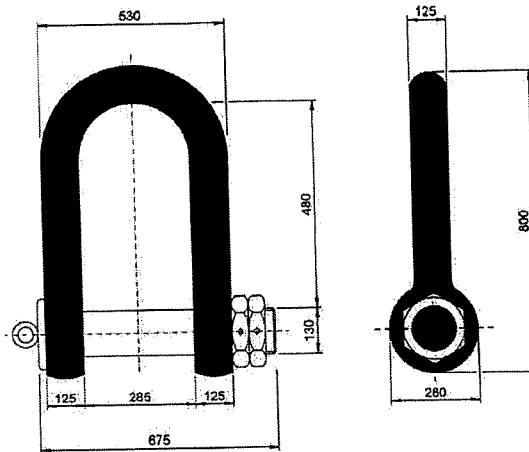


Fig. 2: Thimble for mooring hawser

- ✓ *Chafe protection description:* The entire rope is 100% Polyurethane Elastomer coated. A polyurethane PTC clothe around the rope inside the Tubular thimble and extends from the encapsulation of the SPM thimble end and finish at both ends under the first seizing.
- ✓ *Floatation Description:* The rope is fitted with Integral floatation buoyancy which does not affect mechanical characteristic of hawser.
- ✓ Form A OCIMF 2000 for evaluation.

#### 4.2 H/D Shackle SWL 250T (Item 2)

- ✓ Material: forged high alloy steel quenched and tempered.
- ✓ Finish: galvanized with stainless cotter pins.
- ✓ Dimensions: Body 125mm; Pin 130mm; Jaw gap 285mm; Inside length 480mm; Eye 260mm. Shackle's dimension must be suitable for connecting to SPM thimble of 20" mooring hawser.



Bidder required to submit the drawing for evaluation.

*Bidder is reposable for trial fit the H/D shackle 250 tons to thimbles mentioned in 4.1 to make sure that they are suitable with each others.*

## V. Document and Certificate for Goods

### 5.1 General:

- Certificate of Origin issued by Chamber of Commerce and Industry of Export's Country (original or electronic signed).
- Certificate of Quality issued by Maker (original).
- Warranty certificate for 18 months from date of delivery or 12 months after installation whichever is earlier (original).

### 5.2 Hawsers

- Manufacture's data report including Specification, DWG and catalogue for all components (original or copy – true certify).
- Production/test certificate witness by IACS's member (original).

### 5.3 H/D Shackles

- Material certificate (copy – true certify).
- Manufacturer certificate (original or copy – true certify).
- Proof load certificate (original or copy – true certify).
- MP and Ultra test report (original or copy – true certify).
- Classification inspection certificate (IACS's member) (original or electronic signed)

## VI. Country of origin

EU/G7.

## VII. Manufacture year:

All the goods must be new and unused and manufactured in 2026 or later.

## VIII. Delivery:

Goods should be delivered a.s.a.p. but not latter than 30 weeks from contract signing date.

*[Handwritten signatures]*

## TECHNICAL EVALUATION

The Bids shall be evaluated with the following Essential Criteria:

Item	Evaluation	Criteria	Assessment		
			A	AC	NA
1	Quantity of each item	Major	X		X
2	Technical specification of goods	Major	X		X
3	Tolerance of the hole's diameter of tubular thimble – Bidder confirms	Minor	-/+ 0%	-1% / 0%	Out of this range -1% / 0%
4	Document and Certificate for Goods	Major	X		X
5	Year of production	Major	X		X
6	Country of origin	Major	X		X
7	Delivery time (30 weeks)	Major	X		X

- A** - Technically Acceptable (applied to Major Evaluation Criteria Categories)
- AC** - Technically Acceptable with Concerns (applied to Minor Evaluation Criteria Categories only)
- NA** - Technically Not Acceptable (applied to Major and Minor Evaluation Criteria Categories)
- TA** - Proposals are considered Technical Acceptable if all items are marked with "A" or "AC".
- TNA** - Proposals are considered Technical Not Acceptable if at least one item is marked with "NA".

**EXHIBIT II**  
**CONTRACT PRICE**

This Schedule of Rates & Prices includes design, engineering, procurement of materials, manufacturing & fabrication, assembly, inspection & testing, packing, marking, preservation & transportation, vendor documentation, warranty, and project management for supply of Goods and its ancillaries in compliance with the requirements provided in the Scope of Supply and Technical Requirements in Exhibit I.

Currency: VND/ USD

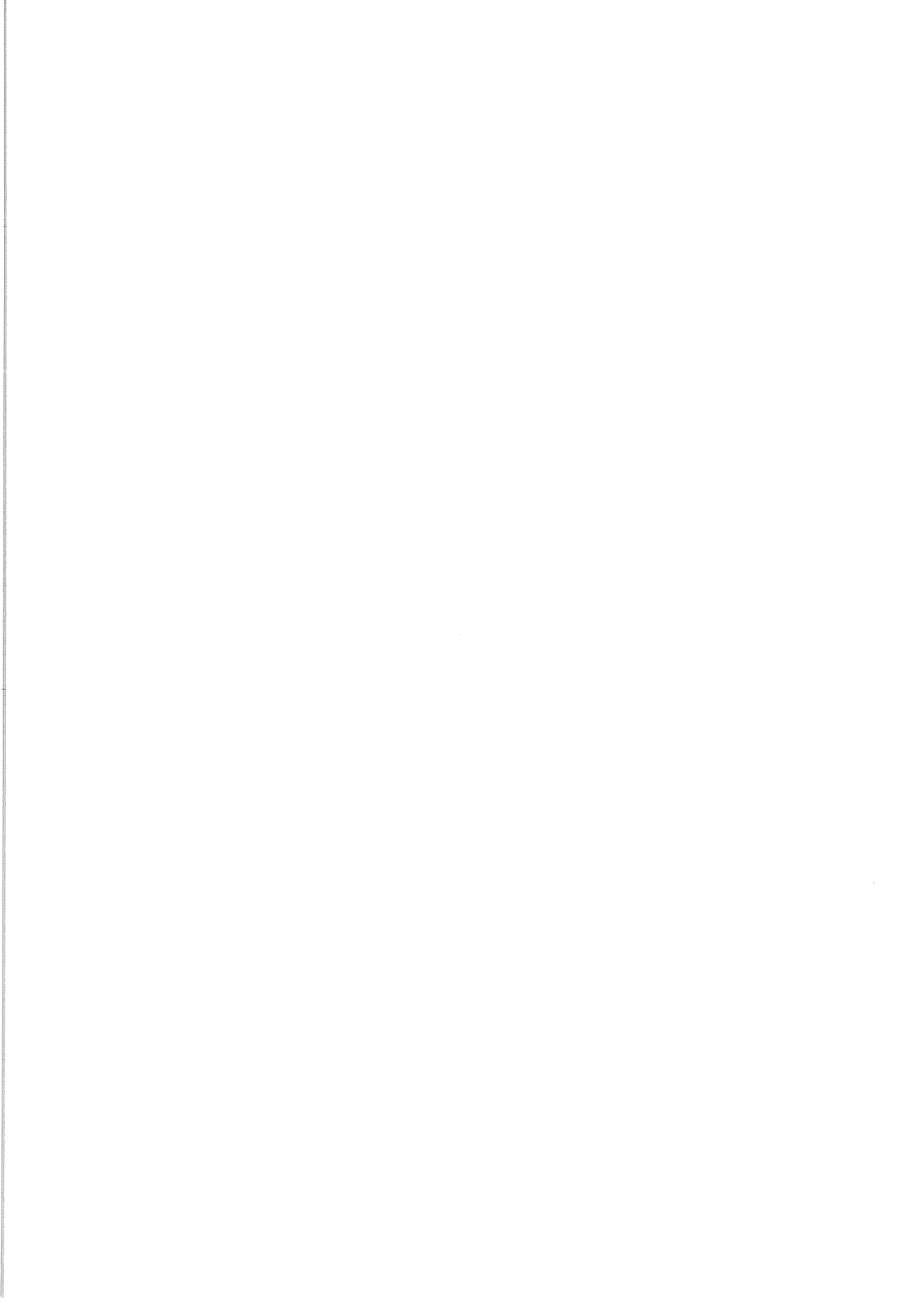
(As attached herewith)

No.	Description	Order Unit	Quantity	Unit Price (VND)	Total Price (VND)
1	.....	....	....		
	Bid Price - DAP/DDP/.... PVEP-POC's warehouse at PTSC port, Rach Dua Ward, Ho Chi Minh City, S.R. VIETNAM (INCOTERM 2020) (Excl.VAT)				
	VAT ...%				
	Total Bid Price				

**Note:**

**The proposed CONTRACT PRICE shall indicate whether it is inclusive of Vietnamese taxes (VAT, CIT, etc.) or not. In the event that the quoted prices do not specify this, they shall be treated as inclusive of all taxes.**

✗ 2



**EXHIBIT III**  
**SHIPPING DOCUMENT, PACKING AND MARKING REQUIREMENT**

*(Will be finalized before Contract award)*

**A. DELIVERY NOTICE AND DOCUMENTS**

Shipment notice shall be sent to the CLIENT by cable or telex or fax as soon as possible, but not later than 15 (fifteen) working days after sending the commodities (B/L date) and contain the following information regarding the shipment:

- a. Contract / Fax number.
- b. Name of commodities, quantities and value.
- c. Number of cases, packages, gross weight, and measurement.
- d. Bill of Lading number, date.
- e. Port of departure, estimated time of departure (ETD), estimated time of arrival (ETA) to Rach Dua Ward, Ho Chi Minh City, S.R.VIETNAM.

The documents required belonging to the GOODS to be delivered on the basis of DAP CLIENT's warehouse, PTSC Downstream Port, Rach Dua Ward, Ho Chi Minh City, S.R. Vietnam - INCOTERMS 2020 shall be as follows:

1. Clean on-board Bill of Lading made out to order of Applicant marked "freight prepaid" (full set).
2. Packing list (full set).
3. C/O by The Chamber of Commerce or Manufacturer's Federation in Manufacturer's/ Exporter's country (01 Original)
4. Certificate of Quality or Certificate of Compliance issued by Manufacturer or Manufacturer's branch in Exporter's country (01 original)
5. Certificate of Guarantee: for 18 months from date of delivery or 12 months after installation whichever is earlier (original).
6. Signed Commercial Invoice with itemized and total prices issued by CONTRACTOR (02 original and 01 copies).

When delivering GOODS at CLIENT's base or warehouse, the Deliverer or Forwarder of CONTRACTOR shall provide CLIENT with the Power of Attorney signed by Legal Representative of CONTRACTOR.

Payment Supporting Documents shall include the above-mentioned items (from item 1 to item 06) and the following documents (01 original):

1. Letter of Payment Request
2. GOOD'S Delivery and Acceptance Protocol

## **B. PACKING**

### **1. General**

- 1.1 This specification outlines the minimum requirements for the packaging and protection of materials and equipment for secure transport to and storage at overseas locations.
- 1.2 The CONTRACTOR may use his own packaging and protection methods only when he considers them equal or superior to those outlined in this specification.

### **2. Responsibilities**

- 2.1 Responsibility for the supply and application of packaging / protection for all transit and storage need rest with the CONTRACTOR named on the Purchase Contract regardless of any subcontractors or suppliers used. This specification in no way limits the CONTRACTOR's responsibility.

If the CONTRACTOR considers it necessary to take further precautions to ensure secure transit and storage CONTRACTOR is obliged to do so.

- 2.2 If the CONTRACTOR named on the Purchase Contract subcontracts part of the order, he must pass this specification and any additional requirements contained in the Purchase Contract on to the subcontractor and so advise the CLIENT.
- 2.3 The CONTRACTOR shall ensure that all material used for packaging / protection complied with applicable laws and regulations of any jurisdiction the package may enter.
- 2.4 The CONTRACTOR shall be debited any costs incurred by the CLIENT due to the CONTRACTOR not having complied with the required SPECIFICATIONS, or any modifications approved by the CLIENT.
- 2.5 Loads that have been roughly treated or damaged in transit to the final destination shall be reinserted to the original purchase specifications at Carrier's expense.  
If the damage was caused by insufficient packaging and/or protection being applied by the CONTRACTOR, then inspection and repair costs may be levied upon the CONTRACTOR.

## **C. MARKING**

- The GOODS shall be packed in sufficiently durable packing material to withstand overseas shipment and tropical conditions and also to ensure against handling at both ends.
- The detailed packing list shall be enclosed in each package to be shipped.
- All packing lists shall be in the English language.
- Port of Destination: PTSC Downstream Port, Vung Tau City, S.R. Vietnam
- Markings shall be as follows:

(i) In case of part, all parts shall be identified legibly by tags or inscription in indelible ink. When metal tags are used, they must be rustproof.

(ii) Consignee and Markings:

Consignee: DOMESTIC PETROLEUM OPERATING BRANCH -  
PETROVIETNAM EXPLORATION PRODUCTION CORPORATION LIMITED  
15<sup>th</sup> Floor, Victory Tower, 12 Tan Trao Str., Tan My Ward, Ho Chi Minh City, S. R.  
VIETNAM

Tel: (84-28) 37762222

Fax: (84-28) 38721079

Contract No.: PVEPPOC-.....

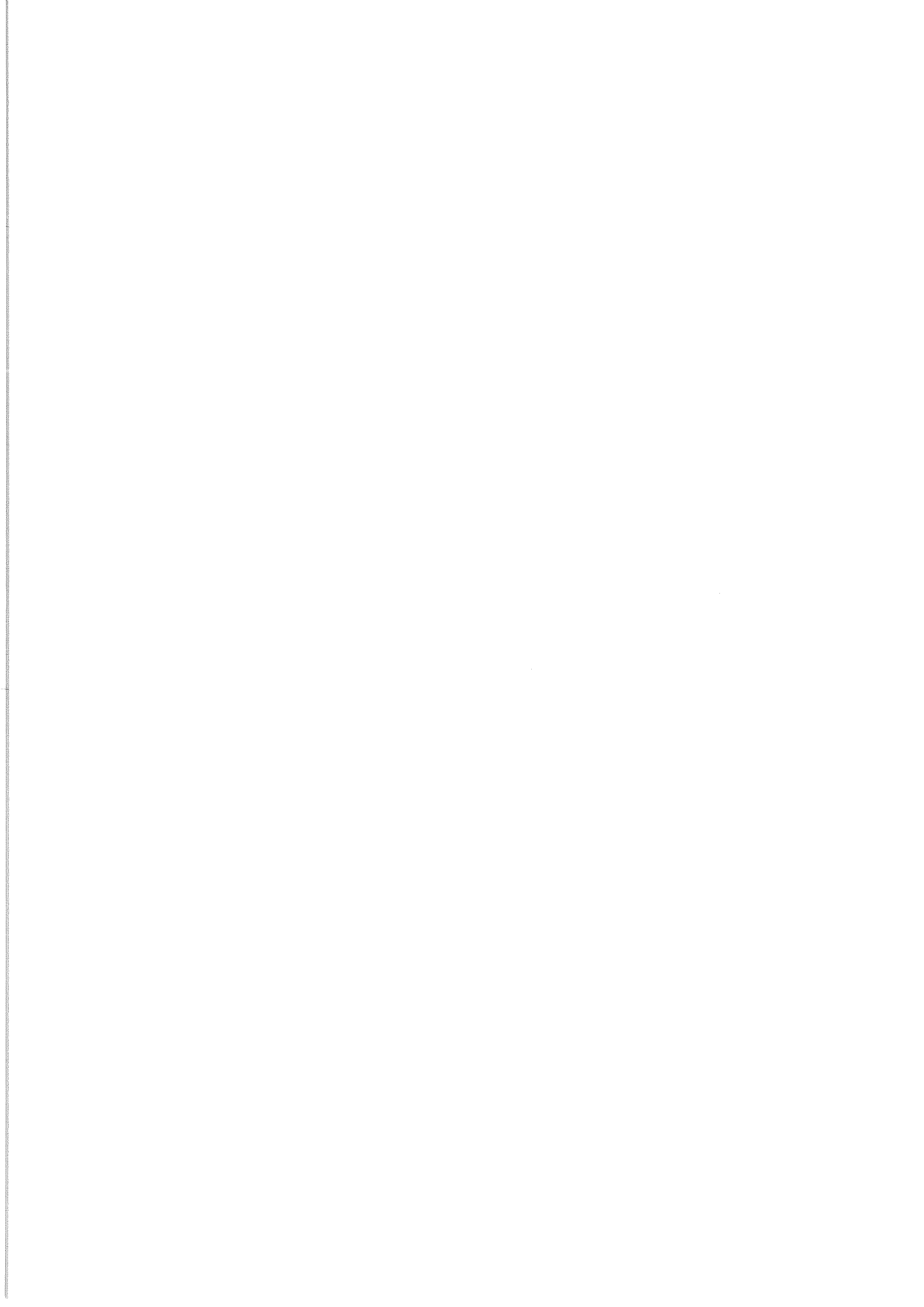
Port of Shipment: .....

Port of Discharge: .....

In addition, each package shall be marked to show:

- (i) Brief description of contents
- (ii) Net Weight of contents
- (iii) Gross Weight of contents
- (iv) Dimensions
- (v) Invoice Number

All packages or containers shall be numbered by the CONTRACTOR to designate the package number and total number of packages being shipped. Other packages in respect of dangerous, inflammable and fragile GOODS and etc. (if applicable) shall in addition to the above, bear marking in accordance with the regulations of the shipping and insurance organization concerned.



**EXHIBIT IV**  
**FORM OF BANK GUARANTEE**  
*Letterhead of Bank*

**BANK GUARANTEE**

TO CONTRACT No. [...] DATED .....

**TO :** PVEP-POC

**ADD:**

Dear Sir,

Issuing date: [.....]

Re: Our **BANK GUARANTEE** No.[....] for USD/ VND [.....]

We have been informed that you (hereinafter called CLIENT) have concluded a Contract No. \_\_\_\_\_(hereinafter called CONTRACT) with (insert the name of the company) (hereinafter called CONTRACTOR) for the Supply of ..... and according to the CONTRACT, CONTRACTOR is required to provide you with a BANK GUARANTEE by a first-class Bank in the amount up to US \$ \_\_\_\_\_ (United States Dollars \_\_\_\_\_) which is ten percent (10%) of the total CONTRACT PRICE.

In consideration of the above, we (name of the Bank), waiving all rights of objection and defense arising from the principal debt, hereby irrevocably and unconditionally undertake to pay immediately to you upon your first written demand stating that CONTRACTOR has failed to fulfill wholly or partly its contractual obligations under the said CONTRACT, any amount or amounts as specified by you up to a total of USD/ VND \_\_\_\_\_ ( United States Dollars/ Vietnam Dong) without the requirement for you to prove or to show grounds or reasons for your demand or the amount specified.

The payment under this BANK GUARANTEE shall be made by us without any deductions for fees and free of any taxes, imports, levies or duties present or future of any nature within \_\_\_\_\_ (*name of the country*).

This BANK GUARANTEE shall be effective from the date of its issuance and shall remain valid sixty (60) days after the completion of CONTRACT duration.

This BANK GUARANTEE is subject to the Uniform Rules for Demand Guarantee of the International Chamber of Commerce (*Publication No. 458*) and shall be governed by and construed in accordance with the Laws of S.R.Vietnam.

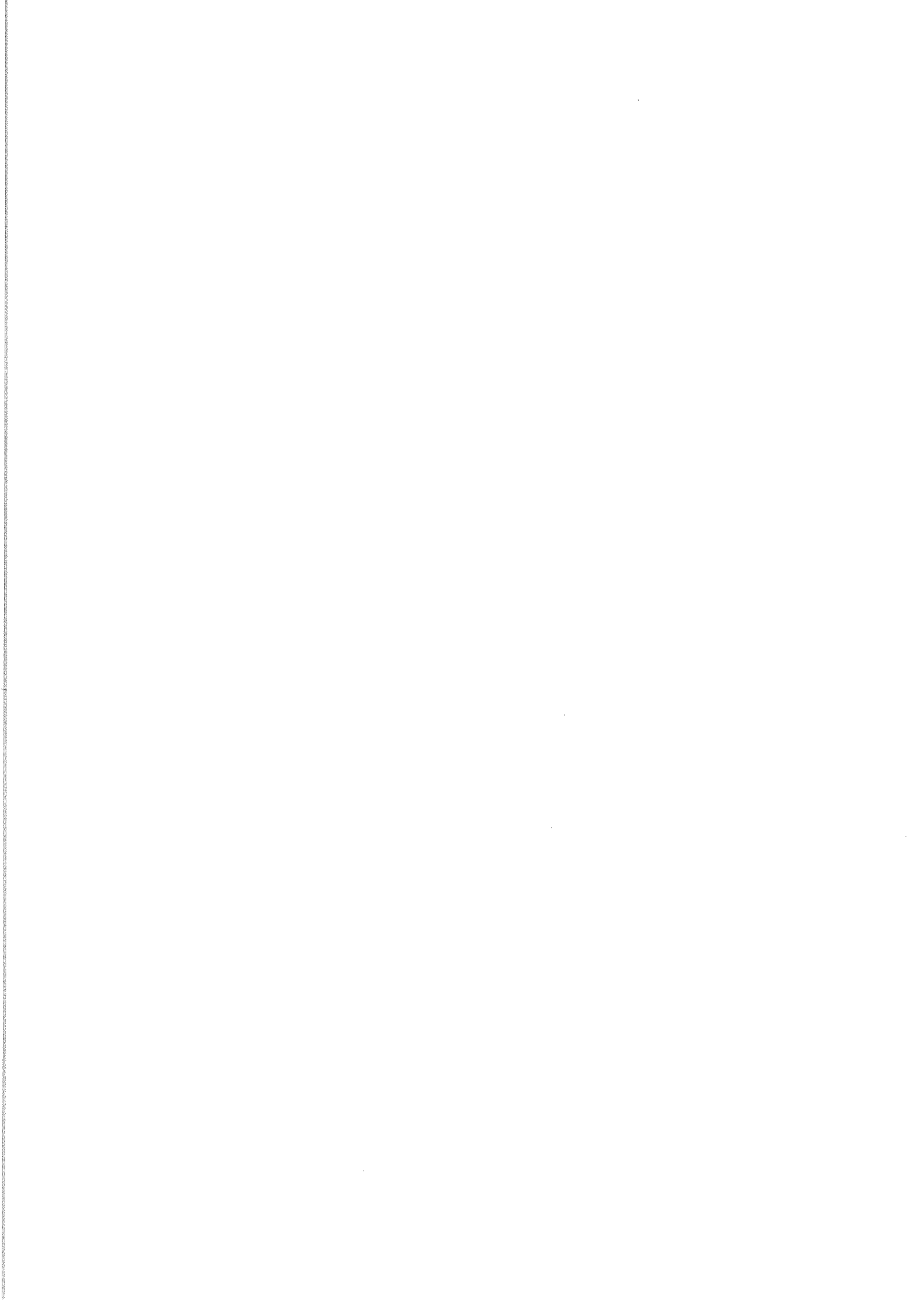
(Name of Bank)

By: \_\_\_\_\_

Title: \_\_\_\_\_

(Authorized signature with stamp of Bank)

*Handwritten initials/signature*



**EXHIBIT V**  
**ACCEPTANCE PROTOCOL**

Place: \_\_\_\_\_, S.R.Vietnam

Date:

The authorized representatives of [...] (hereinafter referred to as CLIENT) of one party, and

The authorized representatives of [...] (hereinafter referred to as the CONTRACTOR) of the other party,

Have made up this Acceptance Protocol to certify that:

On ... [*insert the actual date*] the.... (Hereinafter referred to as the GOODS) have been successfully delivered by the CONTRACTOR in accordance with the CONTRACT No. ... [*insert the Contract number*] and any and all defects and/or discrepancies revealed during hand-over period have been eliminated and/or rectified to the satisfaction of CLIENT.

**GOODS** is in good working condition and ready for normal operation.

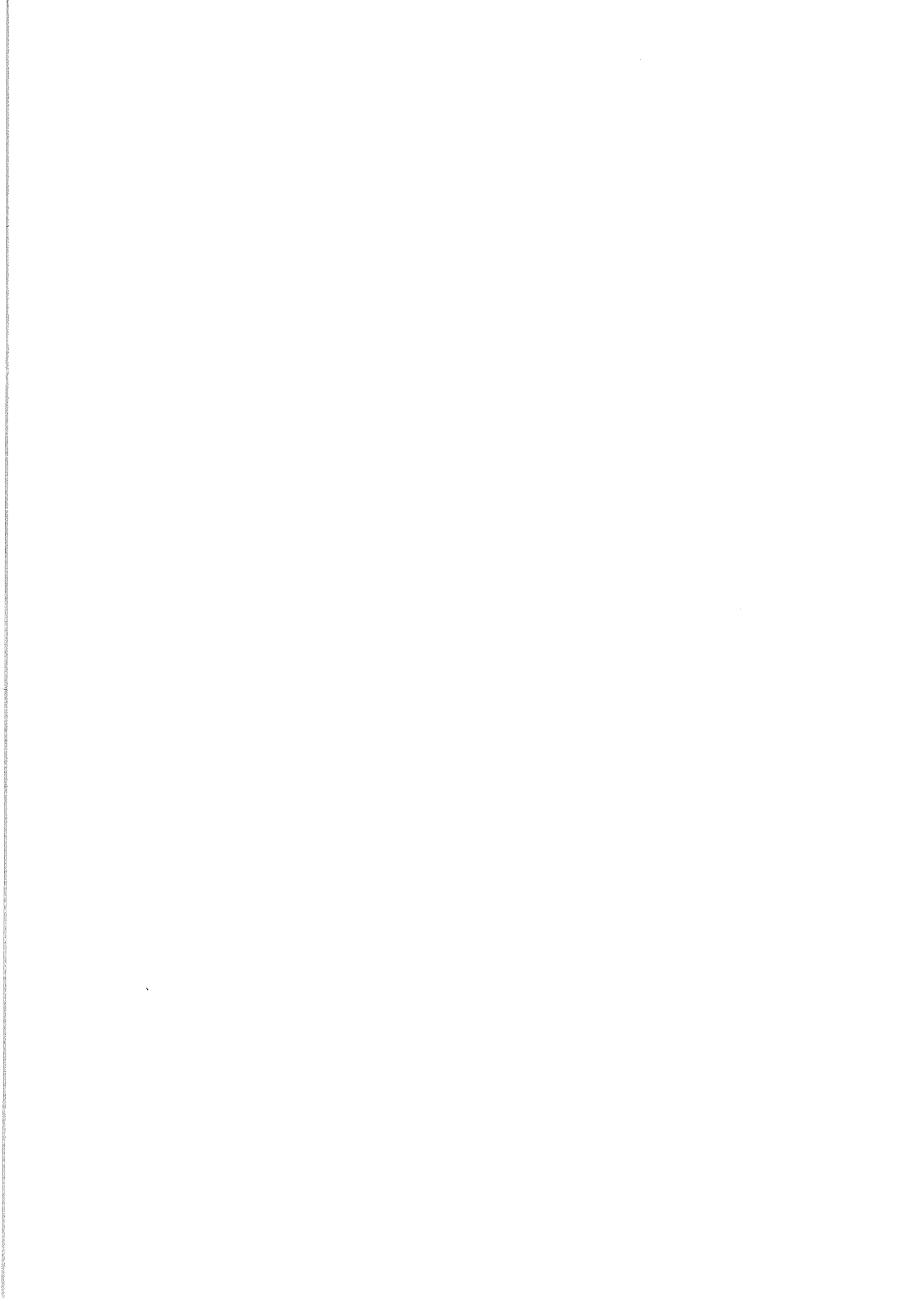
**GOODS' ACTUAL QUANTITY:** .....

However, the signing of this Protocol does not release the CONTRACTOR from his guaranteed obligations and responsibilities as stipulated in the CONTRACT.

**FOR THE CLIENT**

**FOR THE CONTRACTOR**

A 2



**EXHIBIT VI  
CONTRACT CLOSURE CERTIFICATE**

With reference to CONTRACT No. \_\_\_\_\_ dated \_\_\_\_\_ 20\_\_\_\_,

between undersigned CONTRACTOR, \_\_\_\_\_  
( Name of CONTRACTOR )

and \_\_\_\_\_  
( Name of COMPANY )

For Supply of \_\_\_\_\_  
( Title )

In consideration of USD/ VND \_\_\_\_\_ as per final payment under the CONTRACT, the CONTRACTOR hereby unconditionally releases and forever discharges CLIENT and CLIENT premises and property from all claims, liens and obligations of every nature arising out of or in connections with performance of the CONTRACT and all amendments thereto.

The CONTRACT agrees to indemnify and hold CLIENT harmless from and against all cost, losses, damages, claims from any cause of action, judgements and expenses, including legal costs arising out of or in connections with claims against CLIENT which claims arise of the supply of GOODS on the Delivery Time: DD/MM/YYYY under the CONTRACT and which may be asserted by CONTRACTOR or any of its sub-Contractors or any of their representatives, officers, agents or employees.

The foregoing shall not relieve the CONTRACTOR of his obligations under the provision of the CONTRACT, which by their nature survive completion of supplying GOODS including, without limitation, warranties, guarantees and indemnities.

Executed this \_\_\_\_\_ day of \_\_\_\_\_ 20\_\_\_\_\_.

For and on behalf of CLIENT

\_\_\_\_\_  
Signature

\_\_\_\_\_  
Name

For and on behalf of CONTRACTOR

\_\_\_\_\_  
Signature

\_\_\_\_\_  
Name